

9-, 10- and 13-Speed Transmissions

Maintenance Manual 26A



Design Level One
Design Level Two

Service Notes

This Maintenance Manual describes the correct service and repair procedures for the nine-speed, ten-speed and thirteen-speed Design Level One and Design Level Two manual transmissions.

You must follow your company safety procedures when you service or repair equipment. Be sure you understand all the procedures and instructions before you begin work on the unit. Meritor uses the following types of notes to give warning of possible safety problems and to give information that will prevent damage to equipment:

WARNING

A warning indicates procedures that must be followed exactly. Personal injury can occur if the procedure is not followed.

CAUTION

A caution indicates procedures that must be followed exactly. If the procedure is not followed, damage to equipment or components can occur. Personal injury can also occur in addition to damage or malfunctioning of equipment or components.

TORQUE

This symbol is used to indicate fasteners that must be tightened to a specific torque value.

NOTE

A note indicates an operation, procedure or instruction that is important for correct service. A note can also give information that will make service easier and quicker.

Some procedures require the use of special tools for safe and correct service. Failure to use these special tools when required, can cause injury to service personnel or damage to vehicle components.

Silicone Gasket Materials

WARNING

When you apply some silicone gasket materials, small amounts of acid vapor are present. To prevent possible serious personal injury, make sure the work area is well-ventilated. If the silicone gasket material gets into your eyes, flush them with water for 15 minutes. Have your eyes checked by a doctor as soon as possible.

Loctite[®]

WARNING

Take care when using Loctite to avoid serious personal injury. Follow the manufacturer's instructions to prevent irritation to the eyes and skin. If Loctite gets into your eyes, flush them with water for 15 minutes. Have your eyes checked by a doctor as soon as possible.

Cleaning Solvents

WARNING

If you use solvents, hot solution tanks or alkaline solutions incorrectly, serious personal injury can occur. To prevent serious personal injury, follow the instructions supplied by the manufacturer of these products. Do NOT use gasoline to clean parts. Gasoline can explode and cause serious personal injury.

CAUTION

- *Use only solvent cleaners to clean ground or polished metal parts. Hot solution tanks or water and alkaline solutions will damage these parts. You can use isopropyl alcohol, kerosene or diesel fuel for this purpose.*
- *If required, use a sharp knife to remove gasket material from parts. Take care not to damage ground or polished surfaces.*

Table of Contents

SUBJECT	PAGE
Section 1 - General Information	5
Description	5
Identification	6
Nine-Speed Manual Transmissions	6
Ten-Speed Manual Transmissions	6
Thirteen-Speed Manual Transmissions	6
Design Level 1 Manual Transmissions	6
Design Level 2 Manual Transmissions	8
Gear Timing	9
Gasket Sealant	12
Removing Gasket Sealant	12
Installing Gasket Sealant	12
Inspecting Used Parts	15
Repairing or Replacing Parts	19
Cleaning Ground or Polished Parts	19
Cleaning Rough Parts	19
Drying the Cleaned Parts	19
Preventing Corrosion or Rust on Cleaned Parts	19
Section 2 - Lubrication and Maintenance	20
Transmission Oil Specifications	20
Transmissions Oil Coolers	20
Scheduled Maintenance	21
Checking and Adjusting the Oil Level	21
Checking the Condition of the Breather Vent	22
Checking Fastener Torque	22
Inspecting the Transmission for Leaks and Damage	22
Draining and Replacing the Transmission Oil	23
Adjusting Remote Shift Housing Linkage	24
Lubricating the Remote Shift Housing	24
Section 3 - In Vehicle Service	25
Removing the Shift Lever and Tower Assembly	25
Installing the Shift Lever and Tower Assembly	25
Removing the Slave Valve	27
Installing the Slave Valve	27
Removing the Air Filter and Regulator Assembly	28
Installing the Air Filter and Regulator Assembly	29
Removing the Output Yoke and Oil Seal	29
Installing the Oil Seal and Output Yoke	30
Removing and Installing the Remote Control Assembly	33

Table of Contents (Continued)

SUBJECT	PAGE
Section 4 - Removing and Installing the Transmission	34
Removing the Transmission	34
Installing the Transmission	36
Section 5 - Overhauling the Shift Lever and Tower Assembly	41
Disassembling the Aluminum Tower Assembly	41
Assembling the Aluminum Tower Assembly	43
Disassembling the Cast Iron Tower Assembly	46
Assembling the Cast Iron Tower Assembly	47
Section 6 - Remote Control Assembly	48
Disassembling the Remote Control Assembly	48
Assembling the Remote Control Assembly	49
Section 7 - Removing and Installing the Top Cover Assembly	50
Removing the Top Cover Assembly	50
Installing the Top Cover Assembly	52
Section 8 - Overhauling the Top Cover Assembly	54
Disassembling the Standard and Forward Position Top Cover Assembly	54
Assembling the Standard and Forward Position Top Cover Assembly	60
Disassembling the Standard and Forward Position "X" Bar Top Cover Assembly	66
Assembling the Standard and Forward Position "X" Bar Top Cover Assembly	72
Section 9 - Removing and Installing the Input Shaft.....	79
Removing the Input Shaft	79
Installing the Input Shaft	81
Section 10 - Removing and Installing the Clutch Housing	83
Removing the Clutch Housing	83
Installing the Clutch Housing	83
Section 11 - Removing and Installing the Auxiliary Case.....	85
Removing the Auxiliary Case-Nine-Speed and Ten-Speed Transmissions	85
Installing the Auxiliary Case-Nine-Speed and Ten-Speed Transmissions	90
Removing the Auxiliary Case-Thirteen-Speed Transmissions	94
Installing the Auxiliary Case-Thirteen-Speed Transmissions	98
Removing the Auxiliary Drive Gear	102
Installing the Auxiliary Drive Gear	103
Section 12 - Overhauling the Main Case	104
Removing the Mainshaft	104
Removing the Input Shaft	110
Removing the Main Countershafts	113

Table of Contents (Continued)

SUBJECT	PAGE
Section 12 - Overhauling the Main Case(Continued)	104
Removing the Reverse Idler Gear Assembly	114
Removing the Oil Pump	115
Removing the Magnets	116
Removing the PTO Covers	116
Installing the PTO Covers	117
Installing the Magnets	117
Installing the Oil Pump	118
Installing the Reverse Idler Gear Assemblies	118
Installing the Input Shaft	119
Installing the Main Countershafts	123
Installing the Mainshaft	125
Section 13 - Overhauling the Auxiliary Drive Gear	134
Disassembling the Auxiliary Drive Gear Assembly	134
Assembling the Auxiliary Drive Gear Assembly	136
Section 14 - Overhauling the Mainshaft	137
Disassembling the Mainshaft	137
Assembling the Mainshaft	139
Section 15 - Overhauling the Main Countershafts	150
Disassembling the Main Countershaft	150
Assembling the Main Countershaft	152
Section 16 - Overhauling the Auxiliary Case	155
Disassembling the Auxiliary Case-Nine-Speed and Ten-Speed Transmissions	155
Assembling the Auxiliary Case-Nine-Speed and Ten-Speed Transmissions	163
Disassembling the Auxiliary Case-Thirteen-Speed Transmissions	174
Assembling the Auxiliary Case-Thirteen-Speed Transmissions	182
Section 17 - Main Countershaft End Play Adjustment	193
Checking and Adjusting the End Play of the Main Countershafts	193
Section 18 - Auxiliary Countershaft End Play Adjustment	200
Checking and Adjusting the End Play of the Auxiliary Countershafts	200
Section 19 - Troubleshooting	207
General Information	207
Troubleshooting Other Systems	208
Troubleshooting Leaks	209
Troubleshooting Vibrations	209
Troubleshooting Noises	210
Troubleshooting Operating Conditions	211

Table of Contents (Continued)

SUBJECT	PAGE
Section 20 - Specifications	214
Transmissions Oil Capacities	214
Transmission Oil Specifications	214
Fastener Torque Locations-Nine-Speed and Ten-Speed Transmissions	215
Fastener Torque Chart-Nine-Speed and Ten-Speed Transmissions	218
Fastener Torque Locations-Thirteen-Speed Transmissions	220
Fastener Torque Chart-Thirteen-Speed Transmissions	223
Air Line Locations-Nine-Speed and Ten-Speed Transmissions	225
Air Line Identification Chart-Nine-Speed and Ten-Speed Transmissions	226
Air Line Locations-Thirteen-Speed Transmissions	227
Air Line Identification Chart-Thirteen-Speed Transmissions	228
Holding Cover Template	229
Special Tools	230

Description

See Figure 1-1.

This publication describes the service procedures for the following Meritor transmissions:

- Nine-Speed Transmissions.
- Ten-Speed Transmissions.
- Thirteen-Speed Transmissions.

Two design levels are described in this publication:

- **Design Level One.** This applies to transmissions with serial numbers LB93001999 and below. Snap rings are used to keep the tapered roller bearings in the case.
- **Design Level Two.** This applies to transmissions with serial numbers LB93002000 and above. Retainer plates are used to keep the tapered roller bearings in the case.

The main case, which includes the mainshaft, the main countershafts, the input shaft, the reverse idler gear and the (optional) oil pump, are the same for all transmissions.

The auxiliary case is the same design for nine-speed and ten-speed transmissions while the auxiliary case for the thirteen-speed transmission is different. The thirteen-speed transmission uses a different case, piston housing and output shaft assembly. The thirteen-speed transmission also uses a splitter gear set in addition to a **HI** and **LO** range gear set.

The input torque from the engine is distributed by two countershafts and one mainshaft. An auxiliary case provides the **LO** and **HI** ranges of operation.

Tapered roller bearings are used to support the countershafts in the main transmission case and the auxiliary section.

Figure 1-1

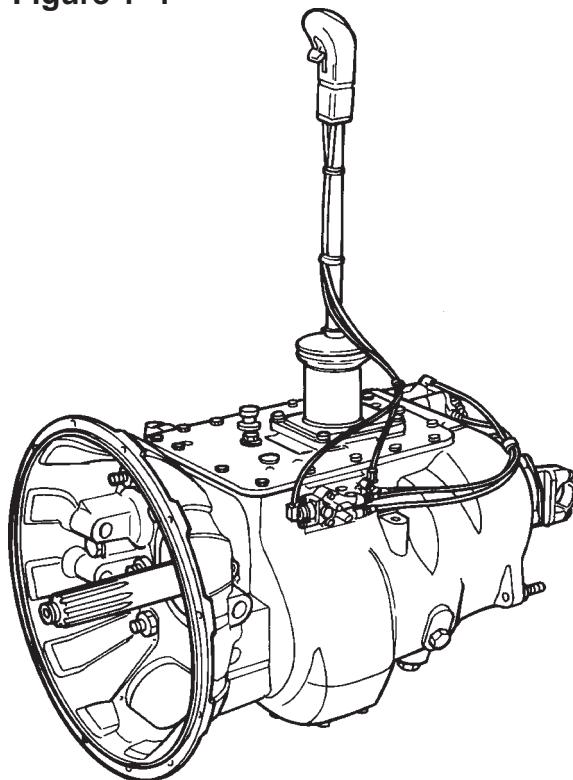

NINE-SPEED TRANSMISSION
TEN-SPEED TRANSMISSION

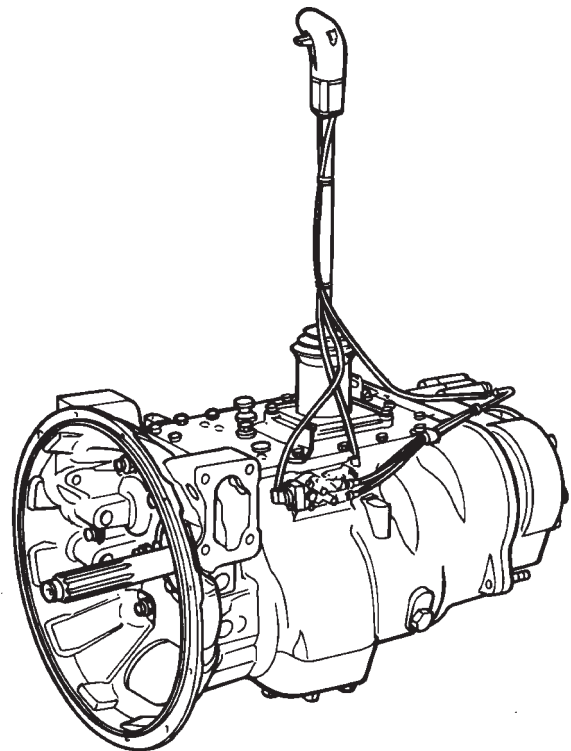

THIRTEEN-SPEED TRANSMISSIONS

Section 1

General Information

An air shift system is used to select the **LO** or **HI** range of operation on all transmissions and the **DIR** and **OD** “splitter” range of operation on thirteen-speed transmissions. For more information, see Maintenance Manual Number 26B, Nine Speed Manual Transmissions Air Shift Systems or Maintenance Manual 26D, Thirteen-Speed Transmissions Air Shift Systems.

Identification

An identification plate is installed on the side of the transmission. Use the information on the identification plate when ordering parts. **Figure 1–2.**

See **Figure 1–2** for an explanation of the model identification number and the identification plate.

Nine–Speed Manual Transmissions

The transmission is identified by the number “9” in the Speed portion of the model number. **Figure 1–2.**

The transmission uses nine forward gears (five gears in the **LO** range and four gears in the **HI** range) and two reverse gears.

The transmission may be either a “Design Level 1” or a “Design Level 2”. See the explanation in this section.

Ten–Speed Manual Transmissions

The transmission is identified by the number “10” in the Speed portion of the model number. **Figure 1–2.**

The transmission uses ten forward gears (five gears in the **LO** range and five gears in the **HI** range) and two reverse gears.

The transmission is a “Design Level 2”. See the explanation in this section.

Thirteen–Speed Manual Transmissions

The transmission is identified by the number “13” in the Speed portion of the model number. **Figure 1–2.**

The transmission uses thirteen forward gears (five gears in the **LO** range and eight gears in the **HI** range that are divided between four **DIR** gears and four **O/D** gears) and two reverse gears.

The transmission may be either a “Design Level 1” or a “Design Level 2”.

The auxiliary case is different from the nine-speed and the ten-speed transmissions.

Design Level 1 Manual Transmissions

Design Level 1 Manual Transmissions apply to transmissions with serial numbers below LB93002000.

The transmission is identified by the number “1” in the Design Level portion of the model number. **Figure 1–2.**

Section 1 General Information

Figure 1-2

RMX10-145A2S002

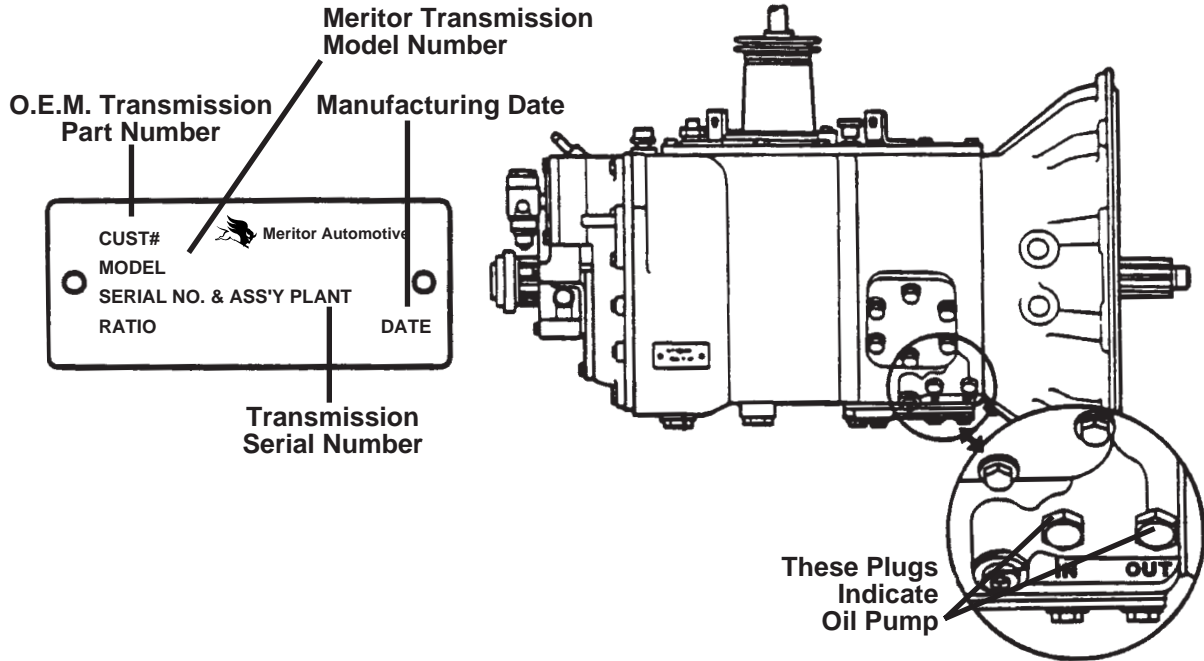

R M X 10-145 A 2 S 002

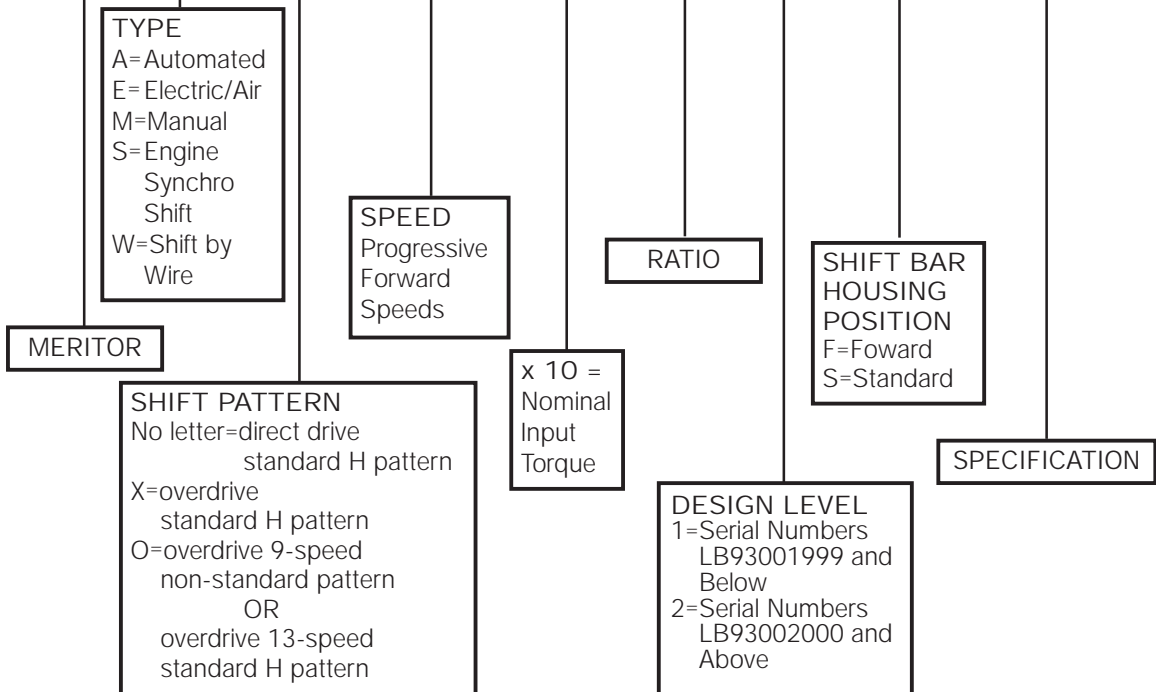

Section 1

General Information

Snap rings are used to retain the bearing cups for the main countershaft in the main case and for the auxiliary countershafts in the auxiliary case and the main case.

Selective snap rings are used to adjust the end play in the main case and the auxiliary case.

Design Level 2 Manual Transmissions

Design Level 2 Nine-Speed, Ten-speed and Thirteen-Speed Manual Transmissions apply to all transmissions with serial numbers LB93002000 and above.

The transmission is identified by the number “2” in the Design Level portion of the model number. **Figure 1–2.**

Retainer plates are used to retain the bearing cups for the main countershaft in the main case. The bearing cover and the selective washer are used to retain the cups for the auxiliary countershaft in the auxiliary case.

Selective shims are used to adjust the end play in the main case. Selective washers are used to adjust the end play in the auxiliary case.

Gear Timing

If the timing marks on the gears are not aligned in the main case or in the auxiliary case, the transmission will not operate.

The timing marks must be correctly aligned when the transmission is serviced.

The timing marks will not go out of alignment during normal vehicle operation unless the gear teeth are damaged.

Timing Marks in Auxiliary Case

NOTE:

To make sure the timing marks are in the correct locations, count the number of gear teeth, divide the total teeth number by "2" and put the mark in the correct location.

1. Put timing marks on the auxiliary low gear. Mark one tooth with paint. Mark a second tooth opposite (180°) the first timing mark. **Figure 1-3.**
2. Use paint to put timing marks on two

teeth next to each other on each countershaft low gear of the auxiliary countershafts. Make sure the marks are aligned with the "O" stamping on the countershaft. **Figure 1-3.**

3. During assembly, each of the two timing marks on the auxiliary low gear must be between the two marked teeth on each countershaft low gear. **Figure 1-4.**

All the timing marks must be aligned if the transmission is to operate correctly.

If the timing marks are not painted in the correct position on the gears, only one set of marks will be aligned.

4. To check the alignment of the timing marks, rotate the output shaft seven (7) complete revolutions. All the gears must rotate.
5. For complete service procedures, see 'Assembling the Auxiliary Case' in Section 16, "Overhauling the Auxiliary Case".

Figure 1-3

**AUXILIARY LOW GEAR-
MARK ONE TOOTH ON
EACH SIDE 180° APART**

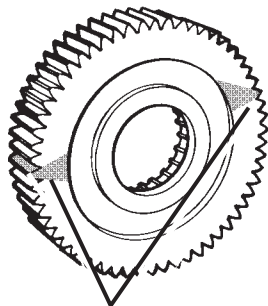

TIMING MARKS

**COUNTERSHAFT LOW GEAR-MARK
TWO TEETH OVER "O" STAMPING**

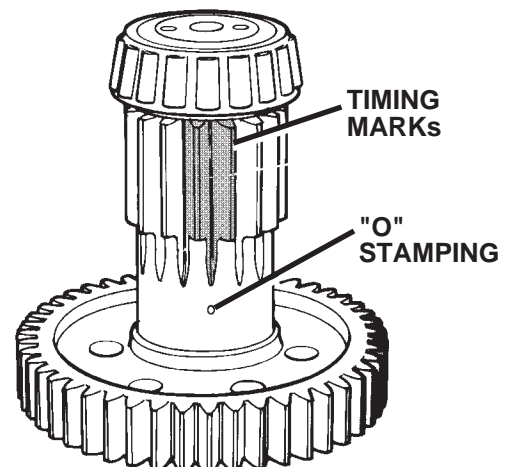

**TIMING
MARKS**

**"O"
STAMPING**

Section 1

General Information

Figure 1-4

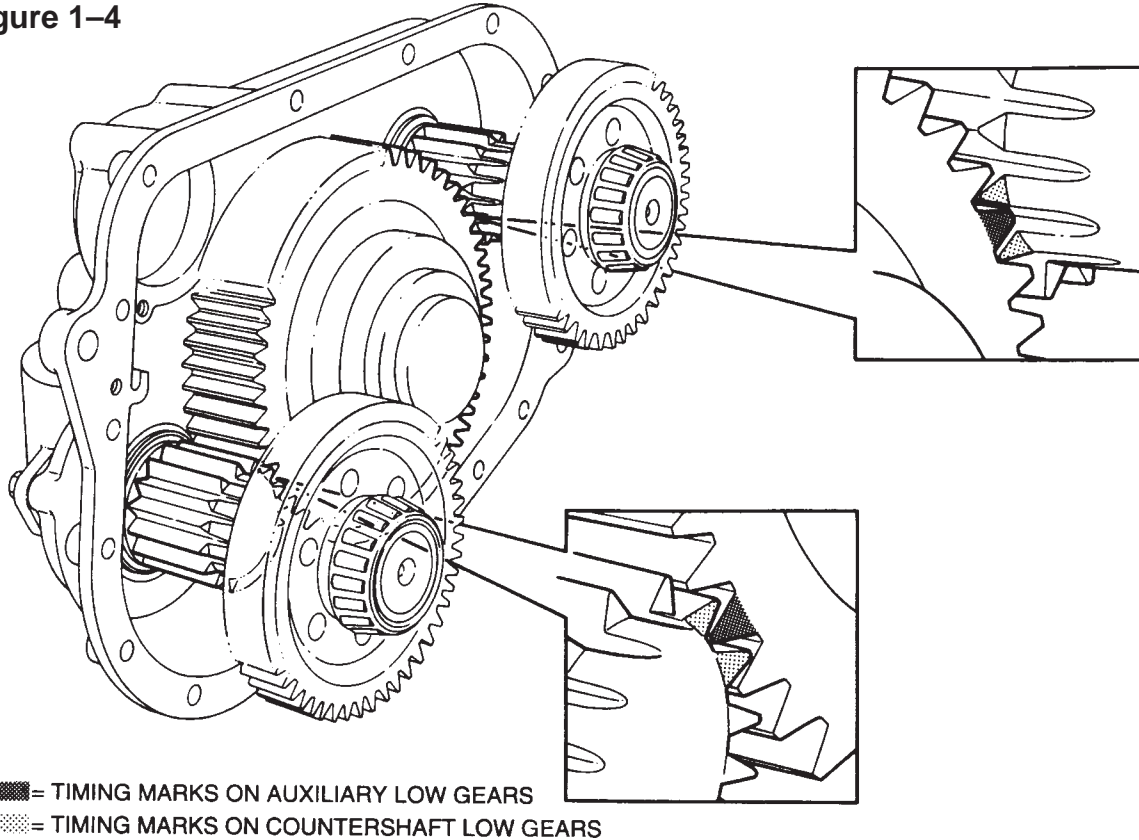

Timing Marks in Transmission Case

NOTE:

To make sure the timing marks are in the correct locations, count the number of gear teeth, divide the total teeth number by “2” and put the mark in the correct location.

1. Put timing marks on the main drive gear on the input shaft. Mark one tooth with paint. Mark a second tooth opposite (180°) the first timing mark. **Figure 1-5.**
2. Use paint to put timing marks on two teeth next to each other on each driven gear of the main countershafts. Make sure the marks are aligned with the slot for the key or the “O” stamping on the countershaft. **Figure 1-5.**
3. During assembly, each of the two timing marks on the main drive gear

must be between the two marked teeth on each countershaft drive gear.

Figure 1-6

All the timing marks must be aligned if the transmission is to operate correctly.

If the timing marks are not painted in the correct position on the gears, only one set of marks will be aligned.

NOTE:

The main shaft and the auxiliary drive gear must be installed when the alignment marks in the transmission case are checked.

4. To check the alignment of the timing marks, rotate the input shaft. All the gears must rotate.
5. For complete service procedures, see ‘Assembling the Transmission Case’ in Section 12, “Overhauling the Main Case”.

Section 1

General Information

Figure 1-5

MAINDRIVE GEAR
—MARK ONE TOOTH
ON EACH SIDE
180° APART

COUNTERSHAFT DRIVEN GEAR
—MARK TWO TEETH OVER
THE SLOT FOR THE KEY
OR THE "O" STAMPING

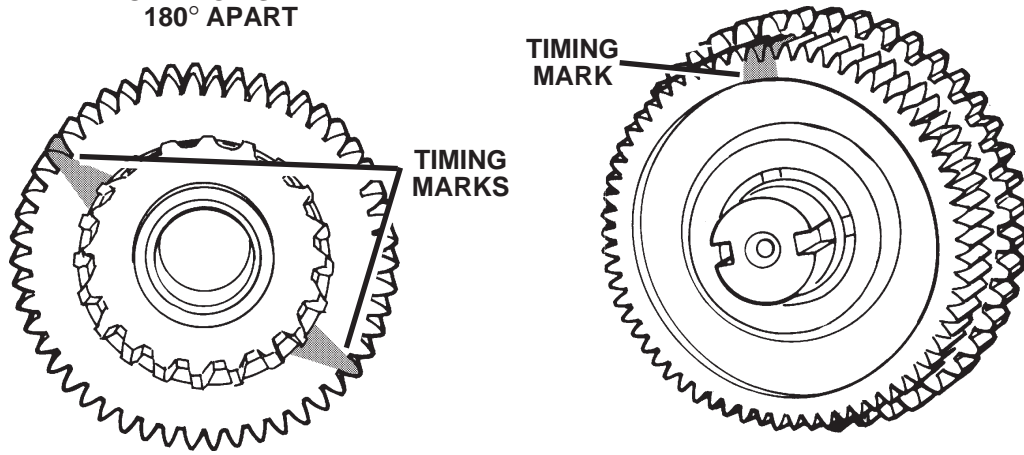
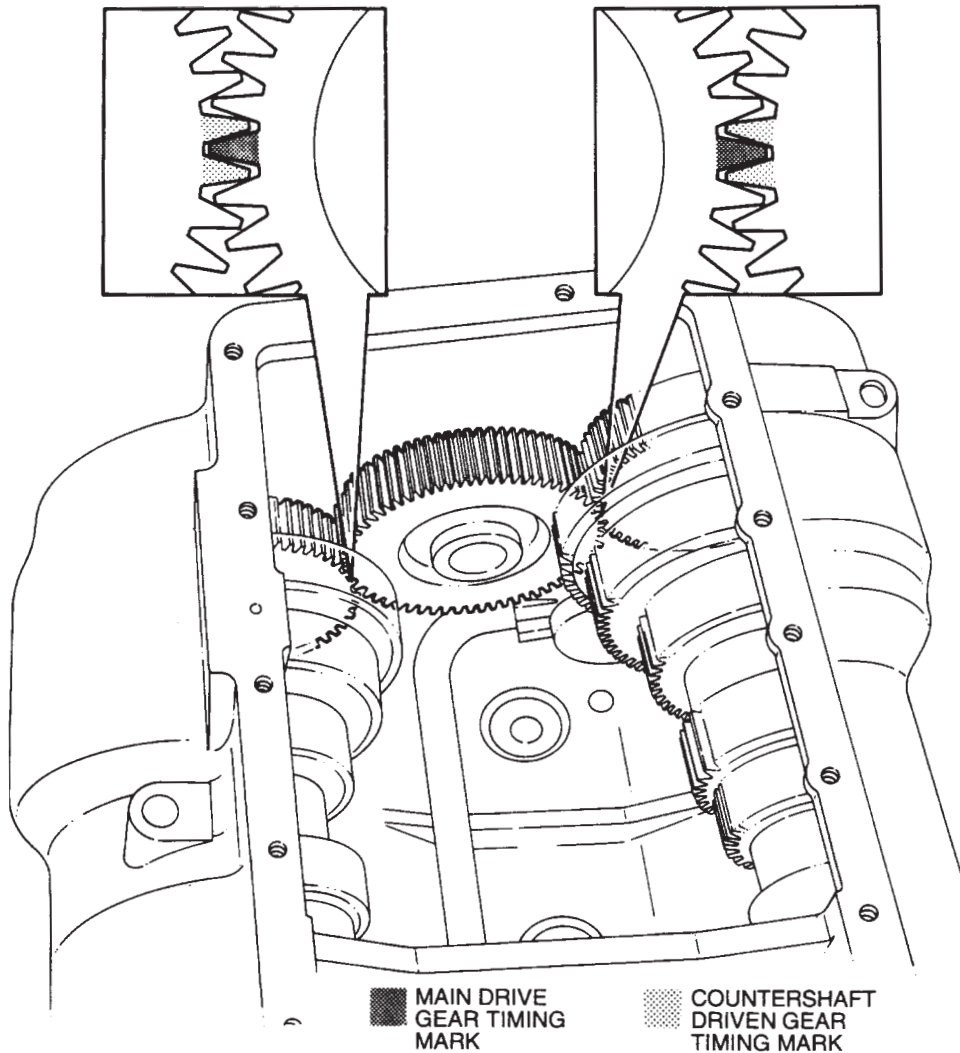

Figure 1-6



Section 1

General Information

Gasket Sealant

The transmission uses Loctite® RTV Sealant™ #5699 (Meritor Part Number 2297-A-7021) between the following components.

NOTE:

See Figures 1–9 to 1–11 for sealant patterns.

- Clutch housing and main case.
- PTO covers and main case.
- Top cover and main case.
- Auxiliary case and main case.
- Auxiliary countershaft covers and auxiliary case.
- Output bearing retainer on the auxiliary case.
- Input bearing retainer on the main case.
- Range piston housing to the auxiliary case.

CAUTION

Use Loctite® RTV Sealant™ #5699 (Meritor Part Number 2297-A-7021) as a gasket. The use of any other gasket material (such as a corrosive sealant) can cause leaks and damage the transmission.

Removing the Sealant

See Figure 1–7.

1. Remove the component as described in the correct section of this manual.
2. Use a scraper to remove all sealant material from the surface.

Installing the Sealant

See Figure 1–8.

1. Clean the mounting surfaces with a chlorinated solvent such as Loctite® Safety Solvent or equivalent.

CAUTION

Apply the sealant in a 1/8 inch (2 mm) bead. If too much sealant is used, the sealant that extends over the edges can break off and plug the oil passages.

2. Apply Loctite® RTV Sealant™ #5699 (Meritor Part Number 2297-A-7021) with a sealant dispenser to one surface. Apply the sealant in a continuous pattern with a 1/8 inch (2 mm) bead. Make sure the bead encircles any fastener holes.
3. Install the component as described in the correct section of this manual.

Figure 1–7

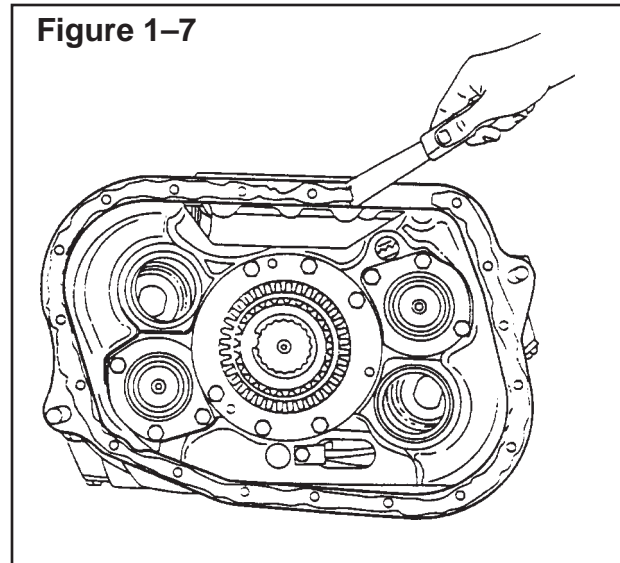
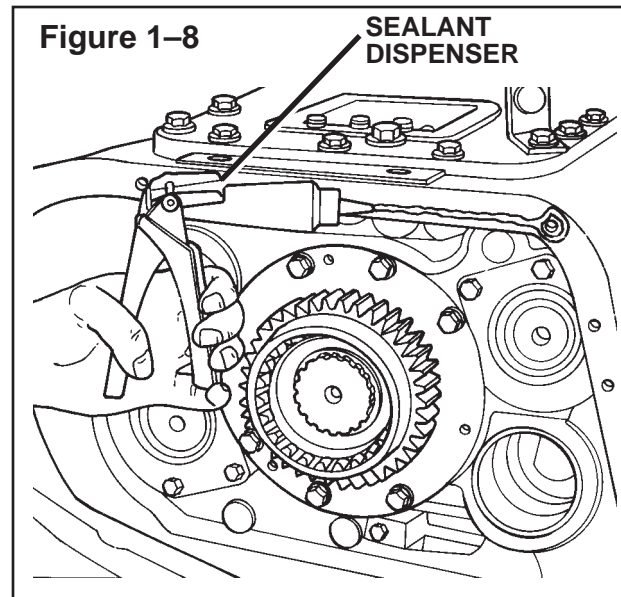

Figure 1–8



Section 1

General Information

Figure 1-9 AUXILIARY COVER-TO-TRANSMISSION CASE GASKET PATTERN

• PUT THE PATTERN ON THE AUXILIARY COVER

TRANSMISSION CASE GASKET PATTERN

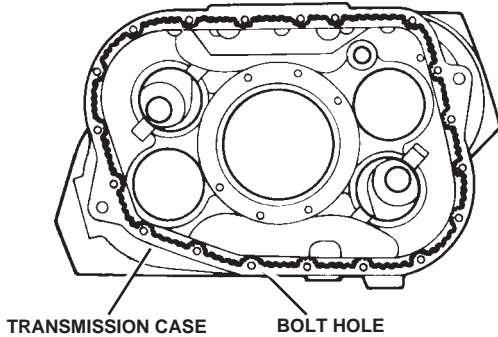

AUXILIARY COVER GASKET PATTERN

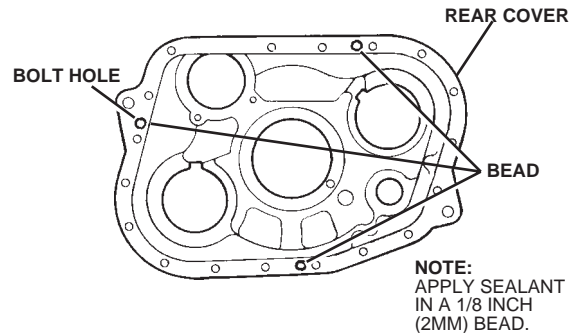

CLUTCH HOUSING-TO-TRANSMISSION CASE GASKET PATTERN

• PUT THE PATTERN ON THE TRANSMISSION CASE

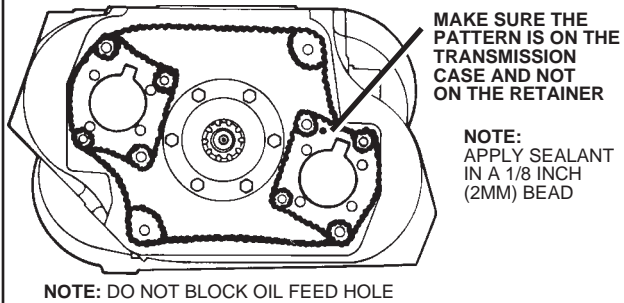

PTO COVERS-TO-TRANSMISSION CASE GASKET PATTERN

• PUT THE PATTERN ON THE TRANSMISSION CASE

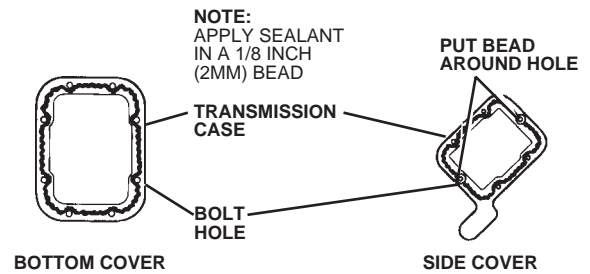

SHIFT BAR HOUSING-TO-TRANSMISSION CASE GASKET PATTERN

• PUT THE PATTERN ON THE TRANSMISSION CASE

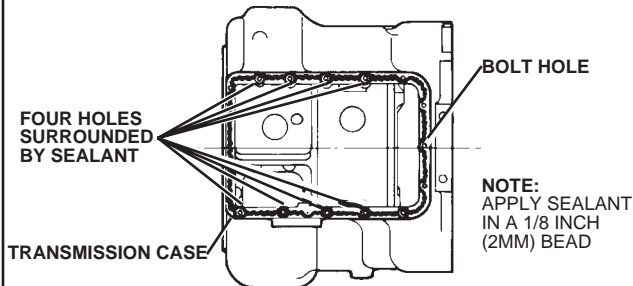

OUTPUT BEARING RETAINER-TO-AUXILIARY COVER GASKET PATTERN

• PUT THE PATTERN ON THE OUTPUT BEARING RETAINER

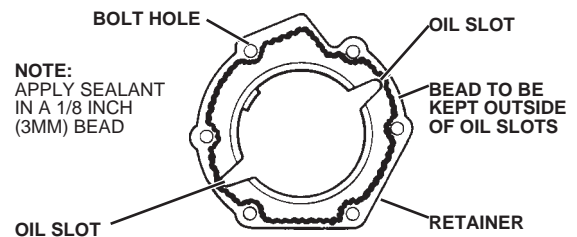

INPUT BEARING RETAINER-TO-TRANSMISSION CASE GASKET PATTERN

• PUT THE PATTERN ON THE INPUT BEARING RETAINER

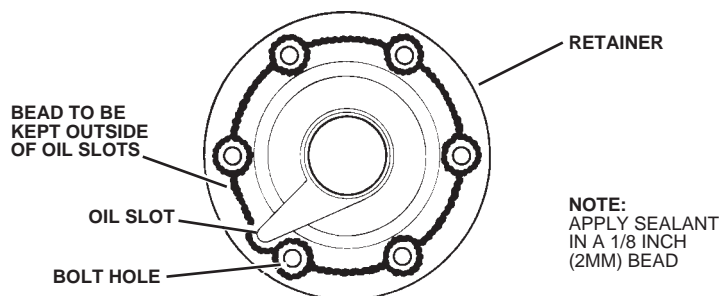

Section 1

General Information

Figure 1-10

AUXILIARY COUNTERSHAFT COVERS AND RANGE PISTON HOUSINGS -TO-AUXILIARY COVER GASKET PATTERN (NINE-SPEED AND TEN-SPEED TRANSMISSION)

- PUT THE PATTERN ON THE AUXILIARY COVER

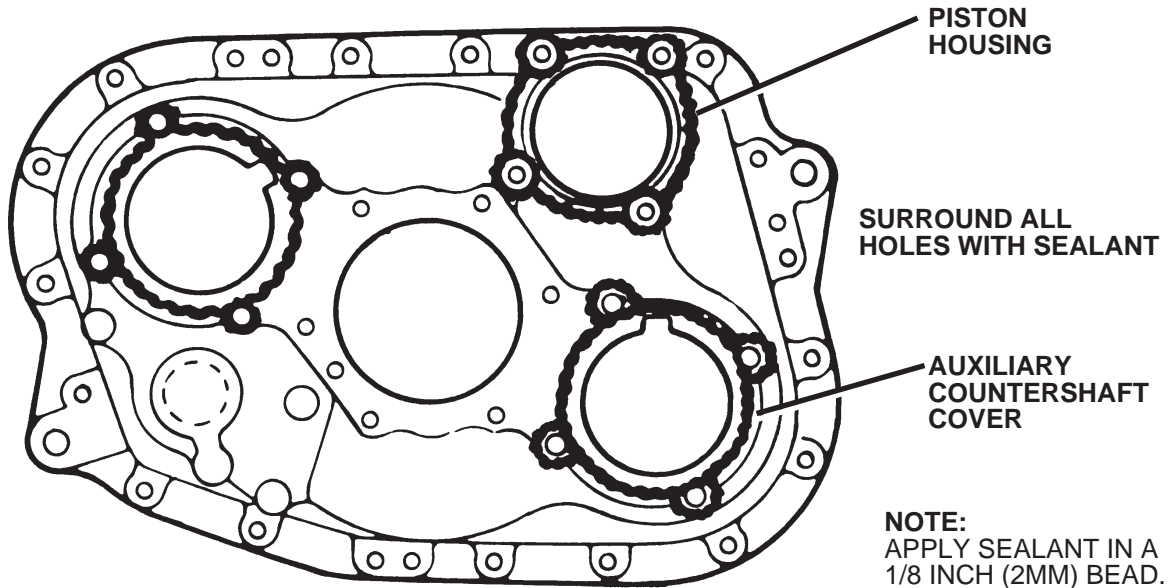
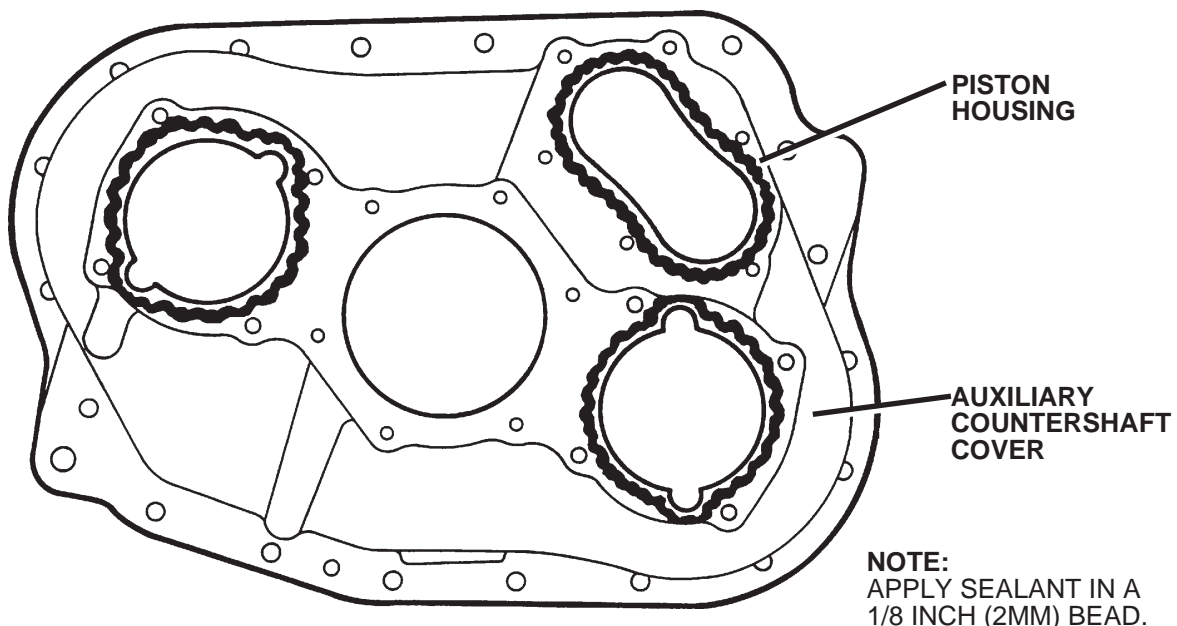

Figure 1-11

AUXILIARY COUNTERSHAFT COVERS AND RANGE PISTON HOUSINGS -TO-AUXILIARY COVER GASKET PATTERN (THIRTEEN-SPEED TRANSMISSION)

- PUT THE PATTERN ON THE AUXILIARY COVER



Inspecting the Parts

It is important to inspect all parts before the transmission is assembled. Check all parts for wear and replace damaged parts. Replacement of damaged parts now, will prevent failure of the assembly later.

Tapered Roller Bearing Cone

NOTE:

The bearing cup and the bearing cone must be replaced as an assembly except when the cup is loose in the bore. If the cup is loose in the bore, install an oversize cup. In all other situations, do

not replace the cup or the cone separately. Replace the cup and the cone in a matched set from the same manufacturer. For replacement part numbers, see the chart in Figure 1–12.

Inspect the cup, the cone, the rollers and the cage of all tapered roller bearings. If any of the following conditions exist, the cup and the cone must be replaced.

1. The outer surface of the large diameter end of the rollers is worn level with or below the center. **Figure 1–13.**
2. The radius at the large diameter end of the rollers is worn to a sharp edge. **Figure 1–13.**

Figure 1–12

Tapered Roller Bearing Cup and Cone Replacement Chart

Component	Bearing Cup and Cone Location	Transmission	Design Level	Part Number
Main Countershaft	Front	All	1	A-1228-W-1349
			2	A-1228-T-1346 ①
	Rear	All	1	A-1228-V-1348
			2	A-1228-S-1345 ②
Auxiliary Countershaft	Front	9- and 10-Speed	1	A-1228-X-1350 ②
			2	A-1228-S-1345 ②
		13-Speed	1	A-1228-U-1373
			2	A-1228-S-1345 ②
	Rear	9- and 10-Speed	1	A-1228-Y-1373
			2	A-1228-U-1347 ③
		13-Speed	1	A-1228-Y-1351
			2	A-1228-U-1347 ③

NOTES:

- ① Use Part Number XCD2139DT.
- ② Use Part Number XC11807DN.
- ③ Use Part Number XC1837DF.

Section 1

General Information

Figure 1-13

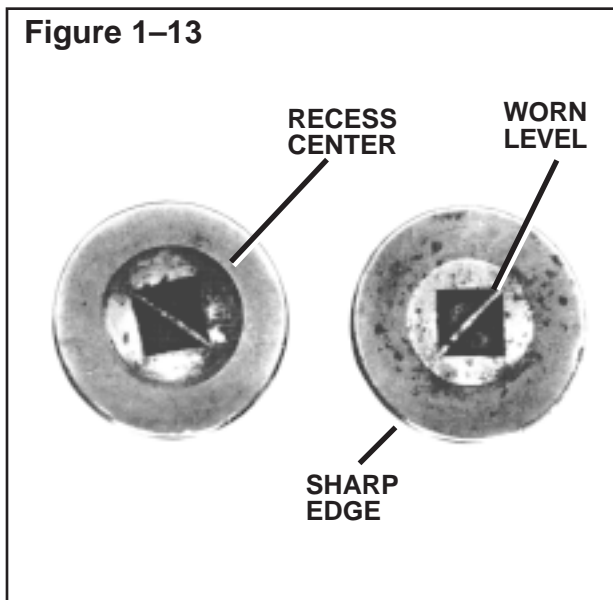

3. A visible roller groove is worn in the inner race surfaces of the cup or the cone. The groove can be seen at the small or large diameter end of both parts. **Figure 1-14.**

Figure 1-14

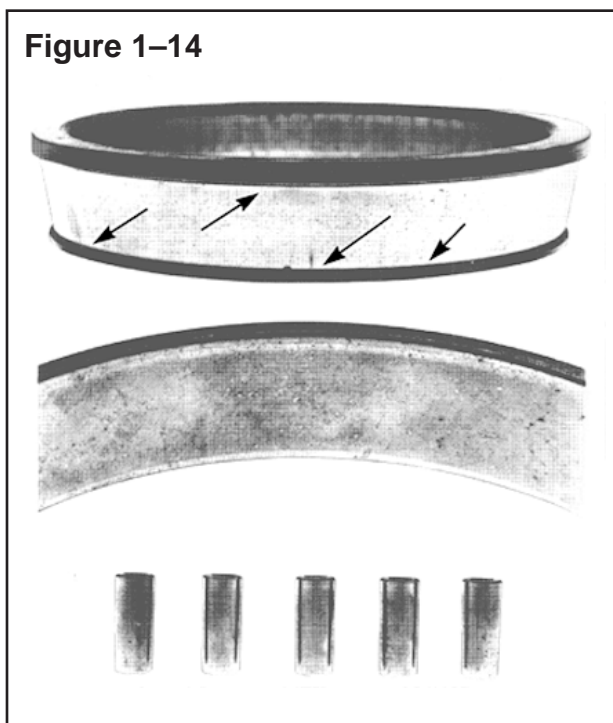

4. Deep cracks or breaks in the surface of the cup, cone inner race or roller. **Figure 1-15.**

Figure 1-15

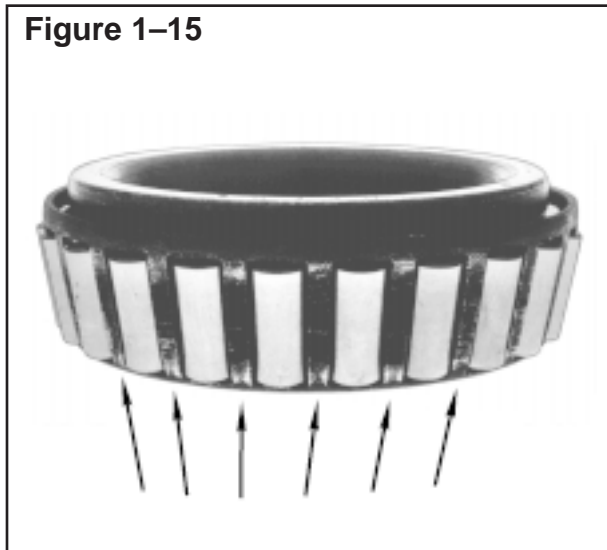

5. Bright wear marks on the outer surface of the roller cage. **Figure 1-16.**
6. Etching or pitting on rollers and on the surfaces of the cup and cone inner race that touch the rollers. **Figure 1-16.**

Figure 1-16

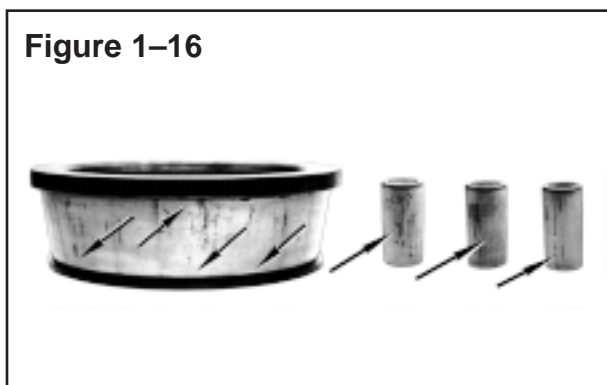

7. Spalling or flaking on the cup and cone inner race surfaces that touch the rollers. **Figure 1-17.**

Figure 1-17



Tapered Roller Bearing Cups

NOTE:

The bearing cup and the bearing cone must be replaced as an assembly except when the cup is loose in the bore. If the cup is loose in the bore, install an oversize cup. In all other situations, do not replace the cup or the cone separately. Replace the cup and the cone in a matched set from the same manufacturer. For replacement part numbers, see the chart in Figure 1-12.

1. Normal cup wear is shown as an even wear across the surface of the cup. Small indentations are acceptable. **Figure 1-18.**

Figure 1-18

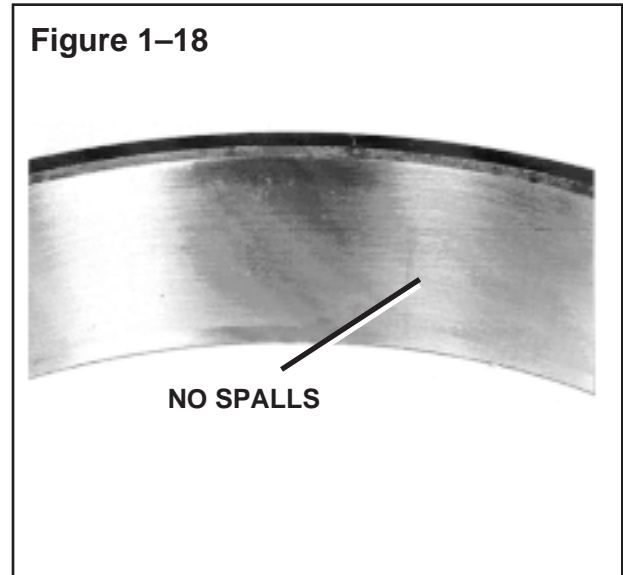

2. Replace cups with small spalling or flaking marks or light bruising. **Figure 1-19.**

Figure 1-19

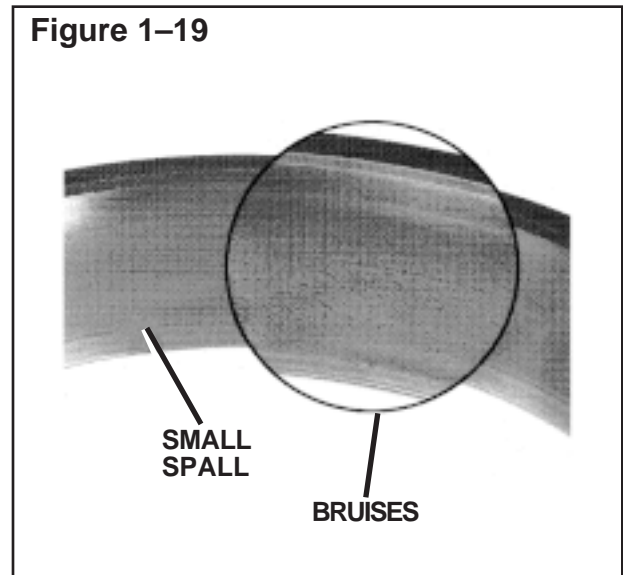

3. Replace cups with large spalls and deep indentations. **Figure 1-20.**

Section 1

General Information

Figure 1–20

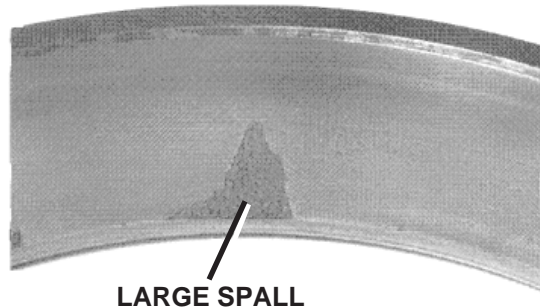

Ball Bearings

Inspect ball bearings for wear and damage. Make sure the bearings rotate in the race. Make sure the outer race is not worn or damaged. On bearings with grooves, make sure the grooves are not worn or damaged. Replace any worn or damaged bearings.

Gears

Inspect the teeth of the gears for wear and damage. Inspect the splines inside the gears for wear and damage. Inspect the gears for cracks or pits. Replace gears that are worn, damaged or cracked.

Shafts

Inspect the splines and the grooves for wear and damage. Make sure the shafts are not twisted. Make sure threads on the end of the shafts are not worn or damaged. Replace any worn or damaged shafts.

O-Rings and Oil Seals

Inspect the O-rings and the oil seals for cuts and cracks. Make sure the parts are not brittle or hard. Replace any worn, damaged or hard O-rings and oil seals.

Clutch Collars

Inspect the teeth of the outside of the clutch collar for wear and damage. Inspect the splines inside the clutch collar for wear and damage. Replace any worn or damaged clutch collars.

Case Housings

Inspect the case housings for cracks. Replace cracked housings.

Top Cover

Inspect the tips of the forks for wear and damage. Make sure the forks are not bent. Make sure the shift rails are not worn or damaged. Inspect the balls and springs for wear or damage. Replace any worn or damaged parts.

Output Yokes

Inspect the seal surface, the splines and the end of the output yoke for wear and damage. Do not sand or grind the seal surface. Replace any worn or damaged parts.

Repairing or Replacing the Parts

Replace worn or damaged parts. The following are some examples to check.

1. Replace any fastener if the corners of the head are worn.
2. Replace the washers if damaged.
3. Replace gaskets and oil seals at the time of transmission repair.
4. Clean the parts and apply new gasket material where required when the transmission is assembled. See “Gasket Sealant” in this section.
5. Remove nicks, mars and burrs from parts having machined or ground surfaces. Use a fine file, india stone or crocus cloth for this purpose (except for yokes).
6. Clean and repair the threads of fasteners and holes. Use a die or tap of the correct size or a fine file for this purpose.

CAUTION

Threads must be clean and undamaged so that accurate adjustments and correct torque values can be applied to fasteners and parts.

7. Use the correct type of Loctite® or equivalent and tighten all fasteners to the correct torque values. See the Torque Chart in Section 20, “Specifications”.

Cleaning the Ground or Polished Parts

WARNING

If you use cleaning solvents, hot solution tanks or alkaline solutions incorrectly, injury can occur. To prevent

injury, follow the instructions supplied by the manufacturer. Do NOT use gasoline to clean parts. Gasoline can explode.

Use a cleaning solvent to clean ground or polished parts and surfaces. Kerosene or diesel fuel can be used for this purpose.

DO NOT USE GASOLINE.

Do **NOT** clean ground or polished parts in a hot solution tank or with water, steam or alkaline solutions. These solutions will cause corrosion of the parts.

Cleaning the Rough Parts

Rough parts can be cleaned with the ground or polished parts. Rough parts also can be cleaned in hot solution tanks with a weak alkaline solution. Parts must remain in the hot solution tanks until they are completely cleaned and heated.

Drying the Cleaned Parts

must be dried immediately after cleaning. Dry parts with clean paper, rags, or compressed air.

Preventing Corrosion and Rust on Cleaned Parts

Apply lubricant to cleaned and dried parts that are not damaged and are to be immediately assembled.

If parts are to be stored, apply a special material that prevents corrosion and rust to all surfaces. Store the parts inside special paper or other material that prevents corrosion and rust.

Section 2

Lubrication and Maintenance

Transmission Oil Specifications

 **CAUTION**

Use only the specified type of single weight oils. Do not use multi-viscosity oils or EP (Extreme Pressure) gear oils. Multi-viscosity oils and EP gear oils may damage components. The use of multi-viscosity or EP gear oils voids the warranty.

Use the specified type of single weight oil when adding or replacing oil. Use the correct type of oil for the outside temperature. Engine oil, mineral oil and full-synthetic lubricants are recommended. **DO NOT MIX OILS.**

See the chart in **Figure 2–1** for oil specifications.

Transmission Oil Coolers

Use a transmission oil cooler for any of the following.

- The transmission operating temperature is always more than 225°F (107°C) at continuous operation or 275°F (135°C) at intermittent operation.
- The engine has a horsepower rating of 399 HP or more. Some aerodynamic vehicles with less than 399 HP may require a cooler due to the lack of air which flows over the transmission to dissipate heat.

Figure 2–1		
LUBRICANT TYPE	GRADE(SAE)	OUTSIDE TEMPERATURE
Full-Synthetic Oil, Meritor Specification 0-81	50	All
Heavy-Duty Engine Oil A.P.I.-CD, -CE, -SF or -SG (Current API Designations Acceptable)* MIL-L-2104B, C, D or E	50 40 30	Above 10° F (-12° C) Above 10° F (-12° C) Above -15° F (-26° C)
Mineral Oil with Rust and Oxidation Inhibitor A.P.I.-GL-1	90 80	Above 10° F (-12° C) Above -15° F (-26° C)
<p> CAUTION</p> <p><i>Use only the specified type of single weight oils. Do not use multi-viscosity oils or EP (Extreme Pressure) gear oils. Multi-viscosity oils and EP gear oils may damage components. The use of multi-viscosity or EP gear oils voids the warranty.</i></p>		

Scheduled Maintenance

Every 10,000 Miles (16,000 km) of Vehicle Operation.

- Check and adjust the oil level in the transmission.
- Check the condition of the breather vent.
- Check the torque of the fasteners.
- Inspect for leaks or damage on the transmission. Service as necessary.

Every 50,000 Miles (80,000 km) of Vehicle Operation (Approved Petroleum Base and Heavy-Duty Engine Oils)

- Drain and replace the oil in the transmission with approved petroleum base and heavy-duty engine oils.

Every 500,000 Miles (400,000 km) of Vehicle Operation (Approved Full-Synthetic Oils)

- Drain and replace the oil in the transmission with approved full-synthetic oils.

Checking and Adjusting the Oil Level

See Figure 2-2.

1. Make sure of the following before checking the oil level.
 - a. The oil is at room temperature
 - b. Wait ten minutes after the vehicle is parked before checking the level.
 - c. Make sure the vehicle is parked on a level surface.
2. Clean the area around the fill plug. Remove the fill plug from the side of the transmission.

CAUTION

Use only the specified type of single weight oils. Do not use multi-viscosity oils or EP (Extreme Pressure) gear oils. Multi-viscosity oils and EP gear oils may damage components. The use of multi-viscosity or EP gear oils voids the warranty.

3. Check the oil level. The oil level must be even with the bottom of the hole of the fill plug.

If foam appears when the plug is removed, air has not been removed from the oil. Install the plug and wait for the air to dissipate.

If oil flows from the hole when the plug is loosened, the oil level is high. Let the oil drain until the oil is at the specified level.

If the oil level is below the bottom of the hole of the fill plug, add the specified oil.

4. Install and tighten the fill plug to 35-50 lb-ft (48-67 N.m). 
5. Operate the vehicle for five minutes. Check for correct operation.

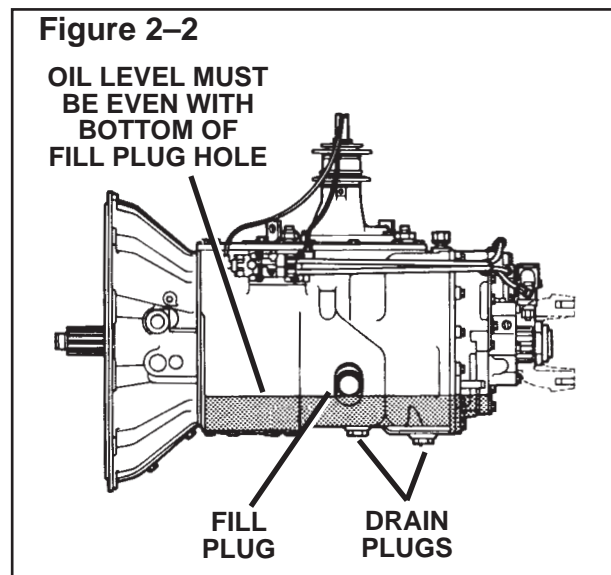

Section 2

Lubrication and Maintenance

Checking the Condition of the Breather Vent

Make sure the breather vent is not damaged. Remove all dirt and oil from the screen in the breather vent. **Figure 2-3.**

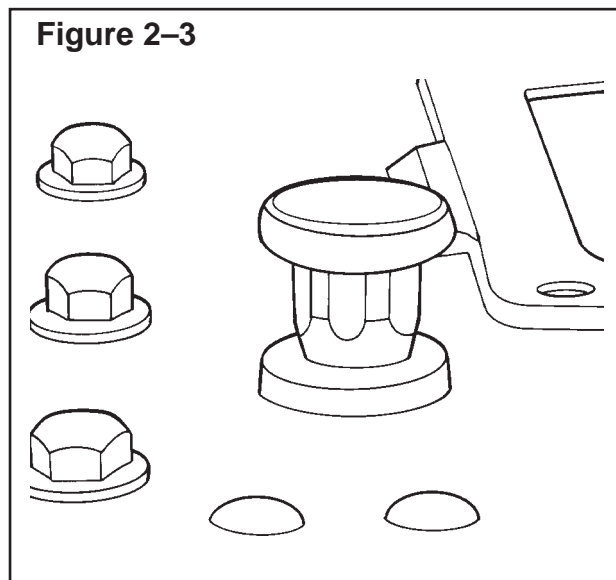

Checking the Torque of the Fasteners

Check the torque on the following. See the torque chart in Section 20, "Specifications".

- Clutch housing to engine flywheel.
- Top cover housing to main case.
- All electrical switches on the top cover housing.
- Drain and fill plugs.
- PTO covers to main case.
- Auxiliary case to main case.
- Output bearing retainer to auxiliary case.
- Piston housing cover to auxiliary case.
- Auxiliary countershaft cover to auxiliary case.
- Transmission to frame brackets.
- Output yoke to output shaft.
- Shift cover housing to top cover housing.

Inspecting the Transmission for Leaks and Damage

Inspect the transmission for cracks, leaks and damage. Make sure the leaks are transmission oil.

CAUTION

Repair all leaks. If leaks are not repaired, the transmission will be damaged.

Inspect the following areas for leaks.

- The output yoke and the oil seal in the output bearing retainer on the auxiliary case.
- The PTO covers on the main case.
- The auxiliary case to main case.
- The main case and the clutch housing.
- The clutch housing to flywheel housing.
- The auxiliary countershaft covers.
- The slave valve to the main case.
- The shift lever and tower assembly to the top cover.
- The top cover to the main case.
- The fill and the drain plugs.
- The output bearing retainer to the auxiliary case.
- The input bearing retainer to the main case.
- Speedometer bore or electronic speed pick-up in the output bearing retainer.

Draining and Replacing the Transmission Oil

NOTE:

Drain the oil when the transmission is hot.

1. Make sure the vehicle is parked on a level surface. Put a large container under the transmission. Put a screen on top of the container.

NOTE:

Meritor recommends replacing the magnetic drain plug each time the oil is changed. Use the correct part. Pipe plugs will leak if used as a drain plug.

The magnetic drain plug can be reused if, after cleaning, the plug has a minimum pick-up capacity of 1.5 pounds (0.7 kilograms) of low carbon steel.

2. Remove the drain plugs from the bottom of the transmission. Drain and discard the oil.

Inspect the O-rings on the drain plugs. Replace worn or damaged O-rings.

Inspect the screen on top of the container for metal particles and damaged particles. Service the transmission as necessary.

3. If the transmission is disassembled or replaced and an oil cooler is used, remove the cooler. Remove and discard the oil from the cooler and the oil lines. Install the oil cooler and the lines. Tighten the fittings to the specified torque of the manufacturer of the vehicle.

4. Install and tighten the drain plug to 35-50 lb-ft (48-67 N.m).
5. Clean the area by the fill plug. Remove the fill plug from the side of the transmission.



CAUTION

Use only the specified type of single weight oils. Do not use multi-viscosity oils or EP (Extreme Pressure) gear oils. Multi-viscosity oils and EP gear oils may damage components. The use of multi-viscosity or EP gear oils voids the warranty.

6. Add the specified transmission oil through the hole for the fill plug.

Add the oil until the oil level is even with the bottom of the hole of the fill plug. **Figure 2-4.**

7. Install and tighten the fill plug to 35-50 lb-ft (48-67 N.m).
8. Operate the vehicle for five minutes. Check for correct operation.

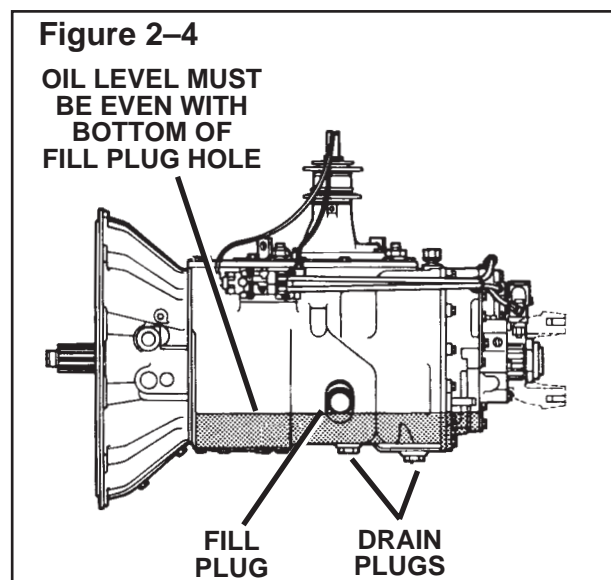

Section 2

Lubrication and Maintenance

Adjusting the Linkage for the Remote Control Assembly

Cab-Over-Engine (COE) vehicles use a remote control assembly on top of the transmission. Linkage connects the inner shift lever to a shift lever in the cab of the vehicle.

The linkage must be adjusted for correct operation. See the procedure of the manufacturer of the vehicle.

Lubricating the Remote Control Assembly

Apply grease to the fittings on the linkage at the interval specified by the manufacturer of the vehicle. Use the grease specified by the manufacturer of the vehicle.



WARNING

To prevent serious eye injury, always wear safe eye protection when doing maintenance or service.

Removing the Shift Lever and Tower Assembly

1. Shift the transmission into the **NEUTRAL** position. Remove the air from the air supply system.
2. Disconnect the air lines from the shift knob at the slave valve.
3. Remove the capscrews and the washers that fasten the shift tower housing to the top cover housing.

NOTE:

Do not lose any detent springs or balls when the shift tower housing is removed. If any springs or balls come out, install the parts in the correct bore. Install the ball before the spring is installed.

4. Remove the shift tower housing and lever assembly and the gasket from the top cover housing. Discard the gasket **Figure 3-1**.
5. Remove any gasket material between the shift lever housing and the top cover housing.

Figure 3-1

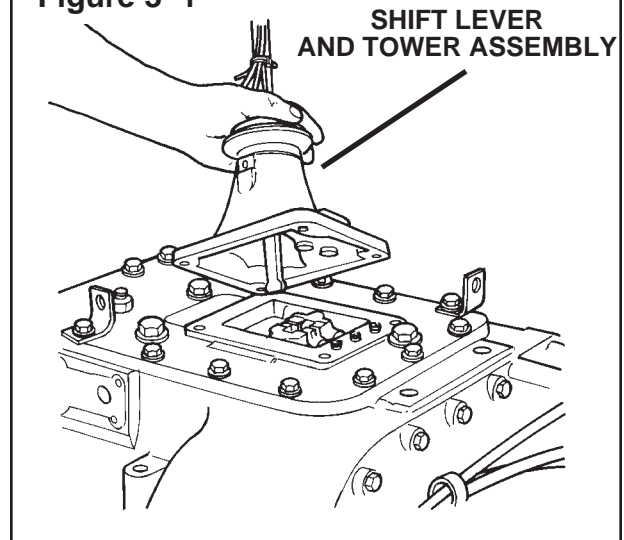

Installing the Shift Lever and Tower Assembly

1. Make sure the transmission is in the **NEUTRAL** position. **Figure 3-2**.

Figure 3-2

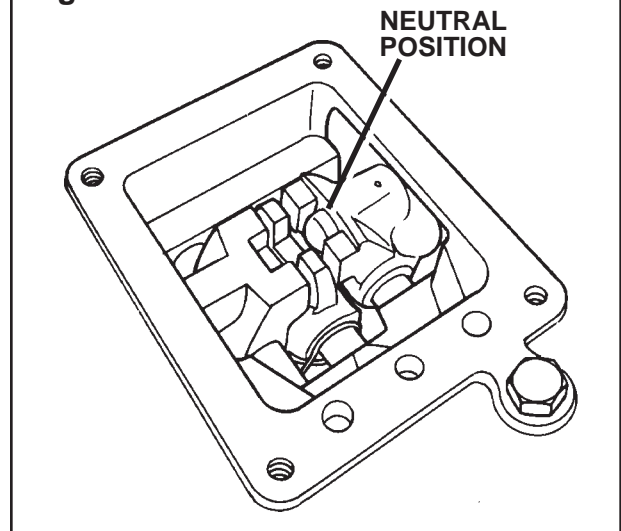

Section 3

In-Vehicle Service



CAUTION

The aluminum housing uses a gasket that is different from the gasket on the cast iron housing. Use the correct gasket. If the wrong gasket is used, the area between the shift tower housing and the top cover housing will leak.

2. Install a new gasket for the shift tower housing on the top cover housing.
3. Put the shift tower housing in position on the top cover housing. Make sure the bottom of the lower shift lever is correctly installed between the forks and the sleeves in the top cover housing. **Figure 3-1.**
4. Install the mounting capscrews and washers on the shift tower housing. Tighten the capscrews to 35-45 lb-ft (48-61 N.m) in the sequence shown in **Figure 3-3.**

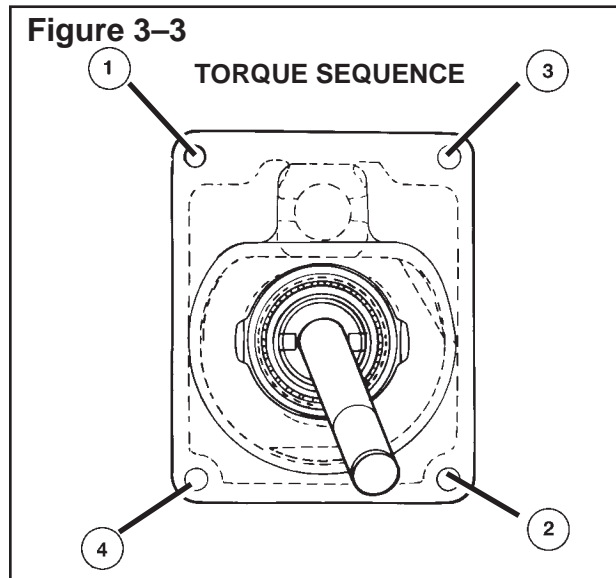

5. Install the cover (if used) around the shift tower housing.
6. Operate the vehicle. Make sure the transmission operates correctly in all gears.

Removing the Slave Valve

See Figure 3-4.

1. Remove the air from the air supply system.
2. Disconnect and mark the air lines from the slave valve by pushing on the fitting and pulling on the line.
3. Remove the mounting capscrews and the washers from the slave valve. Remove the slave valve.

On Design Level 1 Transmissions, remove and replace the gasket between the slave valve and the case.

On Design Level 2 Transmissions, a gasket for the slave valve is not used.

4. Remove the actuator pin, the spring and the sleeve from the bore in the main case. **Figure 3-5.**

Installing the Slave Valve

See Figure 3-4.

1. Lubricate the O-rings on the sleeve with a silicone lubricant such as Dow Corning #111 Silicone Grease or equivalent.

NOTE:

If the part number on the sleeve is 2245-H-1126 or 2245-A-1067, replace the sleeve with part number 2245-U-1165.

2. Install the small end of the sleeve in the bore in the slave valve.
3. Install the spring on the actuator pin. Install the pin and spring assembly in the main case. Make sure the tip on the pin is toward the slave valve **Figure 3-5.**

Figure 3-4

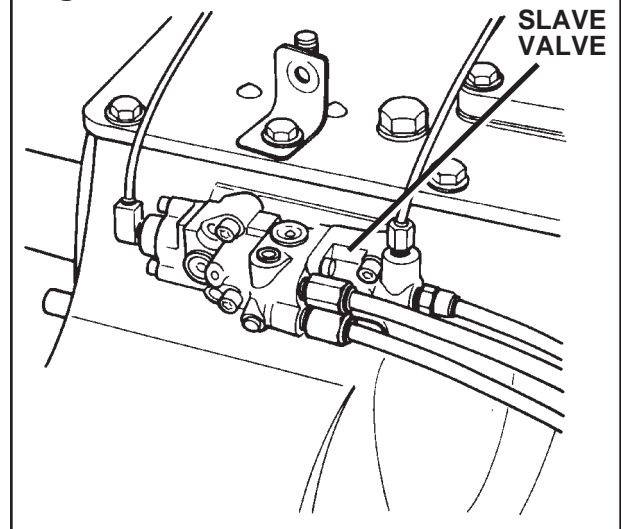
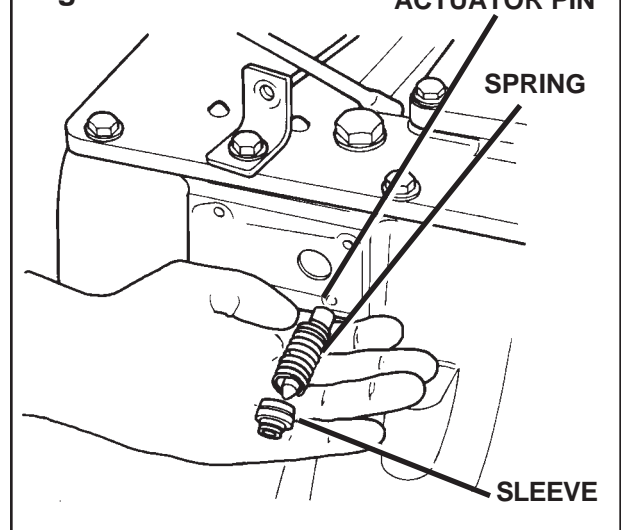

Figure 3-5



4. **On Design Level 1 Nine-Speed Transmissions only,** install a new gasket in position on the back of the slave valve. **Design Level 2 Nine and Ten-Speed Transmissions do not use a gasket.**
5. Install the slave valve and the gasket in position on the main case.
6. Install the mounting capscrews and washers for the slave valve. Tighten the capscrews to 85-115 lb-in (10-12 N.m). **T**

Section 3

In-Vehicle Service

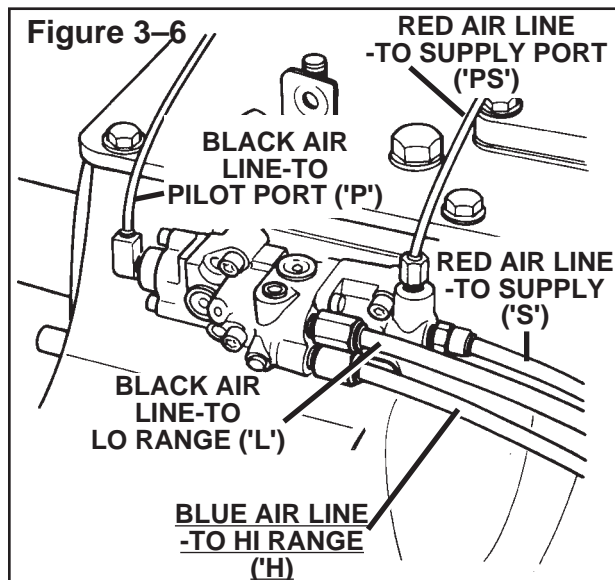

7. Connect the air lines to the slave valve. **Figure 3-6.**
 - a. Connect the **BLACK** 1/8 or 5/32 inch outer diameter air line to the pilot port fitting (stamped letter '**P**' on the valve).
 - b. Connect the **RED** 1/8 or 5/32 inch outer diameter air line to the pilot supply port fitting (stamped letters '**PS**' on the valve).
 - c. Connect the **RED** 1/4 or 5/16 inch outer diameter air line to the supply fitting (stamped letter '**S**').
 - d. Connect the **BLACK** 1/4 or 5/16 inch outer diameter air line to the **LO** range fitting (stamped letter '**L**').
 - e. Connect the **BLUE** 1/4 or 5/16 inch outer diameter air line to the **HI** range fitting (stamped letter '**H**').
8. Operate the vehicle. Check the air shift system for correct operation.

Removing the Air Filter and Regulator Assembly

See Figure 3-7.

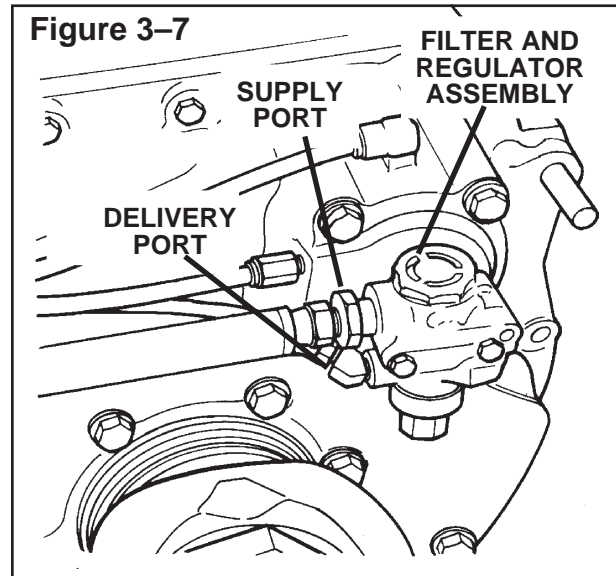

1. Remove the air from the air supply system.
2. Disconnect and mark the air lines on the filter and regulator assembly.
3. Remove the mounting capscrews and the washers from the filter and regulator assembly. Remove the filter and regulator assembly.
4. On thirteen-speed transmissions, remove the O-ring from between the filter and regulator assembly and the piston housing cover. **Figure 3-8.**

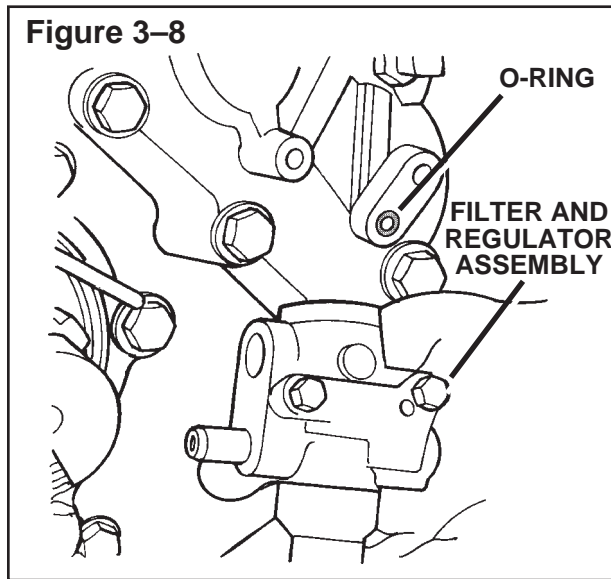

Installing the Air Filter and Regulator Assembly

See Figure 3-7.

1. On thirteen-speed transmissions, lubricate the O-ring with a silicon lubricant such as Dow Corning #111 Silicone Grease or equivalent. Put the O-ring for the filter and regulator assembly in the port in the piston housing cover. **Figure 3-7.**
1. Put the filter and regulator assembly on the top of the range cylinder.
2. Install the mounting capscrews and washers. Tighten the capscrews to 85-115 lb-in (10-12 N.m). **T**
3. Connect the **RED** air line to the **DELIVERY** port on the filter and regulator assembly. Connect the air line from the air supply system to the **SUPPLY** port on the slave valve (stamped letter "S" on the valve). **Figure 3-9.**
4. Operate the vehicle. Check the air shift system for correct operation.

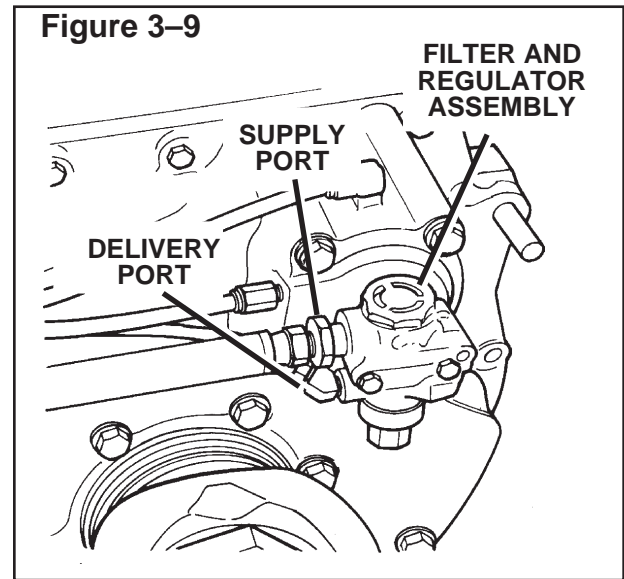

Removing the Output Yoke and the Oil Seal

NOTE:

Before replacing the oil seal, make sure of the following:

1. *The oil seal leaks. The lip of the oil seal is packed with grease. Under normal conditions, the area between the lip of the oil seal and the yoke is "wet". To check if the seal leaks, clean the area around the seal (Make sure the oil is at the specified level.). If drops of oil appear, the seal must be replaced. If the area between the lip of the seal and the yoke is "wet", do not replace the oil seal.*
2. *The correct oil is in the transmission. If the wrong oil is used, the oil seal will be damaged and leak. See "Transmission Oil Specifications" in Section 20.*
3. *The yoke is not worn or damaged. If the yoke is worn or damaged, replace the yoke. Do not repair yokes.*

Section 3

In-Vehicle Service

4. Use the correct tool and the correct procedure to install the seal. Use **Seal Driver Tool, Meritor Part Number 3256-Z-1014 or Kent-Moore Part Number J-39161** to install the seal. Do not remove the output bearing retainer to install the seal. If the correct tool and/or the correct procedure is not used, the seal will leak.



WARNING

Do not work under a vehicle supported only by jacks. Jacks can slip or fall over and cause serious personal injury. Support the vehicle with safety stands. Block the wheels to prevent the vehicle from moving.

1. Put the transmission in **NEUTRAL**. Make sure the parking brake is applied.
2. Disconnect the driveshaft from the output yoke of the transmission.
3. Put a holding tool, such as Kent-Moore Tool, J-3453, Flange/Yoke Holding Bar, or equivalent, on the yoke.
4. Put a 2-3/4 inch socket on the nut that fastens the yoke to the output shaft. Remove and discard the nut.

Figure 3-10.

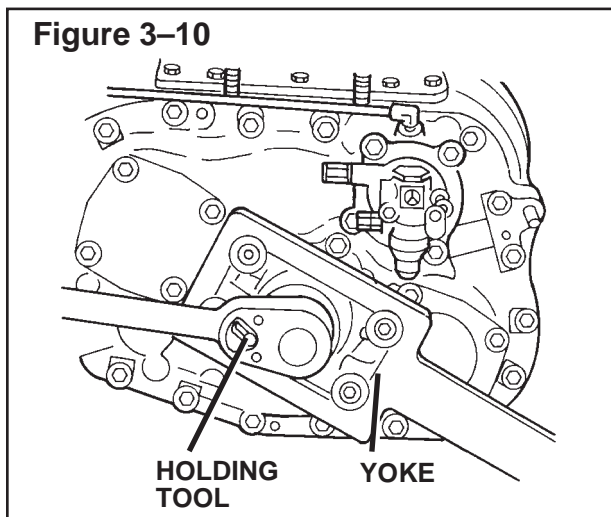

5. Remove the yoke from the output shaft. Remove the speedometer tone ring or drive gear from the yoke. Replace the yoke if worn or damaged.
6. Use a slide hammer and puller, such as Snap-On Light Duty Puller Set, CG2400B, or equivalent, to remove the seal from the retainer. Discard the seal. **Figure 3-11.**

Figure 3-11

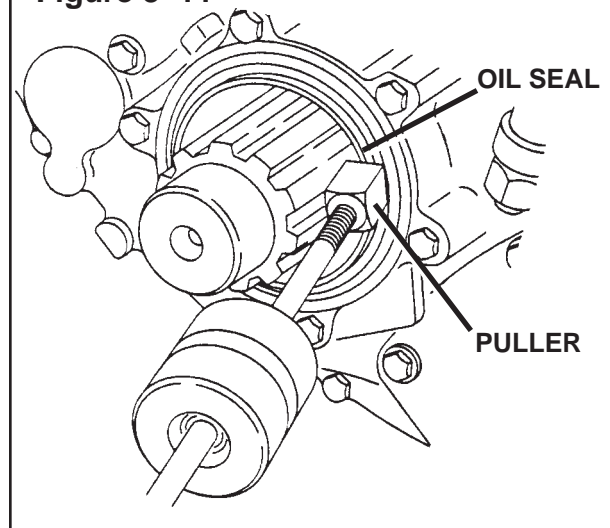

Installing the Oil Seal and the Output Yoke

1. Inspect the bore for the seal in the output bearing retainer and the seal journal on the output yoke for wear or damage. Replace the retainer if worn or damaged.
2. Lubricate the outer surface of the output bearing retainer where the seal is installed with the oil that is used in the transmission.

Section 3 In-Vehicle Service

! CAUTION

Hold the seal only on the outer diameter. Do not touch the inner diameter of the seal. Touching contaminates the inner diameter of the seal and causes a leak between the shaft and the seal.

3. Install the oil seal in the output bearing retainer.

! CAUTION

Use only the specified seal driver tool. If a different driver tool is used, the seal will not be installed at the correct depth and will leak.

4. Use seal driver tool, Meritor Part Number 3256-Z-1014 or Kent-Moore Part Number J-39161, to install the seal. Clean and inspect the tool. Replace the tool if the area that touches the seal is worn or damaged. **Figure 3-12.**

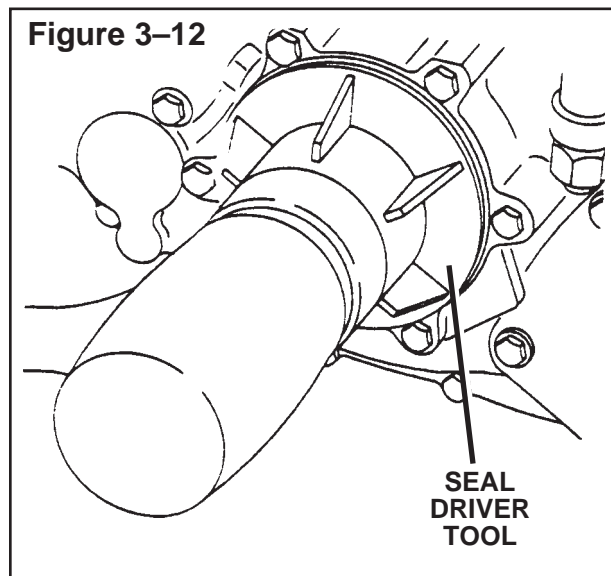

On 115 and 125 Series transmission, use the sleeve inside the seal driver tool.

On 135, 145 and 155 Series transmissions, remove the sleeve from the inside of the seal driver tool.

5. Clean the seal driver tool. Put the oil seal on the seal driver tool so that the spring is away from the tool. Make sure the seal is flat against the surface of the tool. **Figure 3-13.**

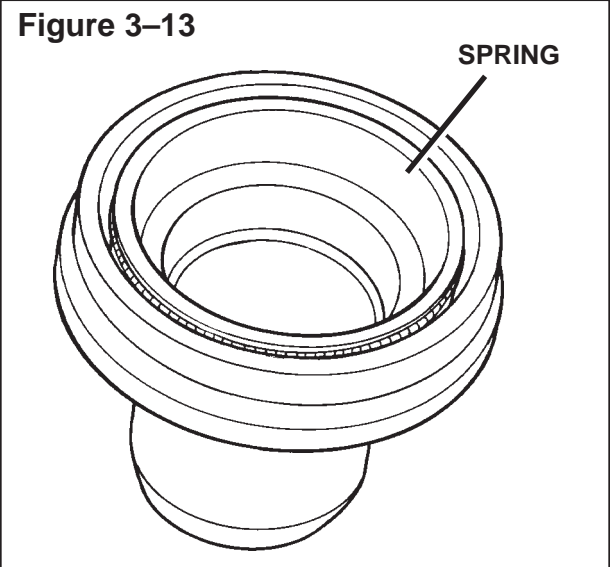

6. Drive the seal into the retainer until the flange on the tool touches the retainer. Make sure there are no gaps between the tool and the retainer.

! CAUTION

Use a cleaning solvent to clean the yoke. Do not use a crocus cloth to polish the journal of the yoke. If a crocus cloth is used, the seal will leak.

7. Clean the yoke with a cleaning solvent. Lubricate the journal and splines in the yoke with the oil that is used in the transmission.

! CAUTION

Make sure the speedometer drive gear or tone ring is correctly installed or the output shaft seal may be damaged when the yoke is installed.

8. Install the speedometer drive gear or tone ring on the yoke.

Section 3

In-Vehicle Service

9. Install the yoke on the output shaft.
Put a holding tool on the yoke. **Figure 3-14.**

⚠ CAUTION

Do not tighten the yoke nut more than 500 lb-ft (677 N.m) or the output bearing will be damaged.

10. Install a new nut that fastens the yoke on the output shaft. Tighten the nut to 450-500 lb-ft (610-677 N.m). **Figure 3-14.**



11. Connect the driveshaft to the output yoke. Install and tighten the fasteners according to the specifications and procedures of the manufacturer of the vehicle.
12. Operate the vehicle. Make sure the oil seal does not leak.

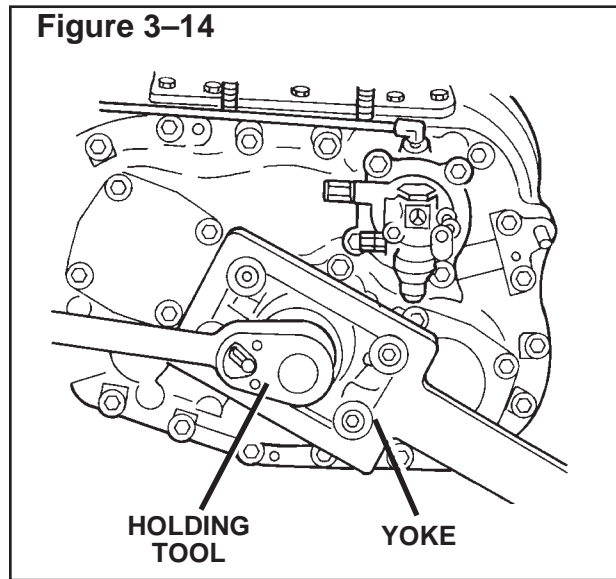

Removing and Installing the Remote Control Assembly

NOTE:

See the recommended procedure from the manufacturer of the vehicle. The following is a general procedure to remove and install the remote control assembly.

1. Raise the cab according to the procedure of the manufacturer of the vehicle.
2. Measure the length of the adjusting rod from the centerline of each ball socket as shown in **Figures 3-15 and 3-16**. Mark the location of the adjusting rod and the ball sockets.
3. Disconnect the linkage to the remote control assembly.
4. Remove the capscrews that fasten the remote control housing to the top cover housing. Remove the housing. Remove and discard the gasket. Remove any gasket material between the remote control housing and the top cover housing.
5. Install a new gasket on the transmission.
6. Put the remote control housing in position. Install and tighten the capscrews to 35-45 lb-ft (47-61 N.m). **T**
7. Connect the linkage to the outer shift lever of the remote housing. Install and tighten the nut to 12-18 lb-ft (17-24 N.m). **T**
8. Adjust the length of the adjusting rod to the distance measured in step 2 or to the distance specified by the manufacturer of the vehicle. **Figures 3-15 and 3-16**.

To adjust the distance, loosen the jam nuts and move the rod to the correct distance. Tighten the jam nuts to 35-50 lb-ft (47-67 N.m). **T**

8. Adjust the linkage according to the procedure of the manufacturer of the vehicle.
9. Operate the vehicle and check for correct operation.

Figure 3-15

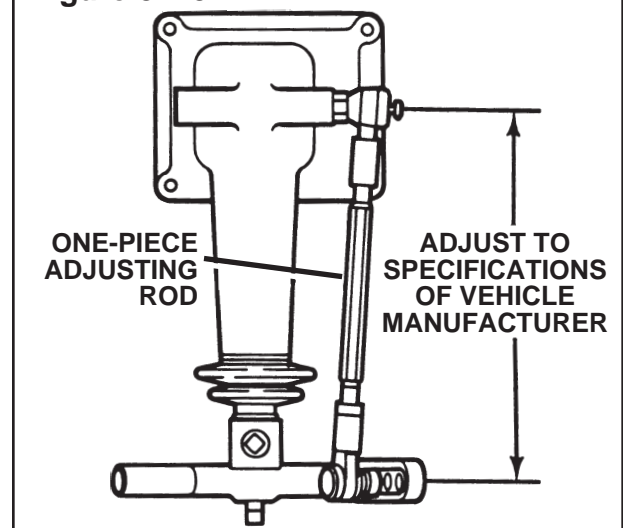
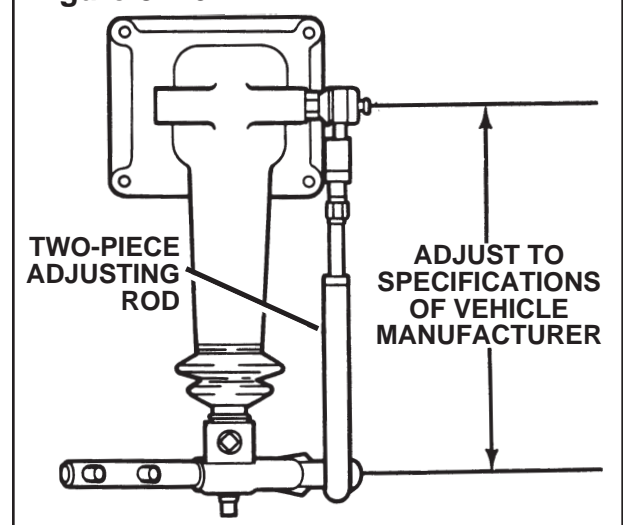

Figure 3-16



Section 4

Removing and Installing the Transmission



WARNING

To prevent serious eye injury, always wear safe eye protection when doing maintenance or service.

Removing the Transmission

See the recommended procedure from the manufacturer of the vehicle to remove the transmission. Some vehicles require that the engine is supported when the transmission is removed. The following is a general procedure to remove the transmission.

1. Remove the air from the air supply system.
2. Put a large container under the transmission. Remove both drain plugs (and if necessary, the cooler lines). Drain and discard the oil. **Figure 4-1.**

Figure 4-1

OIL LEVEL MUST BE EVEN WITH BOTTOM OF FILL PLUG HOLE

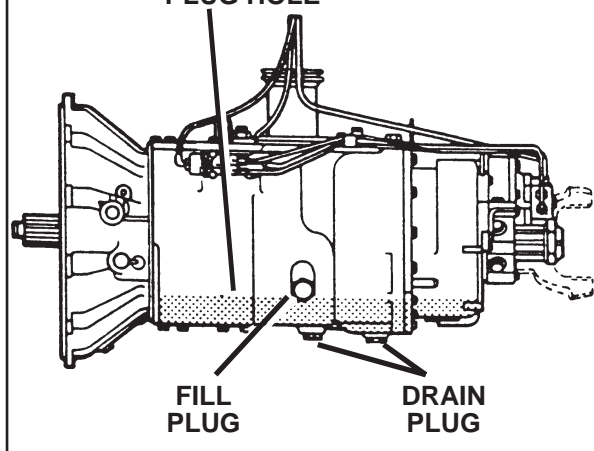

3. Remove the shift lever from the transmission. If necessary, remove the shift tower assembly from the transmission.

4. Put marks on the yoke or the flange of the driveshaft and the output shaft of the transmission. The marks on the driveshaft and the output shaft make sure the driveshaft is correctly reinstalled.
5. Remove the driveshaft.
6. Disconnect all the electrical connections (if used) for the back-up lamp switches, the neutral safety switch and the temperature indicator.
7. Disconnect and mark all the air lines from the transmission.
8. Disconnect the speedometer connections from the output bearing retainer.
9. If used, remove the spring from the clutch lever on the transmission. Mark and disconnect the clutch linkage from the clutch housing on the transmission.
10. If a hydraulic system is used on the clutch, disconnect the push rod and the spring from the release fork. Remove the hydraulic cylinder from the bracket on the transmission. Use wires to support the cylinder on the frame.



WARNING

Make sure the transmission is securely supported on the overhead hoist or the jack. If the transmission is not securely supported, the transmission may fall and cause serious personal injury or damage.

11. Support the transmission with an overhead hoist or with a transmission jack. Make sure the transmission is securely supported.
12. Remove the fasteners that attach the transmission to the brackets on the frame.

Section 4 Removing and Installing the Transmission

CAUTION

Make sure the transmission does not hang by the input shaft. The clutch assembly and the pilot bearing will be damaged if the transmission is supported by the input shaft.

10. Remove the bolts and the washers that attach the clutch housing to the engine. Pull the transmission straight out from the flywheel housing. Remove the transmission from the vehicle.

Figure 4-2.

11. If used, remove the clutch brake assembly from the input shaft of the transmission. Inspect transmission input bearing retainer surface for excessive wear which can affect the clutch adjustment. **Figure 4-3.**

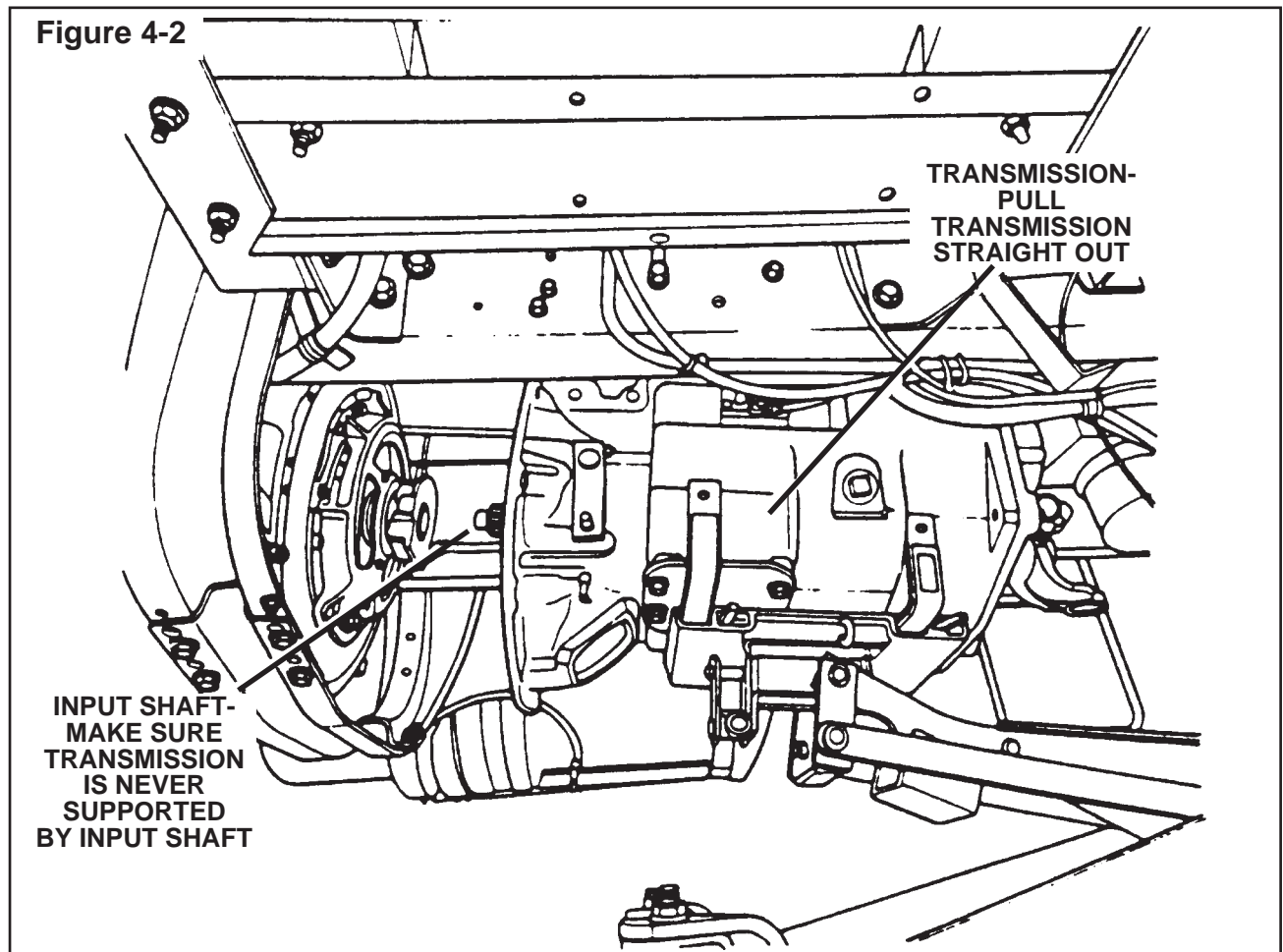
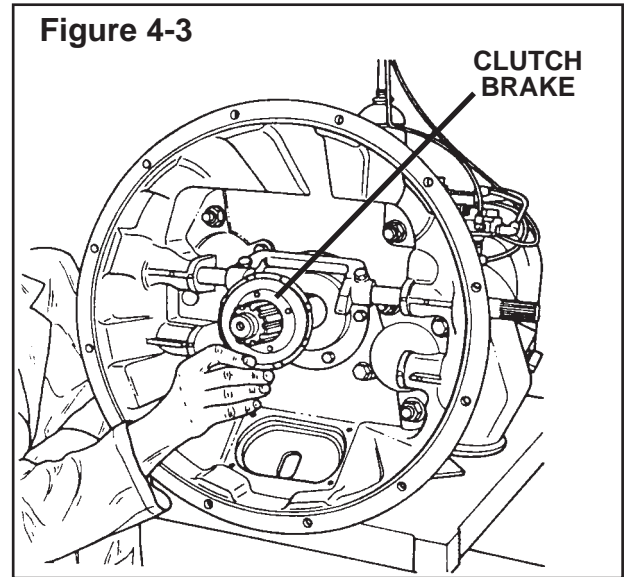

Section 4

Removing and Installing the Transmission

Installing the Transmission

See the recommended procedure from the manufacturer of the vehicle to install the transmission. The following is a general procedure to install the transmission.

1. Inspect the clutch housing for wear and damage. Replace worn and damaged housings.
2. Inspect the cross shaft bores in the housing. Make sure plugs are in the bores that are not used. If the bores are not plugged, dirt and contaminants go into the clutch housing and damage the clutch. **Figure 4-4.**

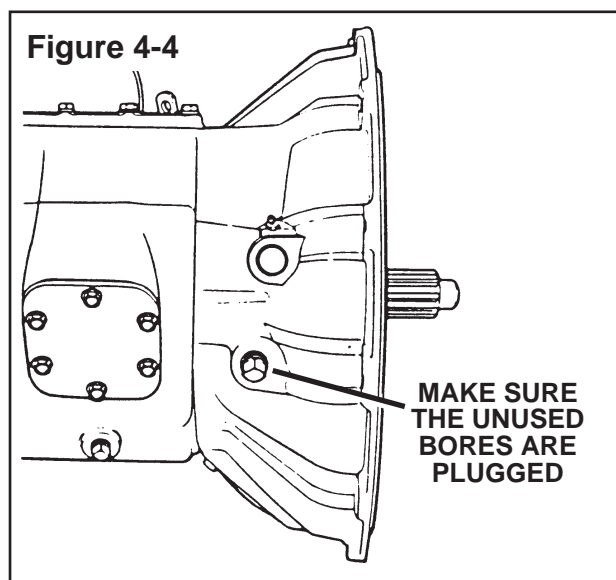

3. Make sure an inspection cover is installed on the bottom of the clutch housing. If an inspection cover is not used, dirt and contaminants go into the clutch housing and damage the clutch. **Figure 4-5.**

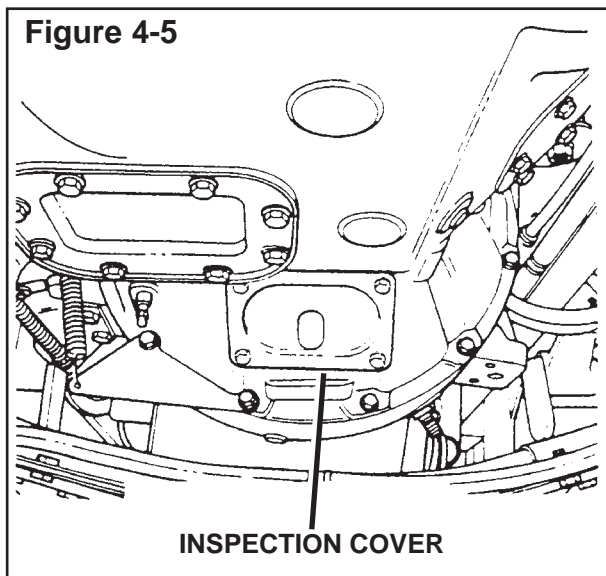

4. Inspect the input bearing retainer on the transmission. Check the area where the clutch brake touches the retainer. Replace worn or damaged retainers.
5. Measure the distance from the top of the splines on the input shaft to the top of the bearing retainer as shown in **Figure 4-6.** If the distance is more than 8.72 inches (221.48 mm), the input bearing retainer is worn and must be replaced.

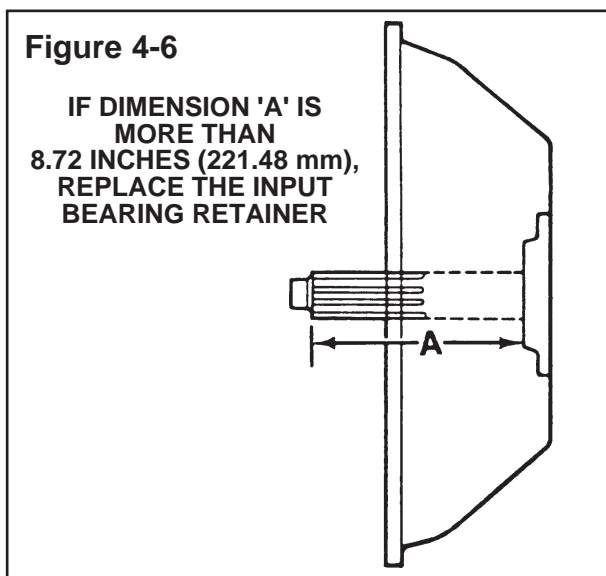

Removing and Installing the Transmission

6. Inspect the shaft and the release fork. Make sure the release fork is straight and the tips of the fork are not worn or damaged. Replace forks that are worn or damaged. **Figure 4-7.**

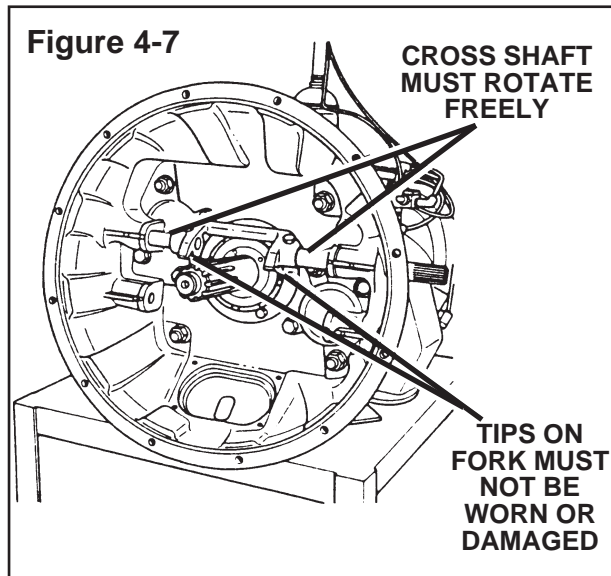

7. Make sure the cross shafts rotate freely in the clutch housing. Make sure the shaft does not have any excessive radial (side-to-side) movement in the housing. Inspect the bushings for the shaft in the housing. Replace bushings and shafts that are worn or damaged.
8. Inspect the splines on the input shaft. Make sure the splines are not worn or damaged. Inspect the area of travel for the release bearing for damage. Use an emery cloth to remove small scratches from the input shaft. Replace input shafts that are worn or damaged. **Figure 4-8.**
9. Inspect the end of the input shaft where the pilot bearing is installed. If the end is worn or damaged, replace the input shaft and the pilot bearing. **Figure 4-8.**

Figure 4-8

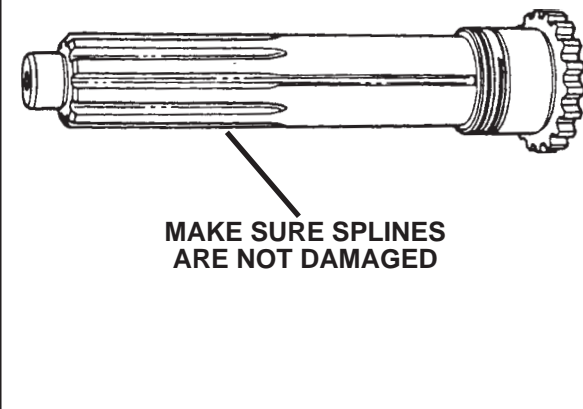

10. Inspect the clutch brake. If the tabs or the body is worn or damaged, replace the clutch brake. Inspect the lining material on the clutch brake. Replace the clutch brake if the lining is worn or damaged. **Figure 4-9.**
11. If removed, install the clutch brake on the input shaft of the transmission. Make sure the large part of the brake is toward the input bearing retainer and the tabs on the brake engage the slots in the input shaft. **Figure 4-9.**

Figure 4-9

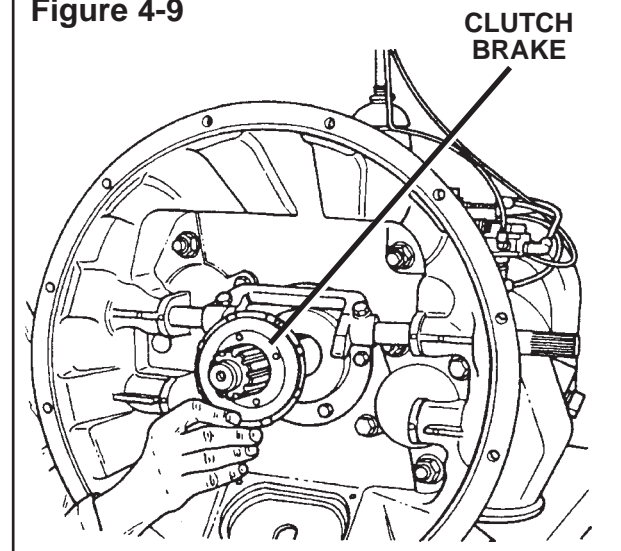

Section 4

Removing and Installing the Transmission

12. Put the transmission in gear.

! WARNING

Make sure the transmission is securely supported on the overhead hoist or jack. If the transmission is not securely supported, the transmission may fall and cause serious personal injury or damage.

13. Put the transmission on a transmission jack or an overhead hoist.

14. If installed, remove the inspection cover from the clutch housing.

! CAUTION

Be careful when installing the input shaft of the transmission in the hubs of the disc. If the transmission is forced or jammed, the clutch discs or the clutch housing will be damaged. Also, do not let the transmission hang or be

supported by the clutch or the discs. The clutch or the discs are damaged when the transmission is not correctly installed.



15. Install the transmission according to the following procedure. **Figure 4-10.**

- Put the transmission so that the input shaft is aligned with the pilot bearing.
- Move the input shaft into the clutch housing. Make sure the two tips of the release fork are installed between the release bearing assembly and the clutch cover.
- If necessary, rotate the output shaft of the transmission to align the splines on the input shaft with the teeth in the hubs of the clutch discs.

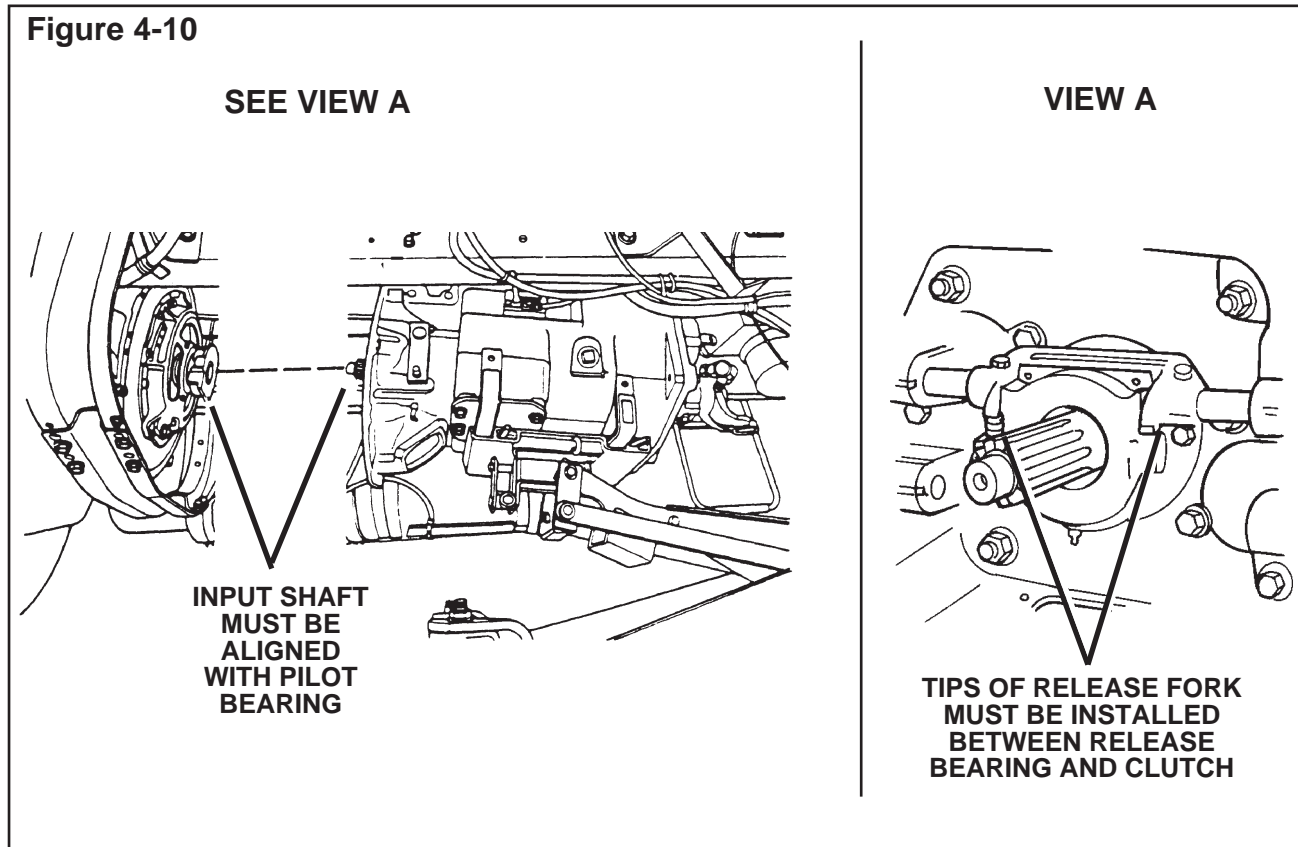
Figure 4-10



Removing and Installing the Transmission

- d. Push the transmission against the flywheel housing.
 16. Install the capscrews that fasten the clutch housing on the transmission to the flywheel housing. Tighten the capscrews to the specified torque and the sequence specified by the manufacturer of the vehicle.
 17. Align the transmission with the brackets on the frame. Install the fasteners that hold the transmission on the brackets. Tighten the fasteners to the torque specified by the manufacturer of the vehicle.
 18. Remove the transmission jack or lifting device from the transmission.
 19. If a hydraulic assist system is used for the clutch, install the slave cylinder in the bracket on the transmission. Connect the push rod to the release lever on the transmission. Connect the spring to the release lever.
 20. Connect the clutch linkage to the release lever on the transmission. Connect the spring to the release lever.
 21. Connect the air lines to the transmission.
 22. Connect the electrical connectors to the transmission.
 23. Connect the driveshaft to the output yoke on the transmission. Make sure the alignment marks on the output yoke and the driveshaft that were made during removal are aligned.
- Install and tighten the fasteners according to the specifications and the procedure of the manufacturer of the vehicle.
24. Connect the shift lever assembly to the transmission. If removed, install the shift tower assembly on the transmission.
 25. Lubricate the clutch housing, the cross shaft bushings and the release bearing housing. See the procedure of the manufacturer of the vehicle.
 26. Adjust the clutch and/or the linkage. See the procedure of the manufacturer of the vehicle.
-  **CAUTION**
Make sure the inspection cover on the clutch housing is used. If an inspection cover is not used, dirt and contaminants get into the clutch housing and damage the clutch.
27. Install the inspection cover. Install and tighten the capscrews. Tighten the capscrews to the specified torque of the manufacturer of the vehicle.
-  **CAUTION**
Use the specified oil. Do not use multi-viscosity or EP (Extreme Pressure) GL-5 gear oils. The wrong oil will damage the transmission.
28. Clean the area by the fill plug. Remove the fill plug from the transmission. Add the specified oil until the oil level is even with the bottom of the hole of the fill plug. **Figure 4-11.**

Section 4

Removing and Installing the Transmission

See "Transmission Oil Capacities" and "Transmission Oil Specifications" in Section 20, "Specifications".

Install and tighten the fill plug to 35-50 lb-ft (48-67 N.m). **T**

29. Operate the vehicle. Check for correct operation.

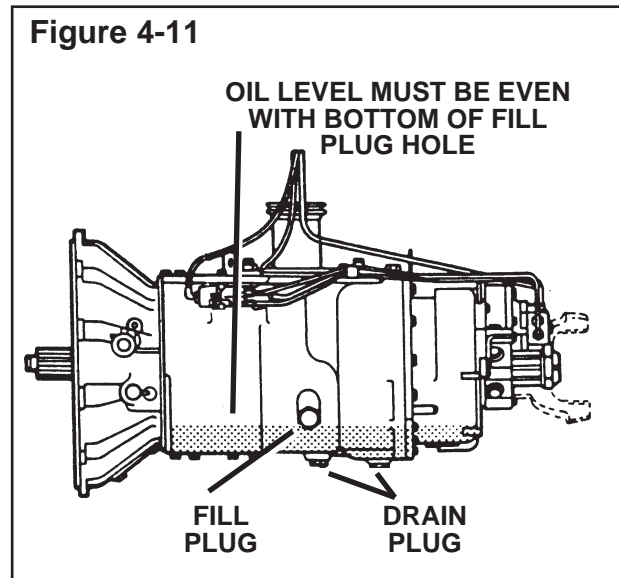

Section 5

Overhauling the Shift Lever and Tower Assembly



WARNING

To prevent serious eye injury, always wear safe eye protection when doing maintenance or service.

Disassembling the Aluminum Shift Lever and Tower Assembly

See Figure 5-1.

Figure 5-1

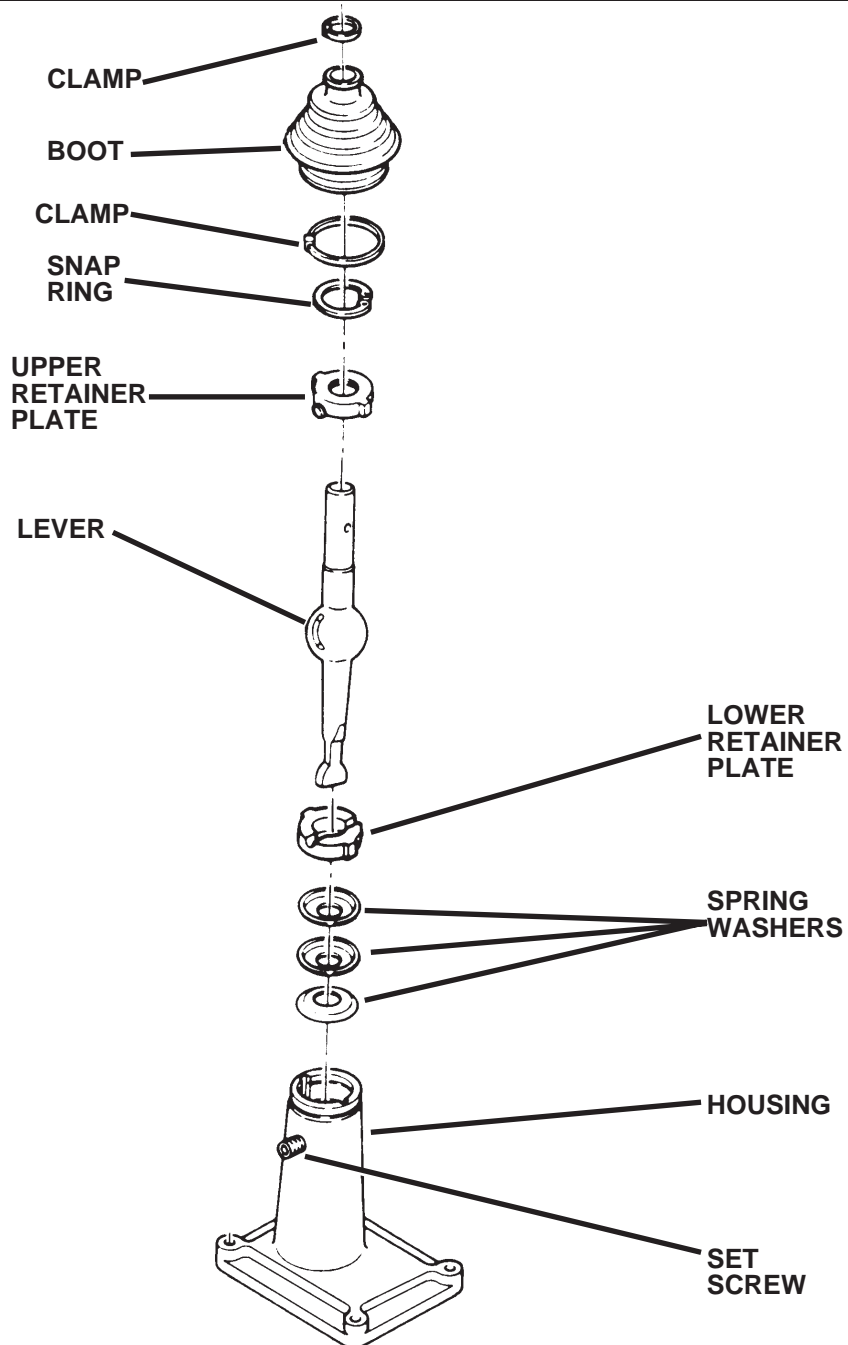

Section 5

Overhauling the Shift Lever and Tower Assembly

NOTE:

If an aluminum shift tower assembly is replaced, replace the entire assembly with a cast iron shift tower assembly. Make sure the gasket between the shift tower housing and the top cover housing is replaced. A different gasket is used on the aluminum than on the cast iron housing.

1. Remove the shift lever and tower assembly as described in Section 3, "In-Vehicle Service".
2. If necessary, separate the upper shift lever from the lower shift lever. See the following.
 - a. **If clips are used**, remove one clip. Remove the clip and pin assembly from the lever. Remove the bushings. **Figure 5-2**.
 - b. **If a bolt and nut is used**, remove the nut and the bolt.
 - c. Remove the upper shift lever from the lower shift lever. **Figure 5-2**.

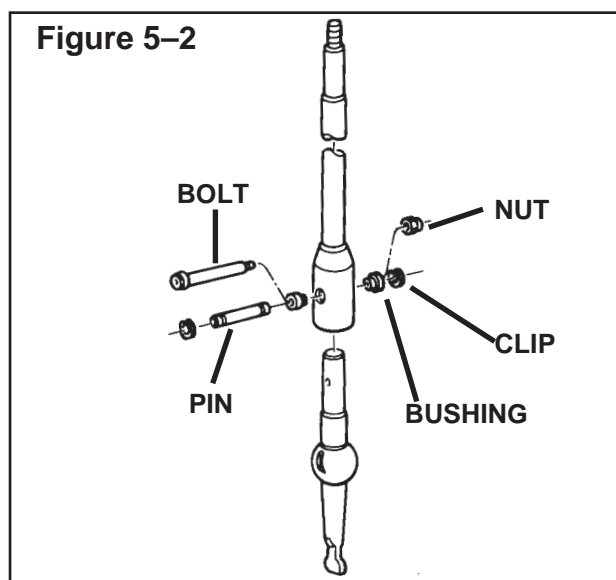

3. Remove the clamps that fasten the boot to the housing. Remove the boot from the housing and the lower shift lever.

4. Put the assembly in a vise with brass jaws. Make sure the inside of the housing is away from you.
5. Remove the snap ring that fastens the upper retainer plate and the lever in the housing. **Figure 5-3**.

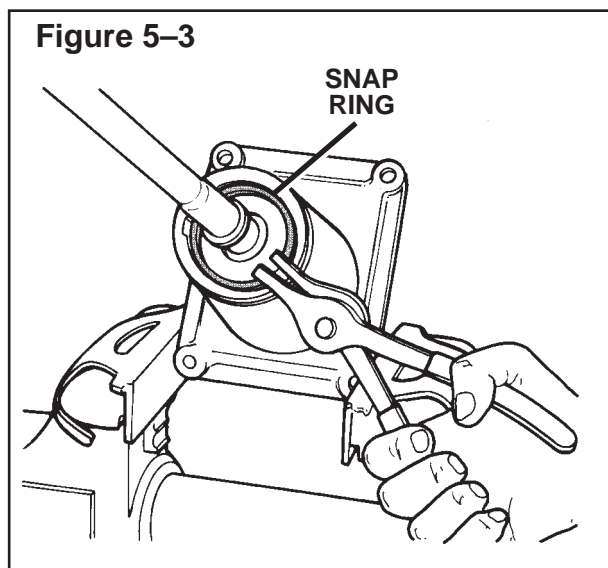

6. Remove the set screws from the side of the housing. Remove the lower retainer from the housing. **Figure 5-4**.

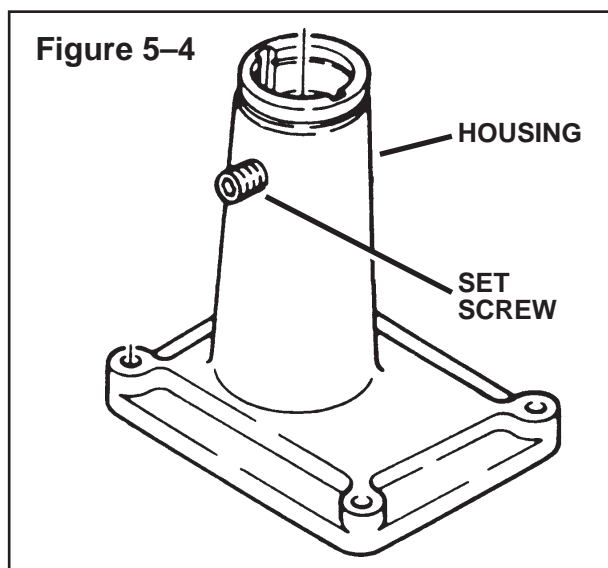

Section 5

Overhauling the Shift Lever and Tower Assembly

7. Lift on the lever to remove the lever and the upper retainer plate from the housing. **Figure 5-5.**

NOTE:

Two or three spring washers may be used in the housing. Make sure the same number of washers are installed.

8. Remove the spring washers from the housing. **Figure 5-6.**
9. Inspect all parts. See “Repairing or Replacing the Parts” in Section 1.

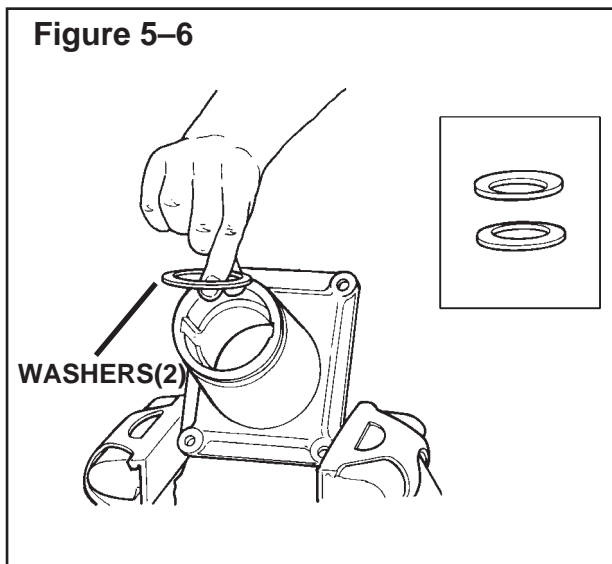
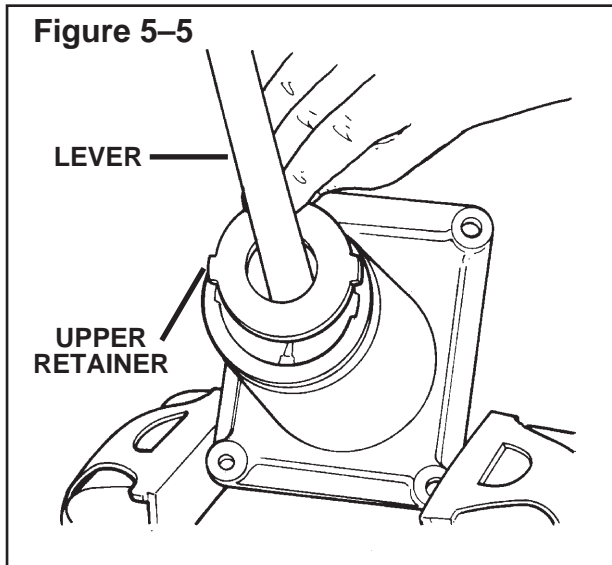

Assembling the Aluminum Gear Shift Lever and Tower Housing

See Figure 5-1.

NOTE:

If an aluminum housing is being replaced, replace the entire assembly with a cast iron shift tower housing.

1. Put the housing in a vise with brass jaws. Make sure the outside of the housing is toward you.

NOTE:

Two or three spring washers may be installed in the housing. Make sure the same number of washers are installed.

2. Install the spring washers in the bottom of the housing. Make sure the large ends of the washers touch and the bevels of the washers are installed away from each other as shown in **Figure 5-7.**

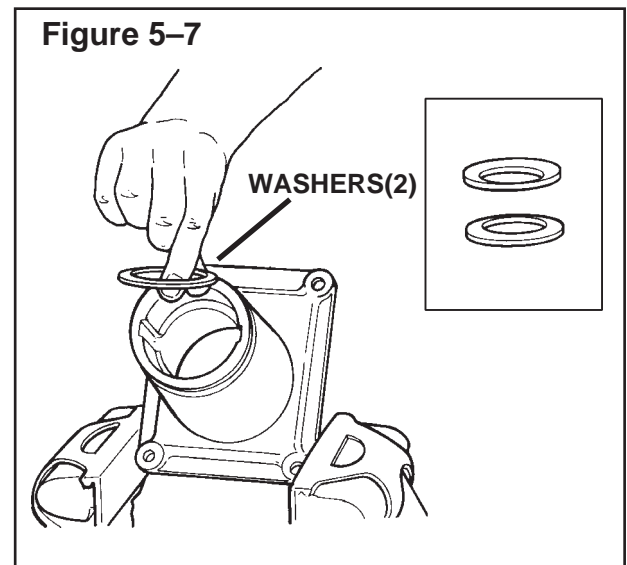

Section 5

Overhauling the Shift Lever and Tower Assembly

3. Install the lower retainer plate in the housing. Make sure the tabs of the retainer are in the slots in the housing.
4. Install the lever so that the slots in the lever are installed over the pins.
Figure 5–8.

5. Install the upper retainer plate over the lever and in the housing. Make sure the tabs on the plate are installed in the slots in the housing. On some housings, make sure the pins in the plate are aligned with the slots in the ball on the lever. **Figure 5–8.**

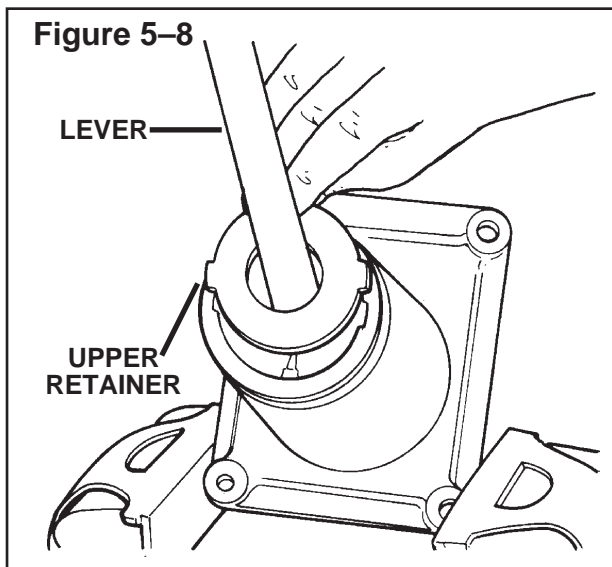

6. Install the snap ring that fastens the upper retainer plate and the lever in the housing. **Figure 5–9.**
7. Install and tighten the set screw that fastens the upper retainer plate in the housing. **Figure 5–10.**

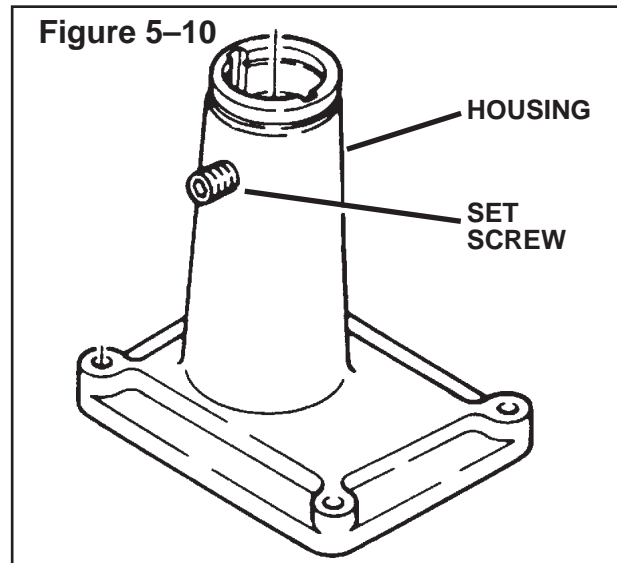
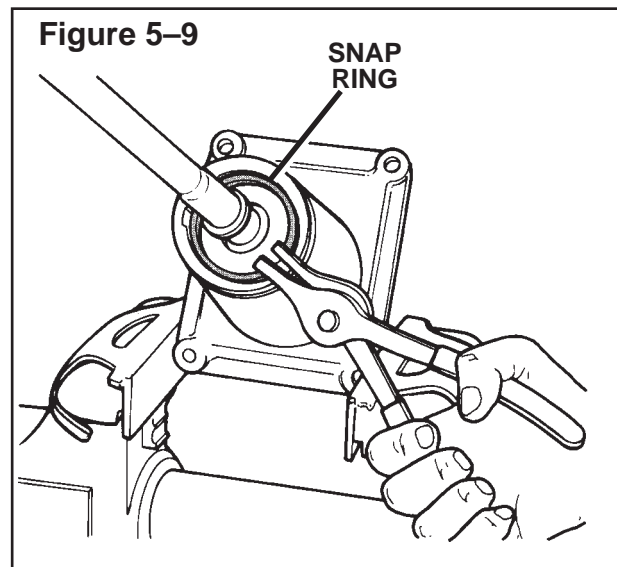

8. Install the boot on the housing. Make sure the lip on the boot is installed in the groove in the housing. Install the clamps or cable ties that fasten the boot to the lower lever and the housing. **Figure 5–11.**

Section 5

Overhauling the Shift Lever and Tower Assembly

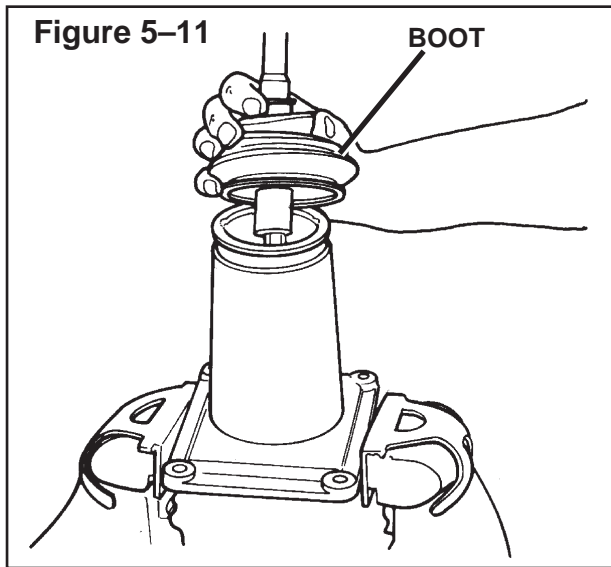

9. If removed, connect the upper shift lever assembly to the lower lever. See the following: **Figure 5-12**.
 - a. Install the upper shift lever assembly on the lower lever. Make sure the bores for the retainers are aligned.

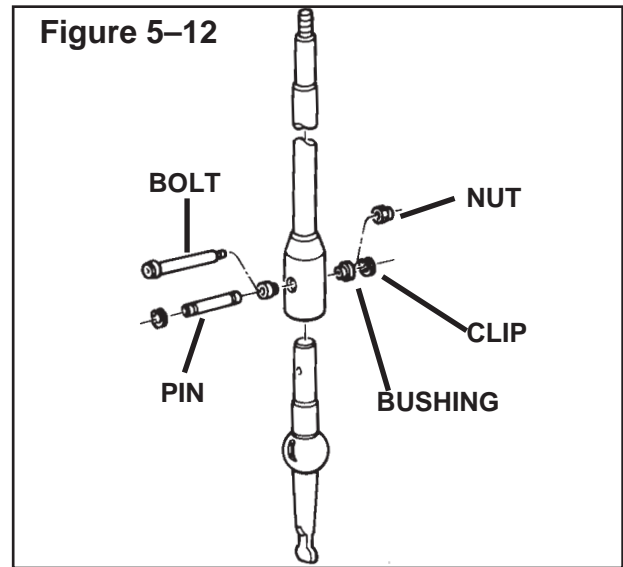

- b. If clips are used, install a bushing in each side. Install a clip on one end of the pin. Install the pin in the bores. Install the clip on the other end of the pin.
 - c. If a bolt and nut is used, install the bolt in the bores. Install and tighten the nut to 8-12 lb-ft (11-16 N.m).



Section 5

Overhauling the Shift Lever and Tower Assembly



WARNING

To prevent serious eye injury, always wear safe eye protection when doing maintenance or service.

Disassembling the Cast Iron Shift Lever and Tower Assembly

See Figure 5–13.

1. Remove the shift lever and tower assembly as described in Section 3, “In-Vehicle Service”.
2. If necessary, separate the upper shift lever from the lower shift lever. See the following.
 - a. **If clips are used**, remove one clip. Remove the clip and pin assembly from the lever. Remove the bushings. **Figure 5–14.**
 - b. **If a bolt and nut is used**, remove the nut and the bolt. **Figure 5–14.**
 - c. Remove the upper shift lever from the lower shift lever.
3. Remove the clamps that fasten the boot to the housing. Remove the boot from the housing and the shift lever.
4. Put the assembly in a vise with brass jaws. Make sure the inside of the housing is toward you.
5. Remove the spiral snap ring that fastens the spring, the spacer and the lower lever in the housing.

Figure 5–13

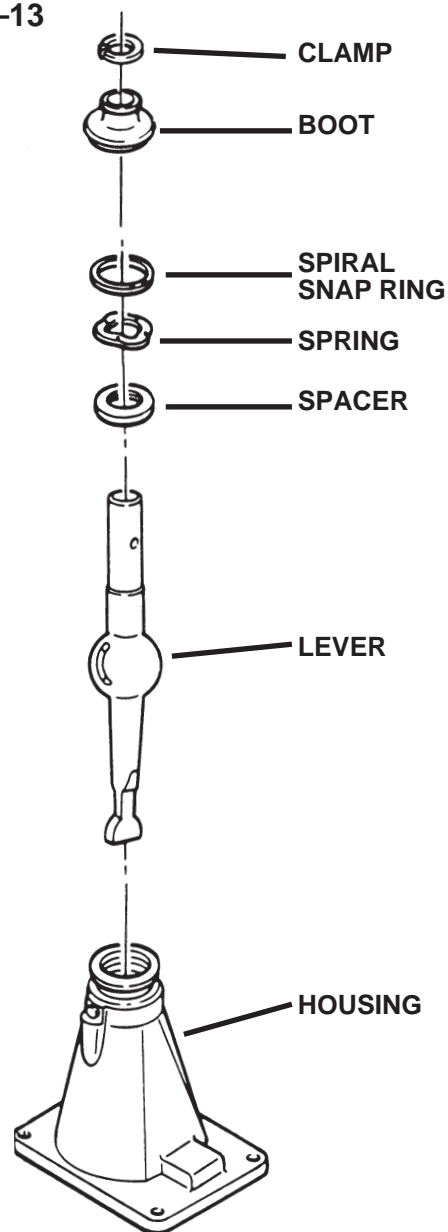

6. Lift on the lower lever to remove the lever. Remove the spring and the spacer from the lower lever.
7. Inspect all parts. See “Repairing or Replacing the Parts” in Section 1.

Overhauling the Shift Lever and Tower Assembly

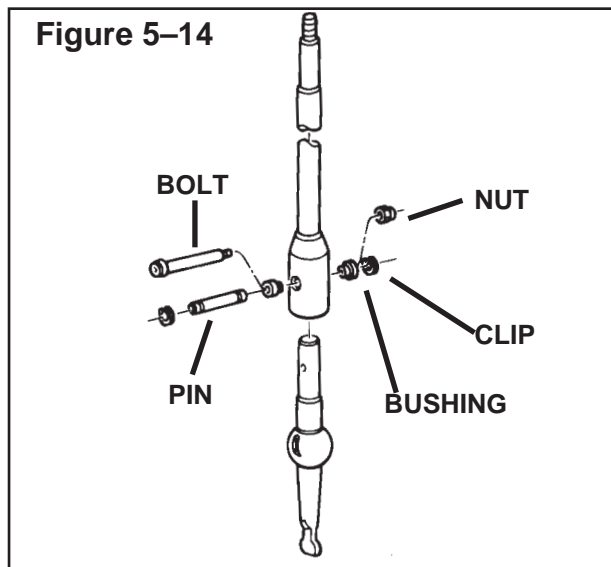

Assembling the Cast Iron Shift Lever and Tower Assembly

See Figure 5-13

1. Put the housing in a vise with brass jaws. Make sure the outside of the housing is toward you.
2. Install the lower lever in the housing. Make sure the slots on the ball of the lever are aligned with the pins in the housing.
3. Install the spacer over the lower lever. Install the assembly in the housing.
4. Install the spring over the lower lever in the housing.
5. Install the spiral snap ring over the lower lever in the housing. Make sure the snap ring is completely installed in the groove in the housing.
6. Install the boot on the housing. Make sure the lip on the boot is installed in the groove in the housing. Install new cable ties that fasten the boot to the housing.
7. If removed, connect the upper lever to the lower lever. See the following:
 - a. Install the upper lever of the lower lever. Make sure the bores for the retainers are aligned.
 - b. If clips are used, install a bushing in each side. Install a clip on one end of the pin. Install the pin in the bores. Install the clip on the other end of the pin.
 - c. If a bolt and nut is used, install the bolt in the bores. Install and tighten the nut to 8-12 lb-ft (11-16 N.m).



Section 6

Overhauling the Remote Control Assembly



WARNING

To prevent serious eye injury, always wear safe eye protection when doing maintenance or service.

Disassembling the Remote Control Assembly

Refer to Figure 6-1.

1. Remove the set screw that fastens the outer shift lever to the shaft. Remove the lever.
2. Remove and discard the two tie straps that fasten the boot to the housing. Remove the boot.
3. Remove the lockwire and the set screw that fasten the inner shift lever to the shaft. Remove the shaft and the inner shift lever.
4. Inspect the bushings in the housing. If worn or damaged, use a driver tool to remove the bushings.
5. If necessary, loosen the sockets and remove the adjusting rod.

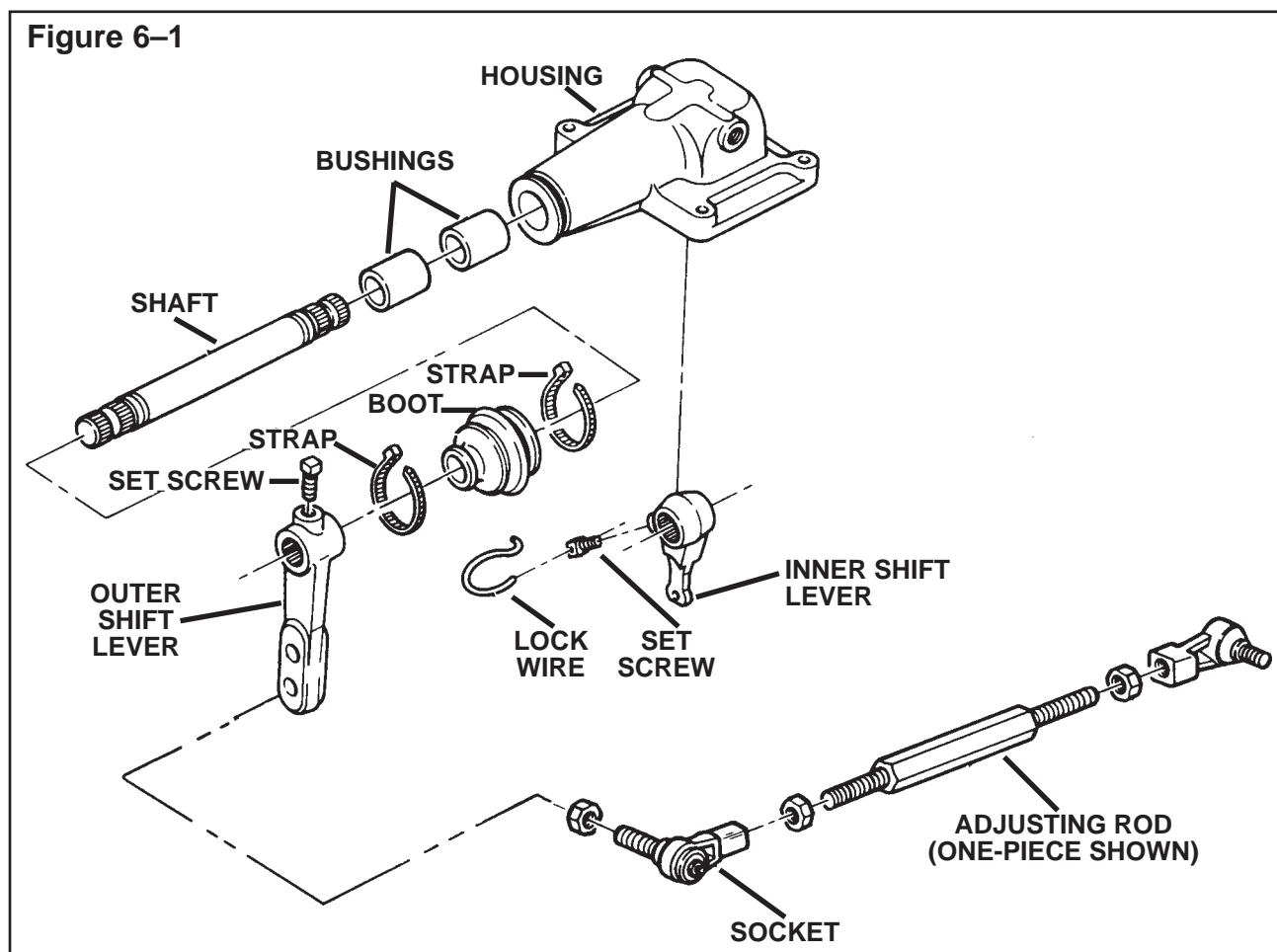

Section 6

Overhauling the Remote Control Assembly

Assembling the Remote Control Assembly

1. Do the following to the set screws that fasten the levers to the shaft.
 - a. Clean the threads of the set screws with Loctite® Safety Solvent (Meritor part number 2297-P-6412) or equivalent. Make sure all dirt is removed from the threads.

NOTE:

See the specifications of the sealant manufacturer for the “cure” time.

- b. Apply Loctite® #242 (Meritor part number 2297-V-2430) or equivalent to the threads of the set screws.
2. Lubricate the bushings with a lithium 12-hydroxy stearate grease such as Multi-Purpose grease, Meritor specification O-617-A or equivalent.
3. If removed install the adjusting rod assembly in the housing. Tighten the socket to 35-50 lb-ft (47-68 N.m). **T**
4. If removed, use a driver tool to install the bushings.

5. Fill the area between the bushings with multi-purpose grease.
6. Put the inner shift lever in position in the housing. Install the shaft in the lever. Install and tighten the set screw to 32-40 lb-ft (44-54 N.m). Install the lockwire. **T**
7. Install the boot over the shaft and on the housing. Install new tie straps.
8. Put the outer shift lever on the shaft. Make sure the outer shaft lever is aligned with the inner shaft lever. Install and tighten the set screw to 32-40 lb-ft (44-54 N.m). **Figure 6-2.** **T**

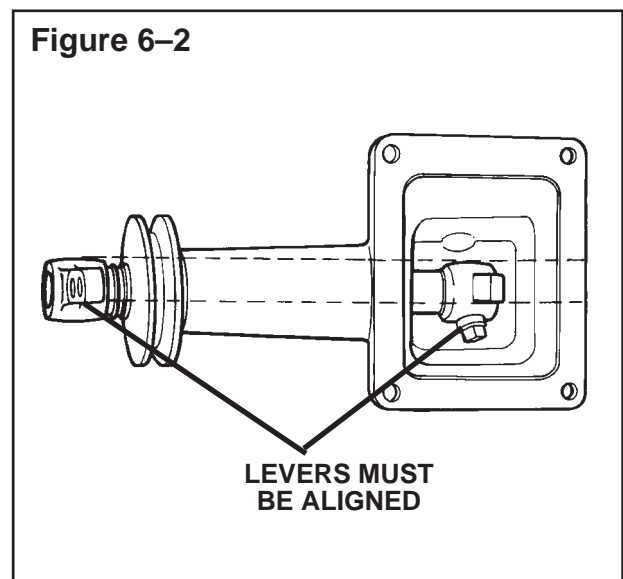

Section 7

Removing and Installing the Top Cover Assembly



WARNING

To prevent serious eye injury, always wear safe eye protection when doing maintenance or service.

Removing the Top Cover Assembly

NOTE:

Four different top cover assemblies are available. See Figure 7-1.

- *Standard position top cover with a standard shift pattern.*
- *Standard position top cover with an "x" shift pattern.*
- *Forward position top cover with a standard shift pattern.*

- *Forward position top cover with an "X" shift pattern.*

Standard position top covers have the detent balls and springs under the shift lever housing.

Forward position covers have the detent springs and balls under a plate behind the shift lever housing.

Top covers with an "X" shift pattern have a stud and a nut that fastens the rocking lever assembly to the top cover.

1. Shift the transmission into the **NEUTRAL** position.
2. Remove the transmission (if necessary) and the shift lever and tower assembly as described in Section 3, "In-Vehicle Service".

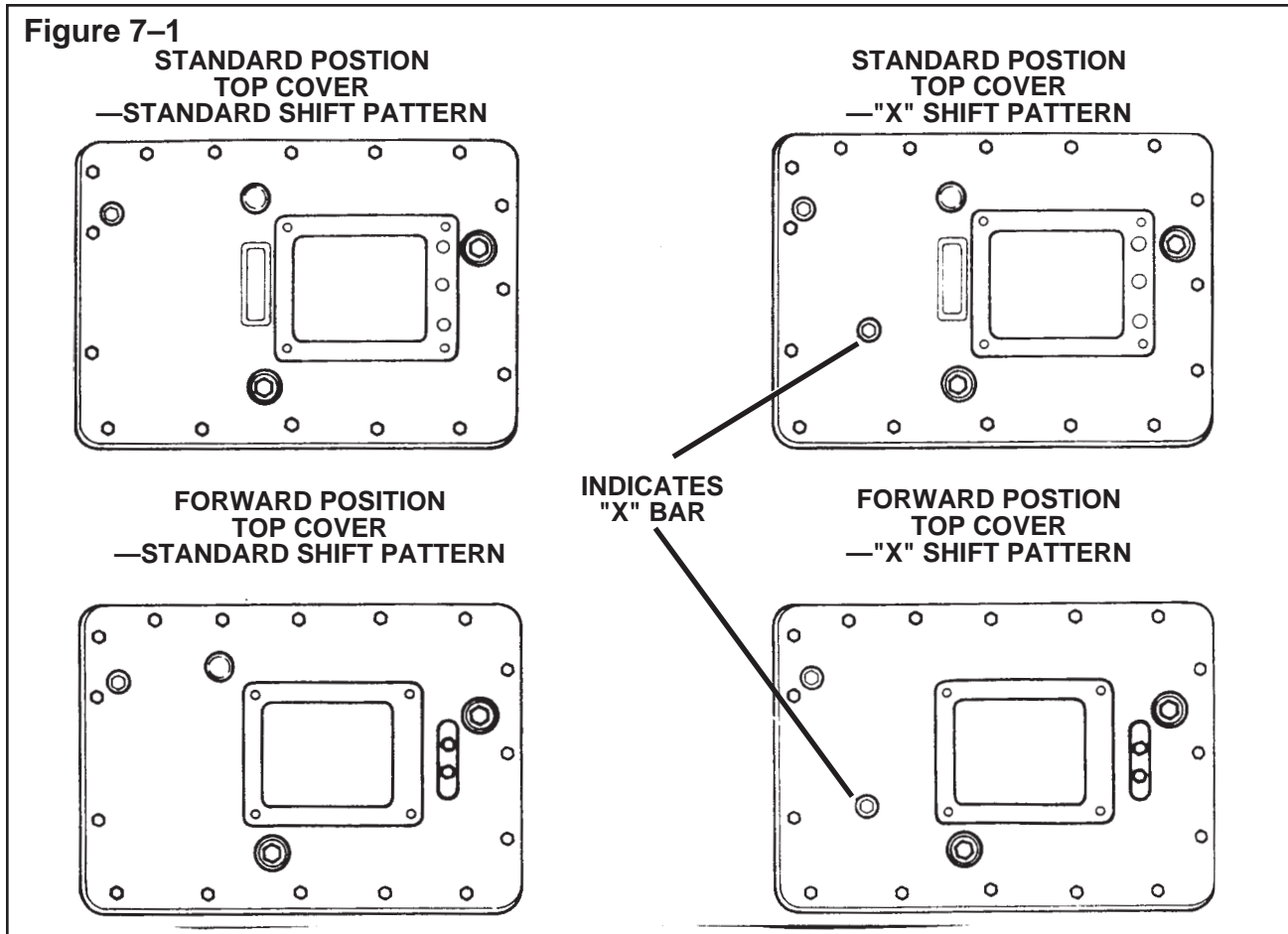

Removing and Installing the Top Cover Assembly

NOTE:

If a heavy-duty detent spring is used, the spring (different color) is in the bore on the slave valve side of the transmission.

3. Remove the three detent springs from the top cover from the holes in the top cover. **Figure 7-2.**
4. Use a magnet to remove a detent ball from the each of the three holes. **Figure 7-2.**
5. Remove the mounting capscrews and washers from the top cover.

! **CAUTION**

Use a rubber mallet or “dead blow” hammer to separate the top cover from the transmission case. Do not use pry bars or screwdrivers to separate the cover from the case. Pry bars or screwdrivers may damage the cover and case mounting surfaces. If the cover is still difficult to remove, remove the slave valve and the interlock pin from the main case.

6. Remove the top cover from the transmission case. **Figure 7-3.**
7. Use a scraper to remove the sealant material from the top cover and the transmission case.

Figure 7-2

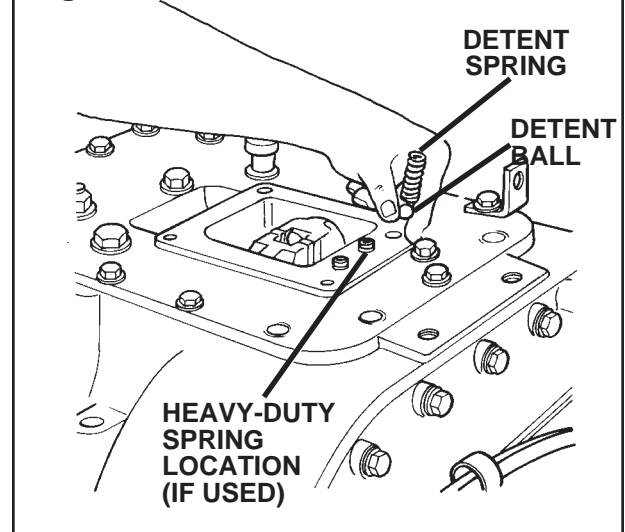
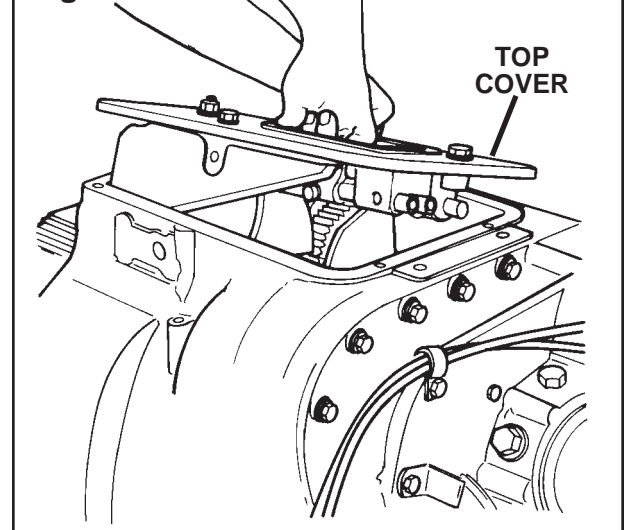

Figure 7-3



Section 7

Removing and Installing the Top Cover Assembly

Installing the Top Cover Assembly

1. Inspect the tips of the forks. If the tips of the forks are worn or damaged, replace the forks.

Inspect the shift sleeves. If the sleeves are worn or damaged, replace the sleeves.

To replace the fork or the sleeve, see Section 8, "Overhauling the Top Cover".

2. Inspect the set screws, if the set screws are loose, see the following:
 - a. Clean the threads of the set screws. Make sure all dirt is removed from the threads.

NOTE:

See the specifications of the sealant manufacturer for the "cure" time.

- b. Apply Loctite® #242 (Meritor Part Number (2297-V-5430) or equivalent to the threads of the capscrews
 - c. Tighten the capscrews to the torque in the "Torque Specifications Chart".
3. Inspect the lockwire. If the lockwire is missing or damaged, see the following:
 - a. Install the new lockwire.
 - b. Bend the wire towards the capscrew.
 - c. Twist the wire at least once between the parts. On the 1-2 sleeve and fork assembly, the wire can be wrapped around the shaft.

4. Make sure the transmission is in the **NEUTRAL** position.
5. Use Loctite® Master Gasket Sealant®, #5699 (Meritor Part Number 2297-A-7021) and a sealant dispenser, to put a new 1/8 inch (2 mm) sealant pattern for the top cover on the case. See "Gasket Sealant" in Section 1. **Figure 7-4.**

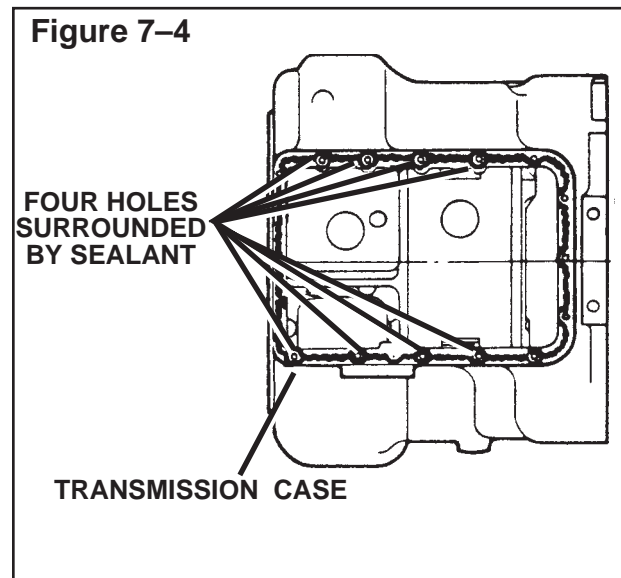

NOTE:

If the top cover is difficult to install, remove the slave valve and the interlock pin from the main case.

6. Install the top cover. Make sure the cover is in the **NEUTRAL** position. Make sure the forks of the cover engage the collars in the transmission case. **Figure 7-5.**

Section 7

Removing and Installing the Top Cover Assembly

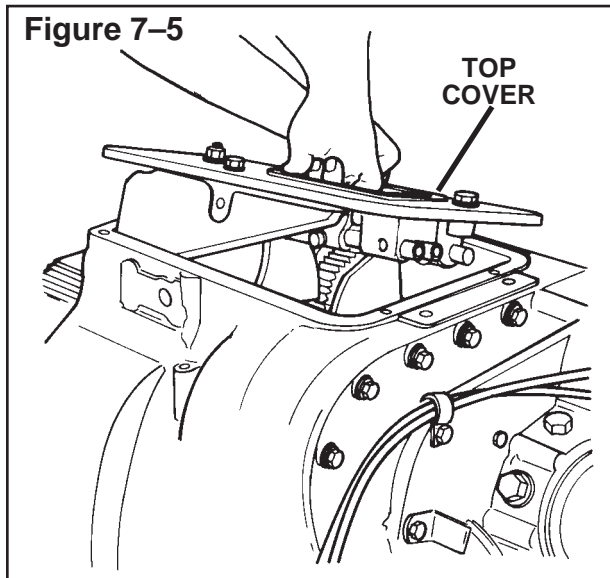

7. Install the mounting capscrews and washers for the top cover. Tighten the capscrews to 25-35 lb-ft (34-47 N.m).



8. Install a detent ball in each of the three holes in the top cover. **Figure 7-6.**

NOTE:

Replace the detent springs as a set. Use the “yellow” spring (Meritor part number 2258-D-1278) in all the holes.

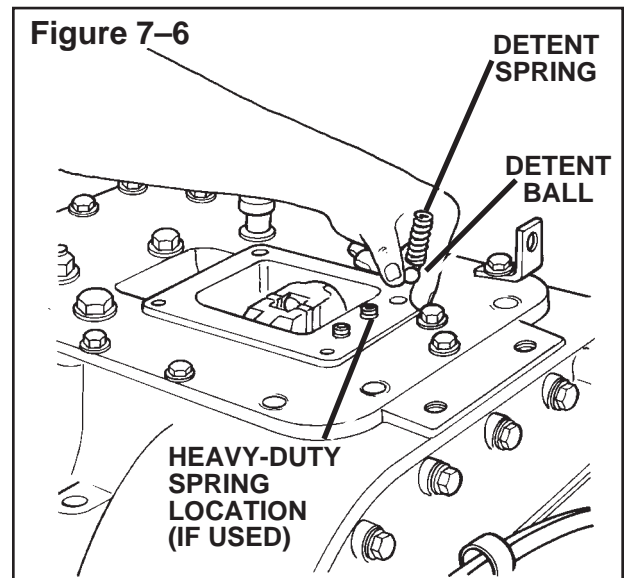

NOTE:

If a heavy-duty detent spring is used, install the spring (different color) in the bore on the slave valve side of the transmission.

9. Install a spring on top of each detent ball in the holes in the top cover. **Figure 7-6.**

Disassembling the Standard and Forward Position Top Cover Assembly

See Figures 8-1 and 8-2.

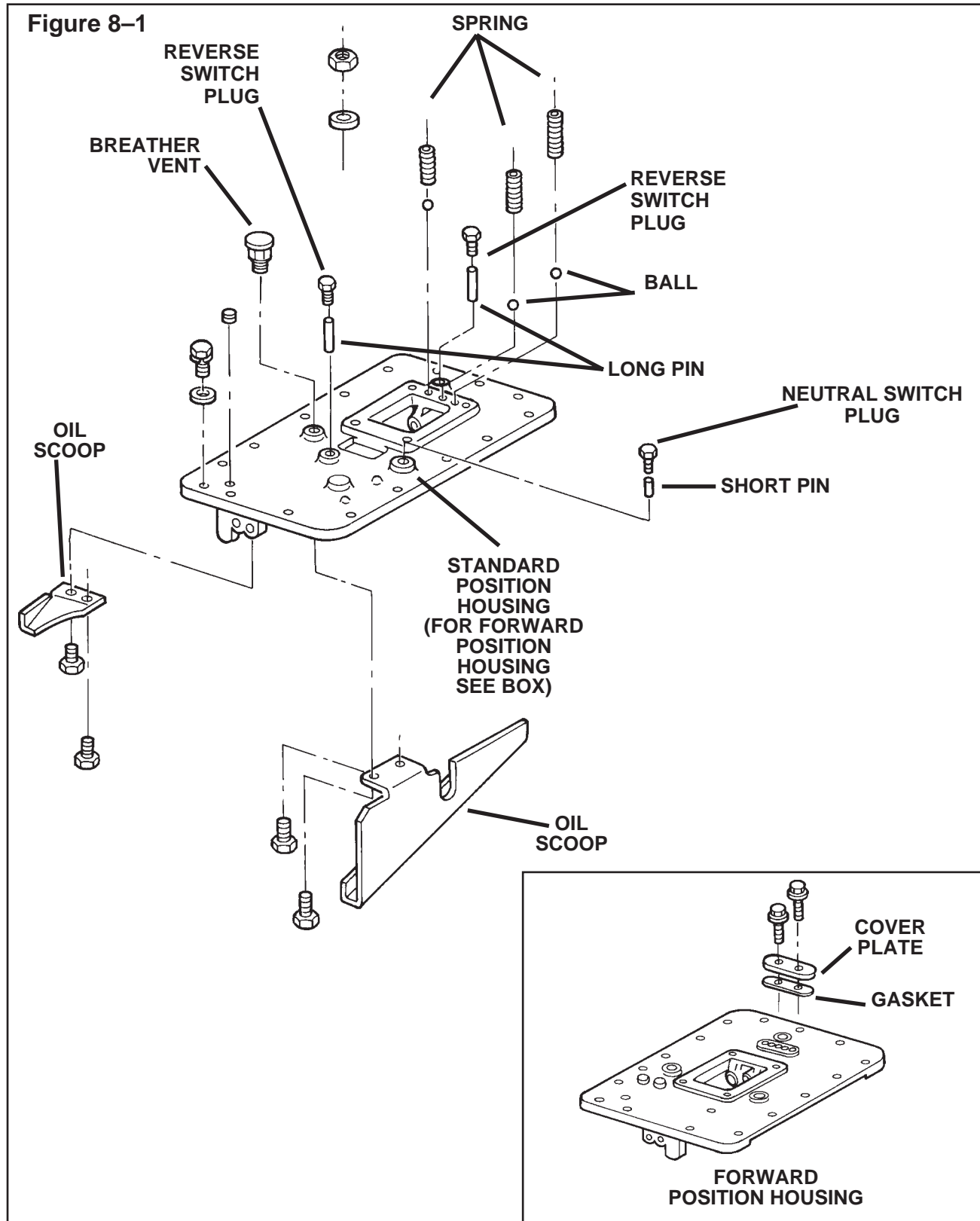

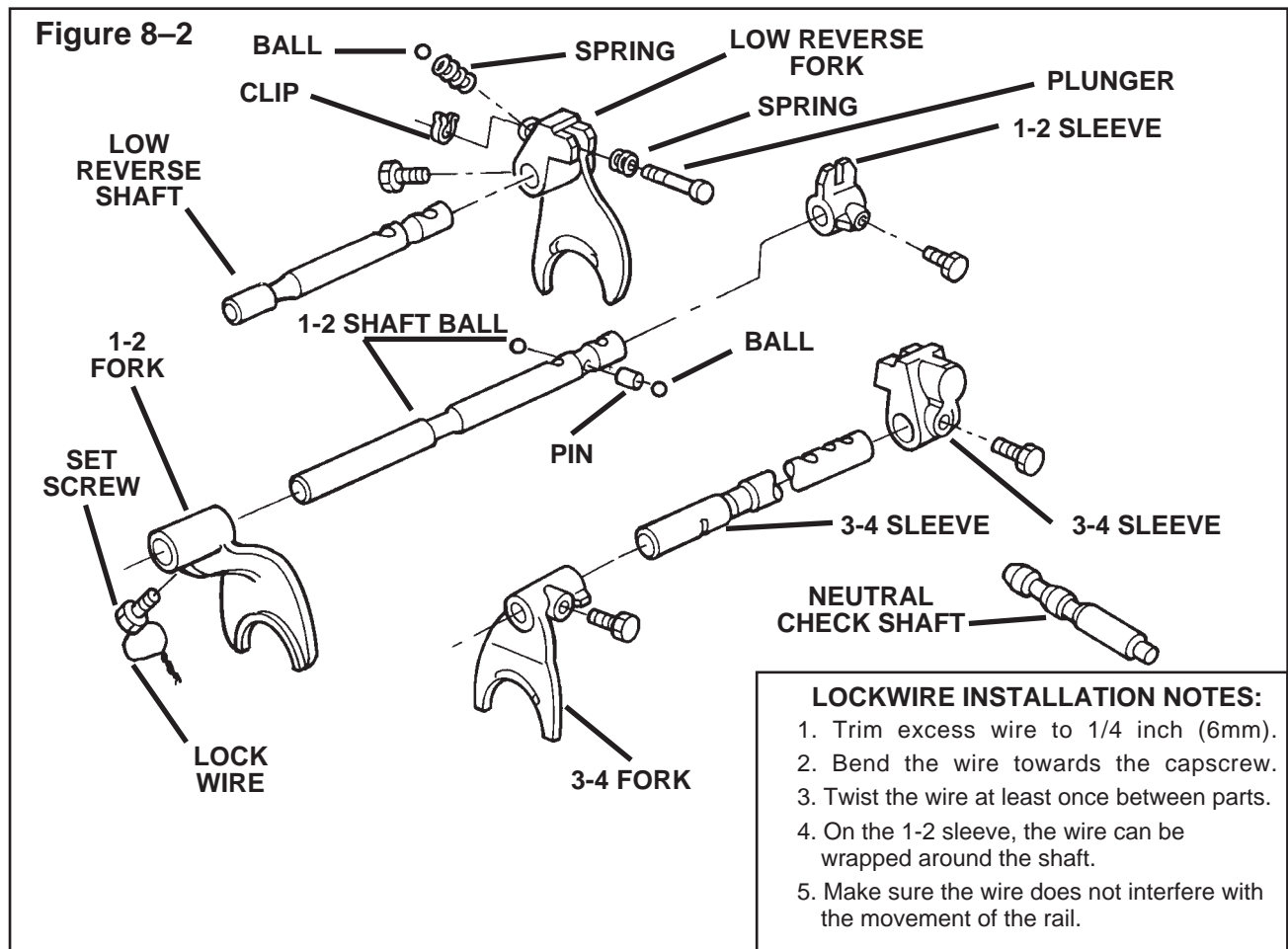

WARNING
To prevent serious eye injury, always wear safe eye protection when doing maintenance or service.

NOTE:
The standard position top cover and the forward position top cover use different housings. The forward position housing uses a plate and a gasket installed over the detent balls and springs.

1. Remove the top cover from the transmission case as described in this section. Make sure the top cover is in the **NEUTRAL** position. **Figure 8-3.**

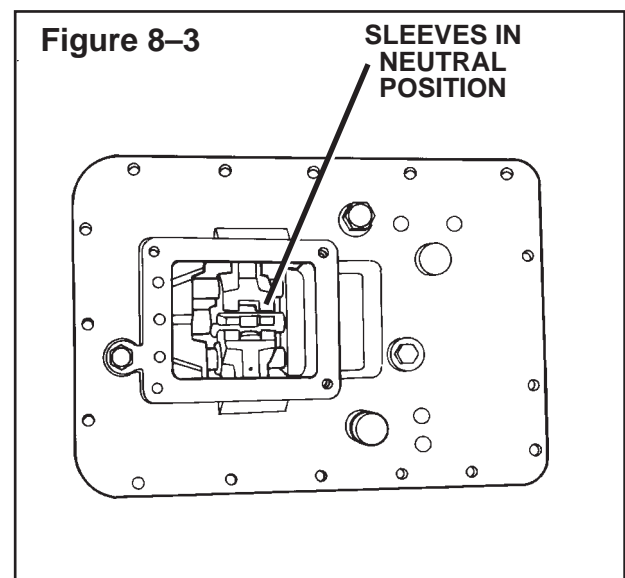

Section 8 Overhauling the Top Cover Assembly

Standard Pattern Top Cover

2. On forward top covers, remove the capscrews that fasten the spring cover plate (if installed) to the top cover. Remove the plate and the gasket.

NOTE:

If a heavy-duty detent spring is used, the spring (different color), is in the bore on the slave valve side of the transmission.

3. If installed, remove the three detent springs and balls from the top of the housing. **Figure 8-4.**

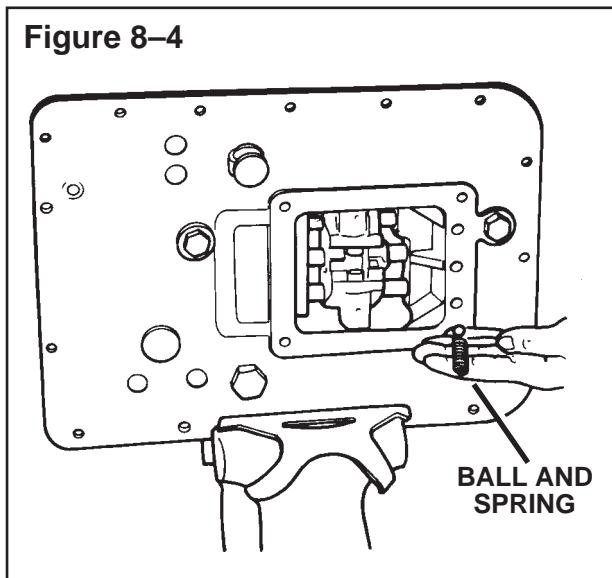

CAUTION

Do not damage the machined surface of the case. If the surface is damaged, the case will leak

4. Put the top cover on the bench so that the forks are toward you or in a vise with brass protectors on the jaws.
5. Remove the capscrews that fasten the large and the small oil scoops to the cover. **Figure 8-5.**
6. Cut and remove the lock wire on the fork, sleeve and set screw assembly. **Figure 8-5.**

Figure 8-5

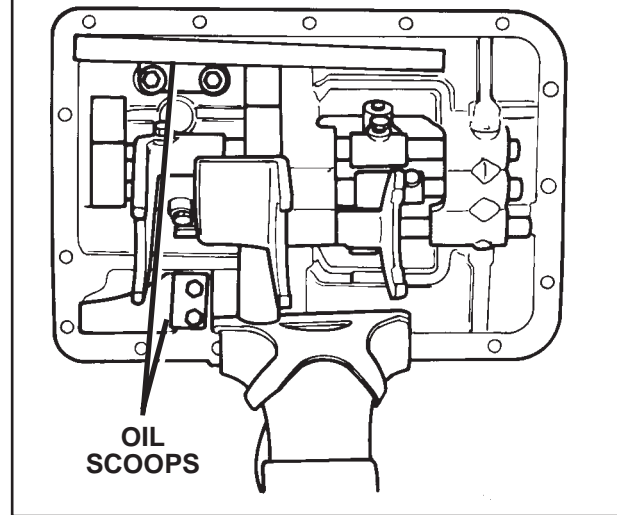

7. Remove the set screws that fasten the shift fork and sleeve assembly to the shift shafts. **Figure 8-6.**

Figure 8-6

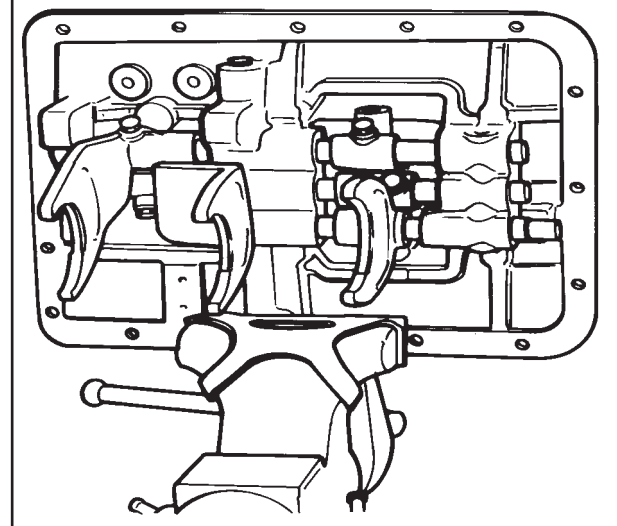

8. Remove the 3-4 shift shaft from the housing. Remove the 3-4 shift sleeve. Remove the 3-4 shift fork. **Figure 8-7.**

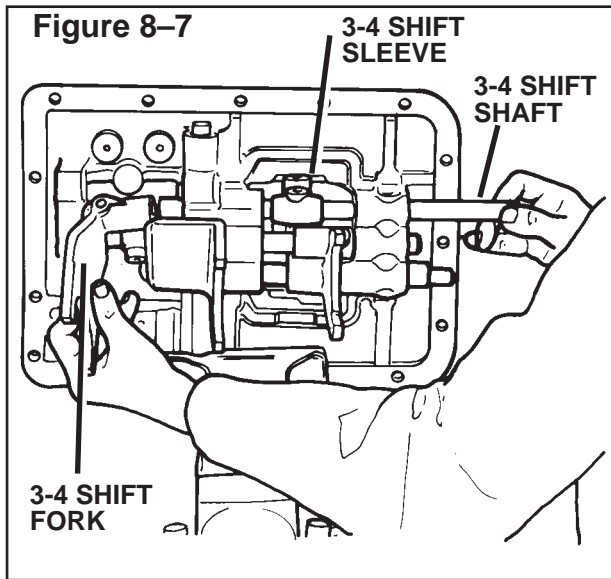

9. *On Design Level 1, nine-speed transmissions, if necessary, disassemble the 3-4 shift sleeve. Remove the clip that fastens the 3-4 plunger in the housing. Remove the plunger. Figure 8-8.*

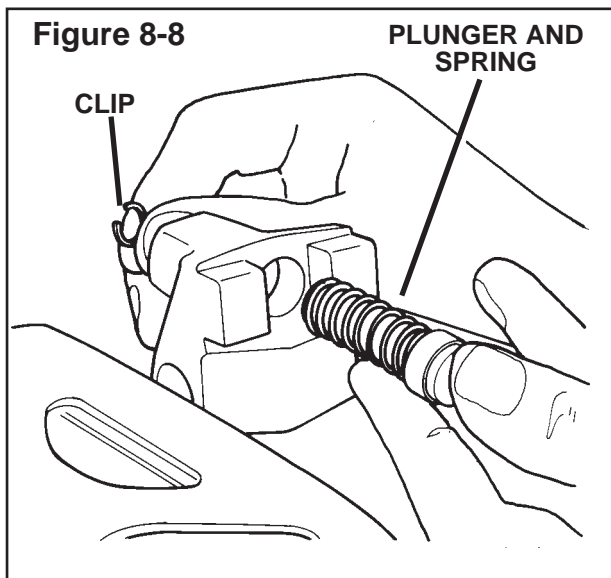

10. Remove the interlock ball from the bottom of the top bore of the first set of bores at the rear of the housing. Figure 8-9.

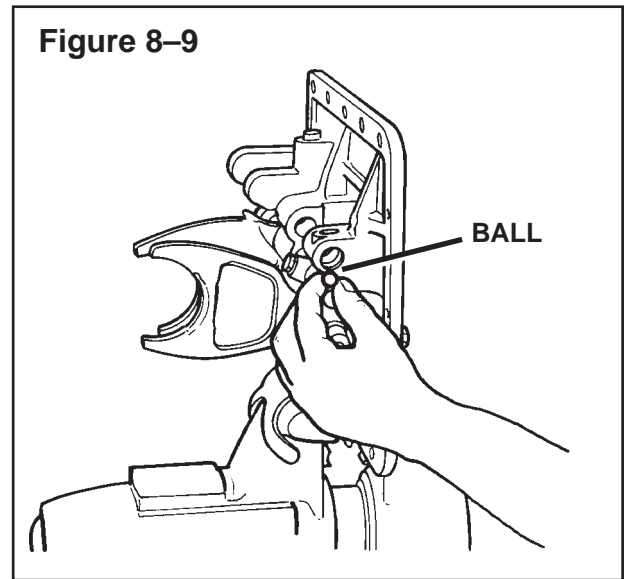

11. Remove the 1-2 shift shaft, the 1-2 shift fork and the 1-2 shift sleeve from the housing. Remove the pin interlock from the end of the 1-2 shift shaft. Figure 8-10.

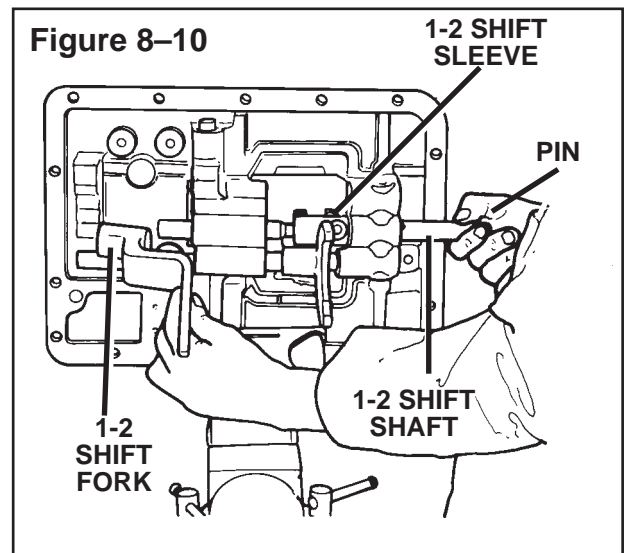

12. Remove the interlock ball from the bottom of the middle bore in the first set of bores in the housing. Figure 8-11.

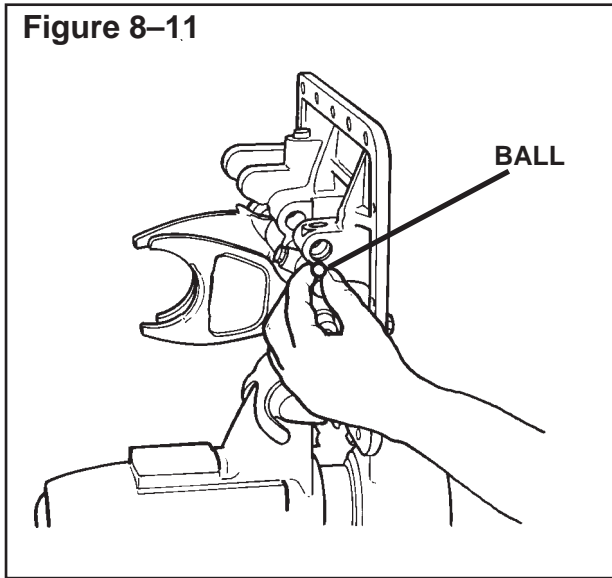

13. Remove the neutral check shaft from the top cover. **Figure 8-12.**

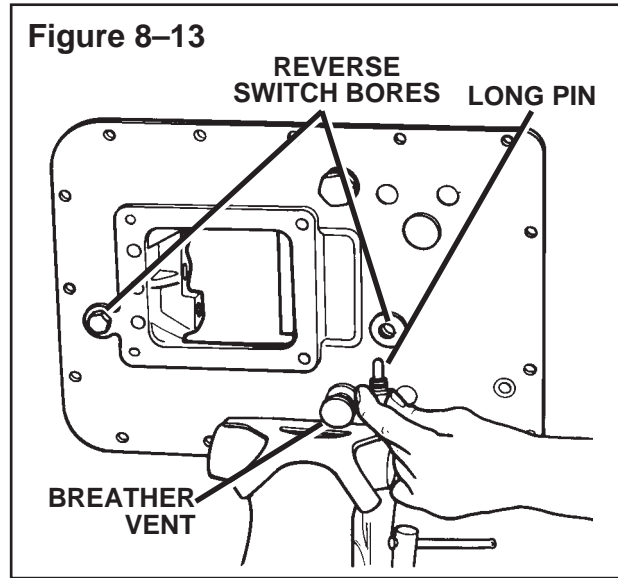

15. Remove the low-reverse shift shaft. Remove the low-reverse shift sleeve and fork assembly. **Figure 8-14.**

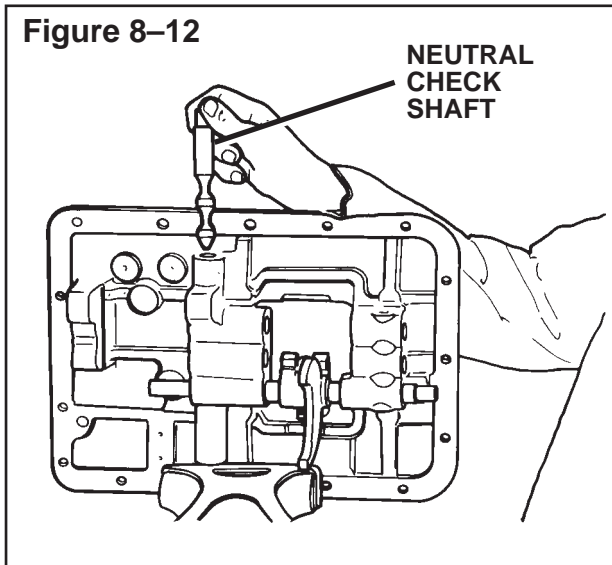

NOTE:
 On standard position top covers, one or two reverse switches may be used. On forward position top covers, one reverse switch is used.

14. Remove the reverse switch(es) or plugs from the top of the housing. Remove the long pin(s) from each bore. **Figure 8-13.**

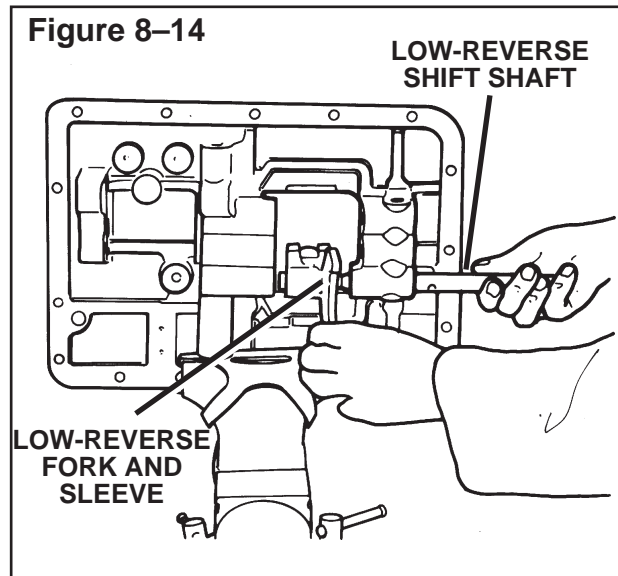

16. If necessary, disassemble the low-reverse sleeve and fork assembly. Remove the clip that fastens the plunger in the housing. Remove the plunger and the spring. Remove the spring and the ball from the bore next to the plunger bore. **Figure 8-15.**

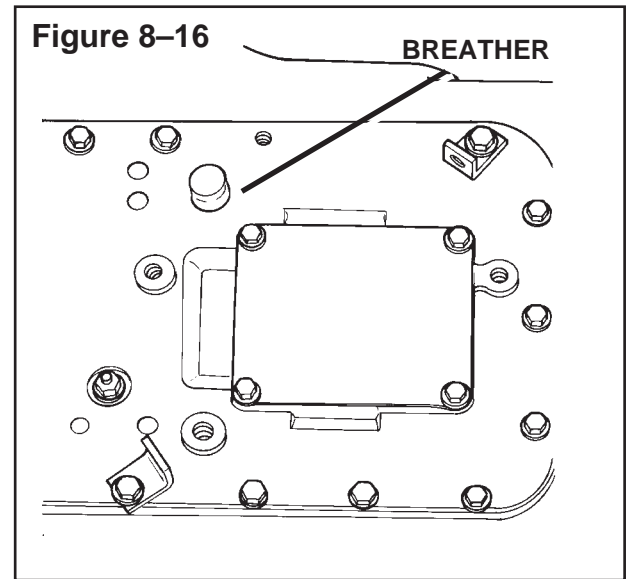
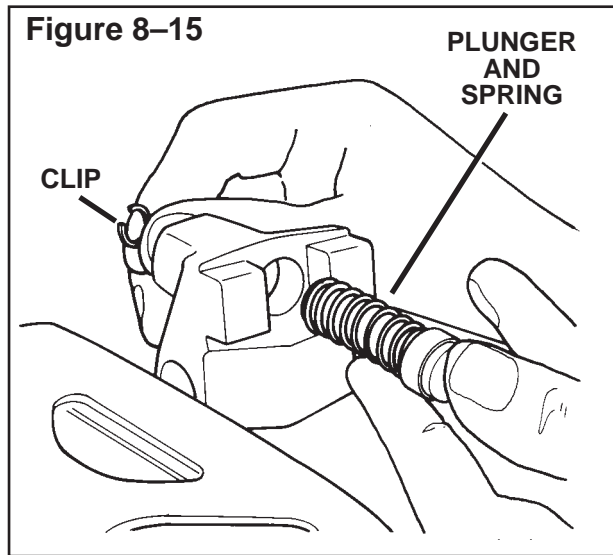

17. If necessary, remove the breather from the top of the cover. **Figure 8-16.**
18. Remove the neutral safety switch or plug. Remove the short pin from the bore. **Figure 8-17.**
19. Inspect all parts. See Section 1, "Repairing and Replacing the Parts".

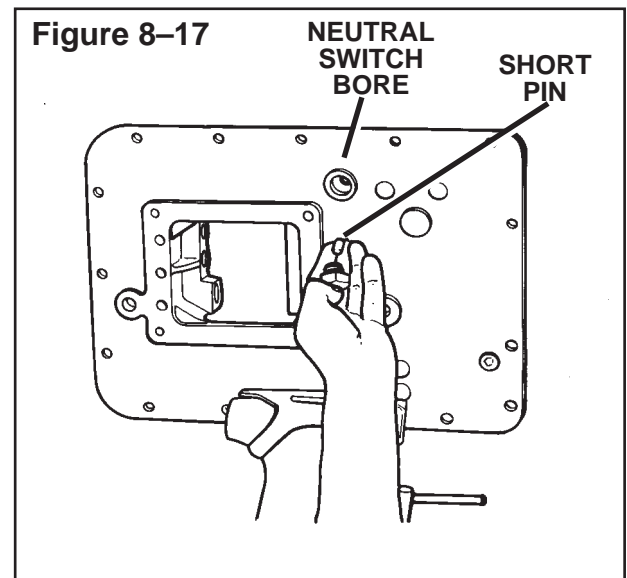

Assembling the Standard and Forward Position Top Cover Assembly

See Figures 8–1 and 8–2.

NOTE:

The standard position and the forward position top covers use different housing. The forward housing also uses a plate and a gasket installed over the detent balls and springs.

1. Lubricate all the parts of the top cover with the oil that is used in the transmission.
2. Do the following to the set screws that fasten the shift sleeves and/or forks to the shift shafts and the capscrews for the oil scoops.
 - a. Clean the threads of the fasteners with Loctite® Safety Solvent #755 (Meritor part number 2297-P-6412) or equivalent. Make sure all dirt is removed from the threads.

NOTE:

See the specifications of the sealant manufacturer for the "cure" time.

- b. Apply Loctite® #242 (Meritor part number 2297-V-5430) or equivalent to the threads of the fasteners.
3. Install the top cover in a vise with brass jaws. Make sure the low-reverse bore holes are toward the bottom of the vise.
 4. Install the short pin in the bore for the neutral safety switch. Install the switch or plug and tighten to 35-50 lb-ft (48-67 N.m). **Figure 8–18.** 

5. Install the breather vent in the top cover. Tighten to 15-20 lb-ft (21-27 N.m). **Figure 8–18.** 

NOTE:

On standard position top covers, one or two reverse switches may be used. On forward position top covers, one reverse switch is used.

6. Install the larger pin(s) in the bore(s) for the reverse switch. Install the switches or plugs and tighten to 35-50 lb-ft (48-67 N.m). **Figure 8–18.** 

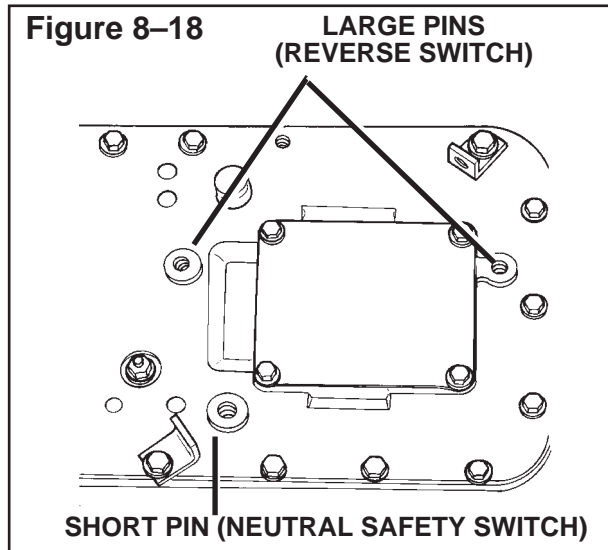

7. If disassembled, install the plunger assembly in the low-reverse shift 7fork. See the following. **Figure 8–19.**
 - a. Put the fork in a vise with brass jaws.
 - b. Install the spring and the ball in the bore next to the plunger.
 - c. Install the plunger and the spring in the bore of the fork.
 - d. Install the snap ring that holds the assembly in the fork.

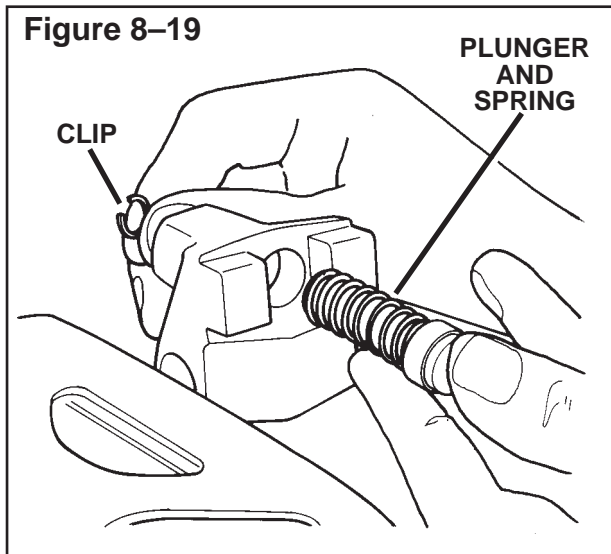

8. Assemble the low-reverse shift shaft assembly. See the following procedure.

NOTE:

The low-reverse shaft is the shortest of the three shafts.

- a. Put the low-reverse shift shaft in the bottom bore of the housing. Make sure the boss on the end of the shaft is toward the rear of the housing. Make sure the detent grooves in the rail are aligned with the detent ball holes in the housing. **Figure 8-20.**
- b. Put the low-reverse shift fork assembly in the top cover so that the plunger of the fork is toward you. Make sure the bore of the fork and sleeve assembly is aligned with the bore in the housing. **Figure 8-20.**
- c. Push the shift shaft through the low-reverse sleeve and fork assembly.
- d. Push the shaft through the assembly until the holes in the fork and shaft are aligned.

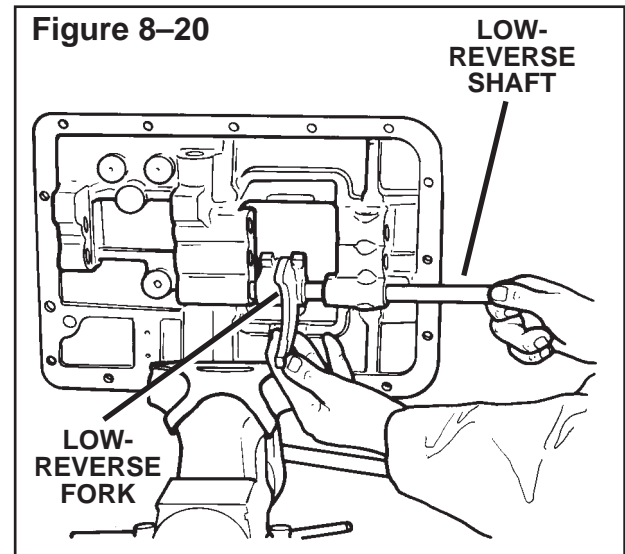

CAUTION

After the setscrews with the Loctite® sealant (see step 2) are tightened to the specified torque, do not loosen or tighten. If loosened or tightened, the set screws must be removed, cleaned and new sealant applied or the set screws may loosen during operation.

- e. Install the set screw with the Loctite® sealant (see step 2) that fasten the fork in position on the shaft. Tighten the set screw to 35-45 lb-ft (47-54 N.m). **Figure 8-21.**

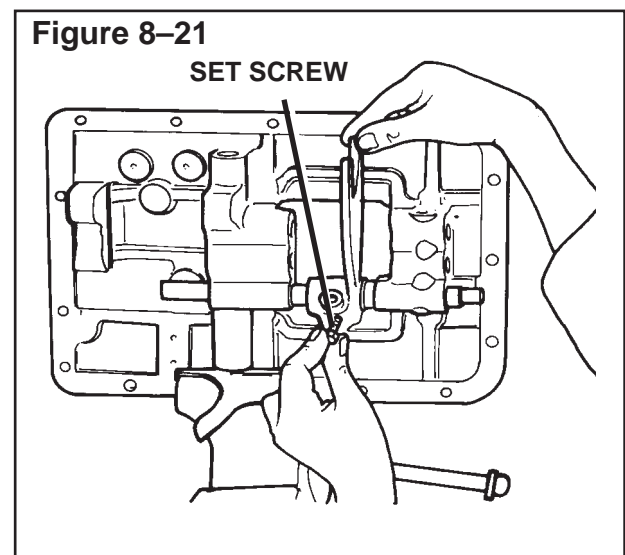

Section 8 Overhauling the Top Cover Assembly

Standard Pattern Top Cover

- f. Install the lock wire in the holes in the capscrew and the fork and sleeve assembly. **Figure 8-21.**
9. Install the neutral check shaft in the bore on the top of the housing. Make sure the round end of the shaft is installed toward the low-reverse shift shaft. Make sure the end of the neutral check shaft touches the slot in the Low/Reverse shaft. **Figure 8-22.**

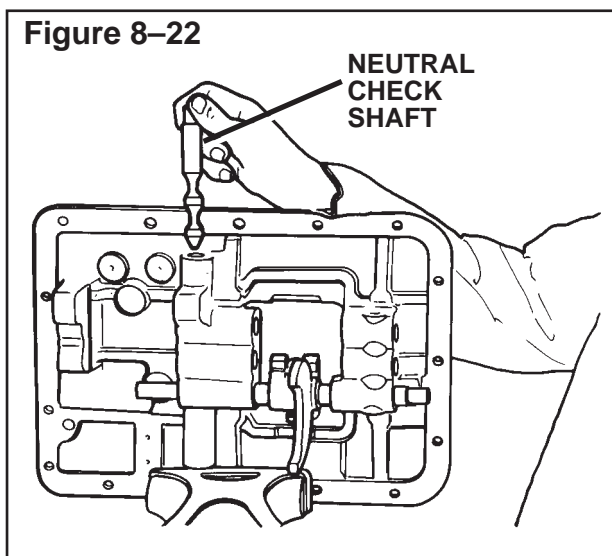

10. Put the large interlock ball in the bottom of the middle bore of the first set of bores on the rear of the housing. **Figure 8-23.**

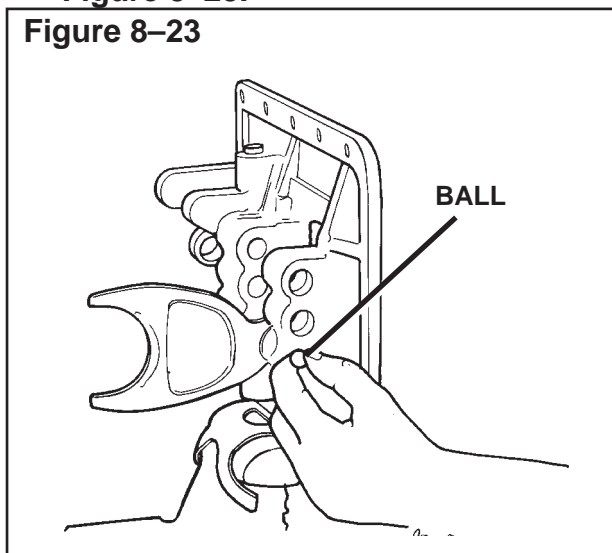

11. Assemble the 1-2 shift rail assembly. See the following procedure.

NOTE:

The 1-2 shift rail is the same size as the 3-4 shift rail and has a hole drilled through the rail.

NOTE:

Move the low-reverse shift shaft assembly so that the interlock ball is completely installed in the bore. Move the low-reverse shaft assembly so that the 1-2 rail can be installed.

- a. Put the 1-2 shift shaft in the middle bore of the housing. Make sure the identification on the end of the shaft is toward the front of the housing. Make sure the detent grooves in the shaft are aligned with the detent ball holes in the housing. **Figure 8-24.**
- b. Put the interlock pin in the hole drilled in the side of the 1-2 shift shaft. **Figure 8-24.**

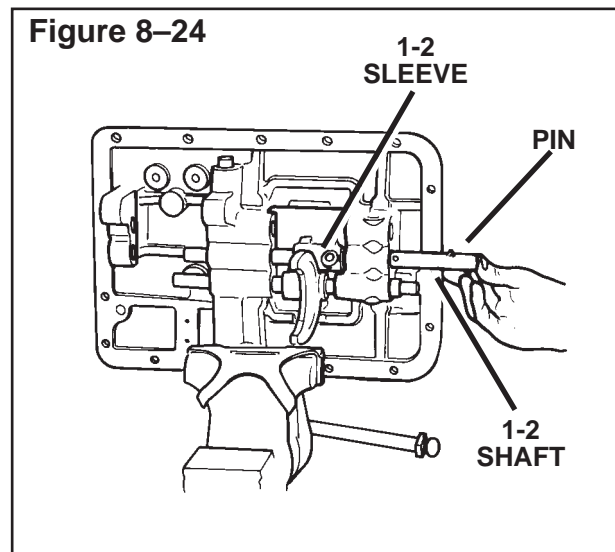

- c. Put the 1-2 shift sleeve in the housing. Make sure the bore of the sleeve is aligned with the bore in the housing. Make sure the threaded hole in the sleeve is toward the rear of the housing. **Figure 8-24.**
- d. Push the shift shaft through the 1-2 shift sleeve. **Figure 8-24.**
- e. Put the 1-2 shift fork in the housing. Make sure bend on the fork is installed toward the middle set of shift rail bores in the top cover housing. Make sure the bore of the fork is aligned with the bore in the housing. **Figure 8-25.**
- f. Push the shift shaft through the 1-2 fork. **Figure 8-25.**

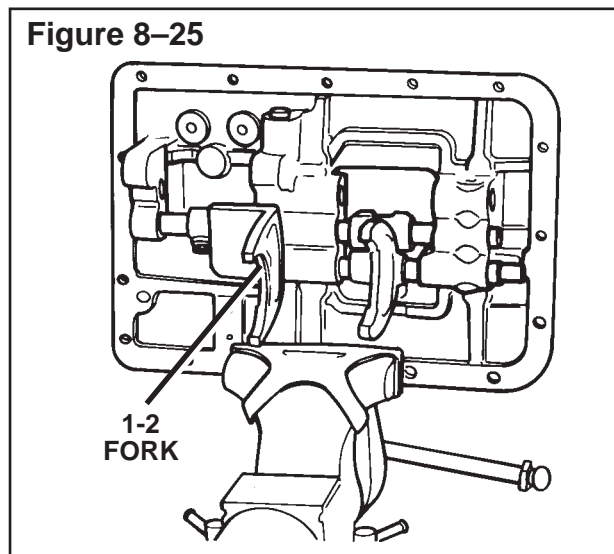

- g. Push the shaft through the assembly until the holes in the fork and the sleeve are aligned with the holes in the shaft.

! CAUTION

After the set screws with the Loctite® sealant (see step 2) are tightened to the specified torque, do not loosen or tighten. If loosened or tightened, the set screws must be removed, cleaned and new sealant applied or the cap-screws may loosen during operation.

- h. Install the set screw with the Loctite® sealant (see step 2) that fasten the fork and the sleeve in position on the shaft. Tighten the set screw to 35-45 lb-ft (47-54 N.m). **T**
 - i. Install the lock wire in the holes in the set screws.
12. Put the interlock ball in the bottom of the top bore of the first set of bores at the rear of the housing. **Figure 8-26.**

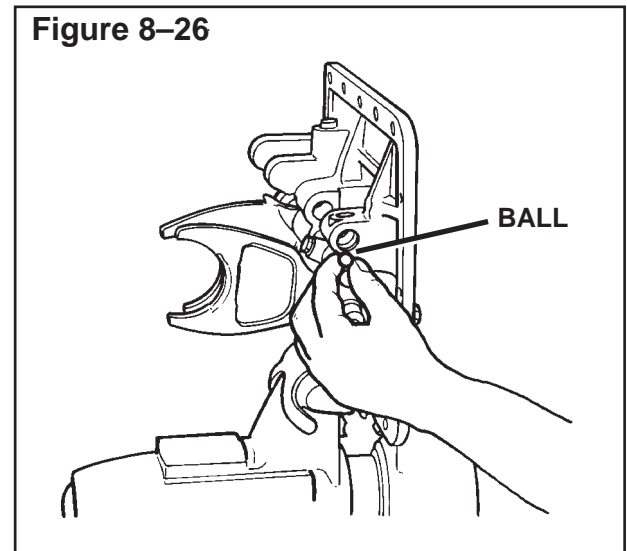

13. Make sure the low-reverse sleeve and the 1-2 sleeve are in the **NEUTRAL** position. The slots in the sleeve must be aligned. **Figure 8-27.**

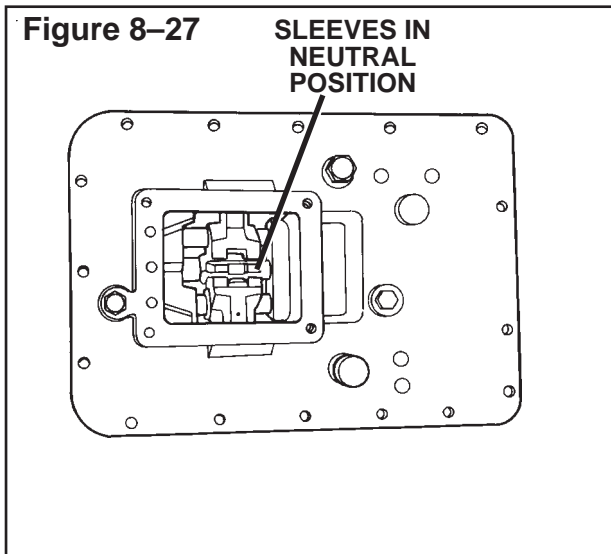

14. If removed, install the plunger assembly in the 3-4 shift sleeve. Put the sleeve in a vise with brass jaws. Install the spring (if used) and the plunger in the sleeve. Install the snap ring that holds the assembly in the fork. **Figure 8-28.**

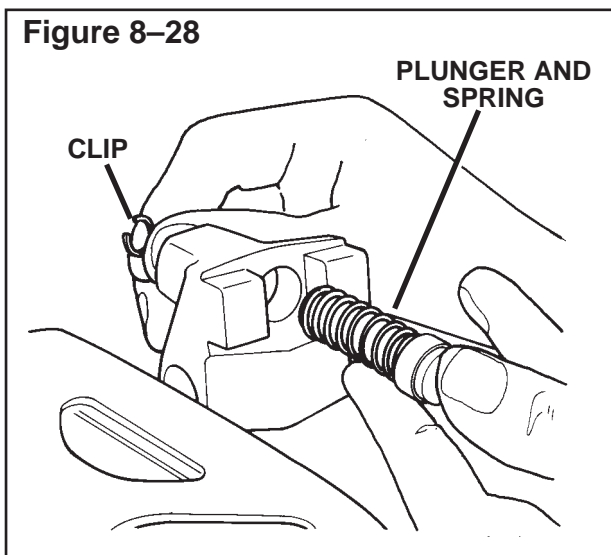

NOTE:

On R-ratio transmissions, the bill of material refers to the 3-4 shift fork as the O/D (Overdrive) shift fork and the 3-4 shift sleeve as the O/D shift sleeve.

15. Assemble the 3-4 shift rail assembly. See the following procedure.

NOTE:

The 3-4 shift shaft has a slot on one side

NOTE:

Move the 1-2 shift shaft assembly so that the interlock ball is completely installed in the bore. Move the 1-2 shaft assembly so that the 3-4 shaft can be installed.

- a. Put the 3-4 shift shaft in the top bore of the housing. Make sure the interlock slot on the end of the rail is toward the rear of the housing. Make sure the detent grooves in the shaft are aligned with the detent ball holes in the housing.

Figure 8-29.

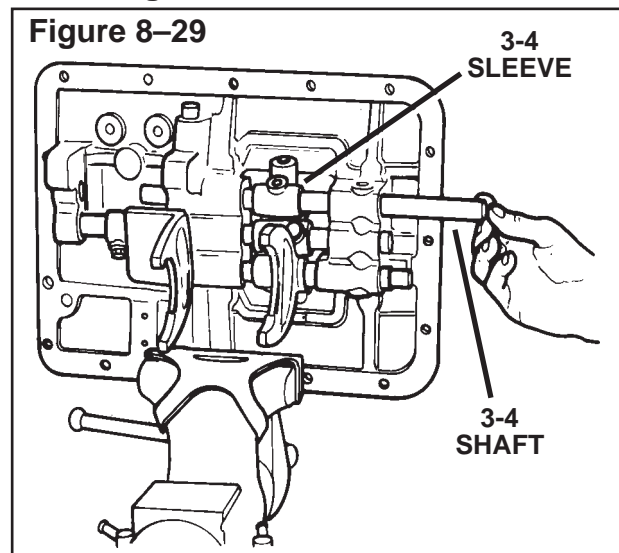

- b. Put the 3-4 shift sleeve in the housing. Make sure the bore of the fork and sleeve assembly is aligned with the bore in the housing. Make sure the slot pin in the 3-4 sleeve is aligned with the hole in the 1-2 sleeve. **Figure 8-30.**

Figure 8-30

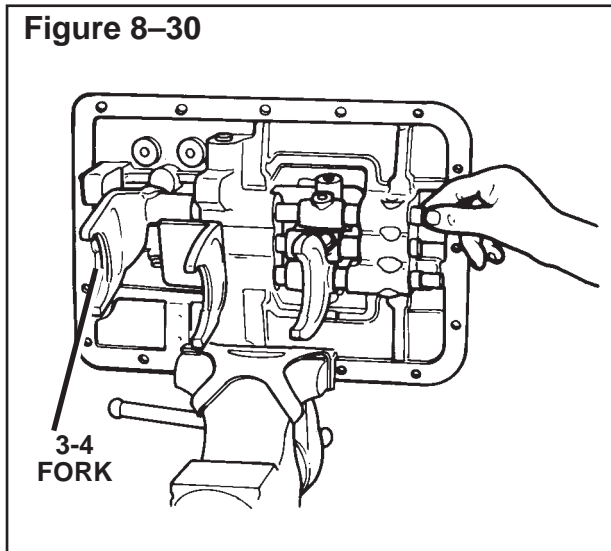

- c. Push the shift shaft through the 3-4 shift sleeve.
- e. Put the 3-4 shift fork in the housing. Make sure the bend on the fork is installed toward the last set of bores in the housing. Make sure the bore of the fork is aligned with the bore in the housing. **Figure 8-29.**
- f. Push the shift shaft through the 3-4 fork.
- g. Push the shaft through the assembly until the holes in the fork and the sleeve are aligned with the holes in the shaft.

! CAUTION

After the set screws with the Loctite® sealant (see step 2) are tightened to the specified torque, do not loosen or tighten. If loosened or tightened, the set screws must be removed, cleaned and new sealant applied or the set screws may loosen during operation.

- h. Install the set screws with the Loctite® sealant (see step 2) that fastens the 3-4 fork and the sleeve to the rail. Tighten the set screw to 35-45 lb-ft (47-54 N.m). **T**
 - i. Install the lock wire in the capscrews, the sleeve and the fork.
15. If removed, install the large oil scoop on the housing. Install and tighten the capscrews with the Loctite® sealant (see step 2) to 10-13 lb-ft (13-17 N.m). **Figure 8-31.** **T**
16. If removed, install the small scoop on the housing. Install and tighten the capscrews with the Loctite® sealant (see step 2) to 10-13 lb-ft (13-17 N.m). **Figure 8-31.** **T**

Figure 8-31

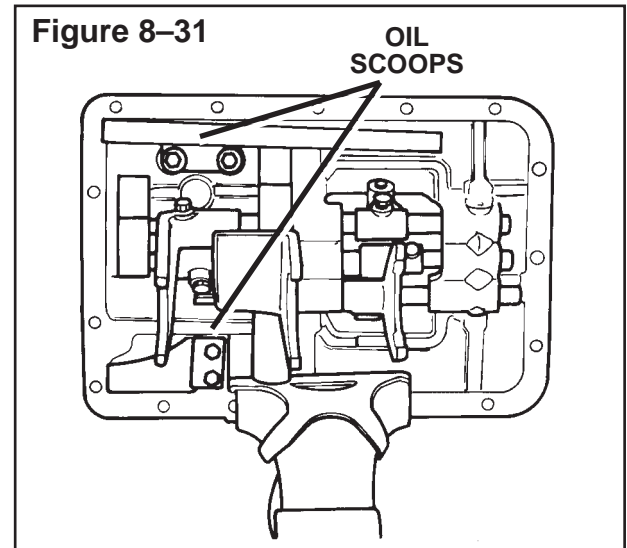

Section 8 Overhauling the Top Cover Assembly

"X" Bar Top Cover

Disassembling the Standard and the Forward Position "X" Bar Top Cover Assembly

See Figures 8-32 and 8-33.

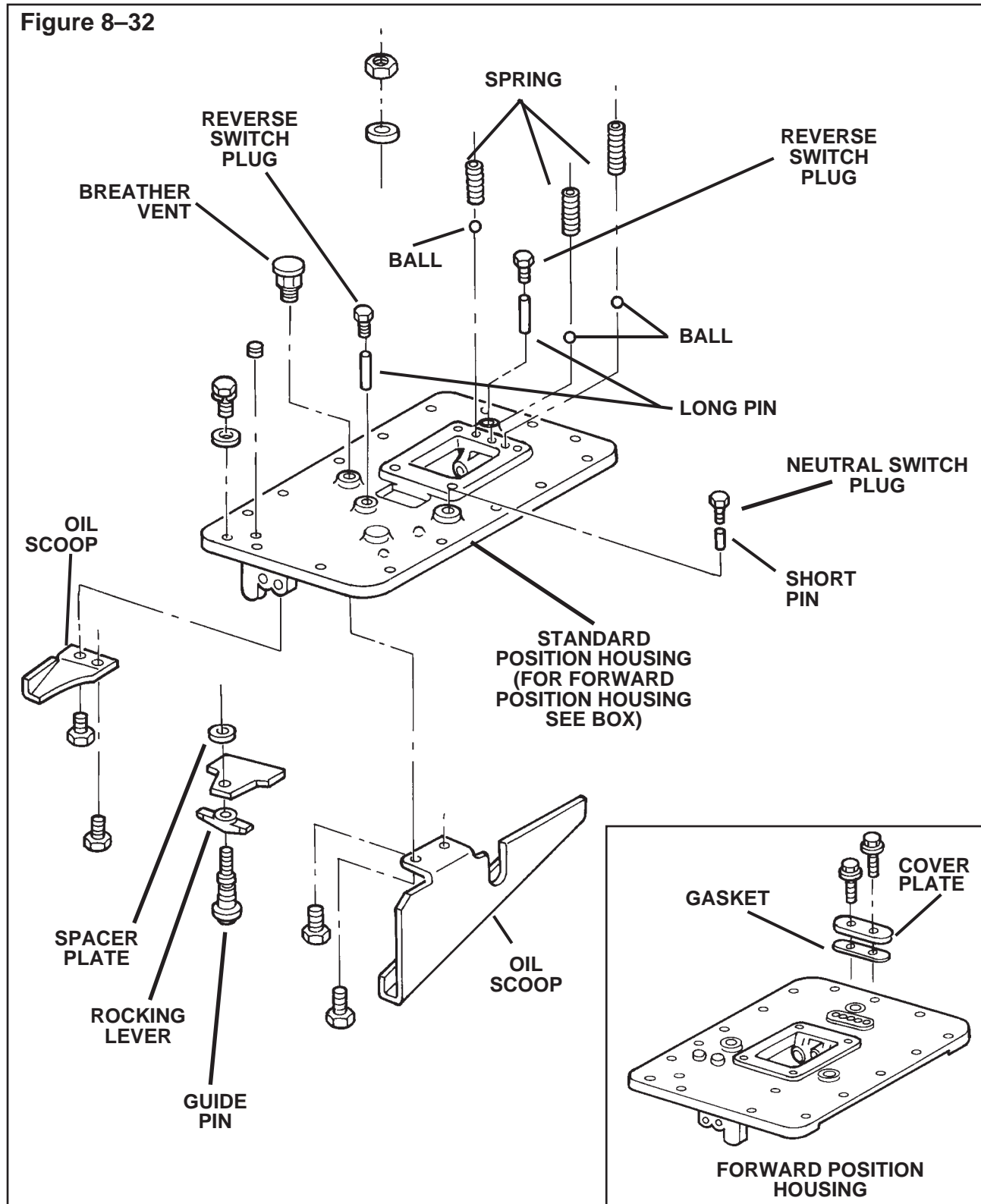

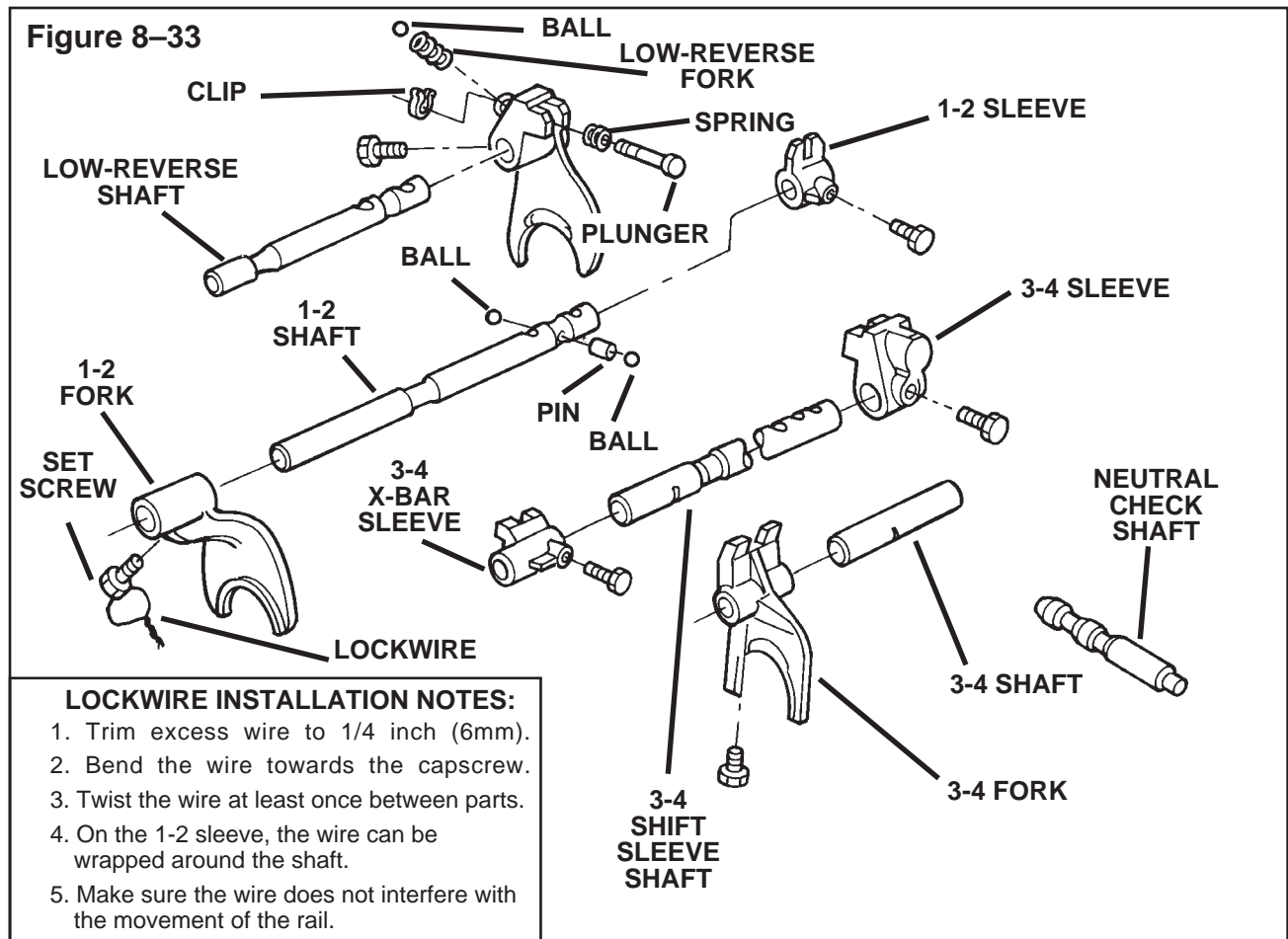

⚠ WARNING
To prevent serious eye injury, always wear safe eye protection when doing maintenance or service.

NOTE:
The standard position “X” bar top cover assembly and the forward position “X” top cover assembly use different housings. The forward housing also uses a plate and a gasket installed over the detent balls and springs.

1. Remove the top cover assembly as described in this section. Make sure the top cover assembly is in the **NEUTRAL** position. **Figure 8-34.**

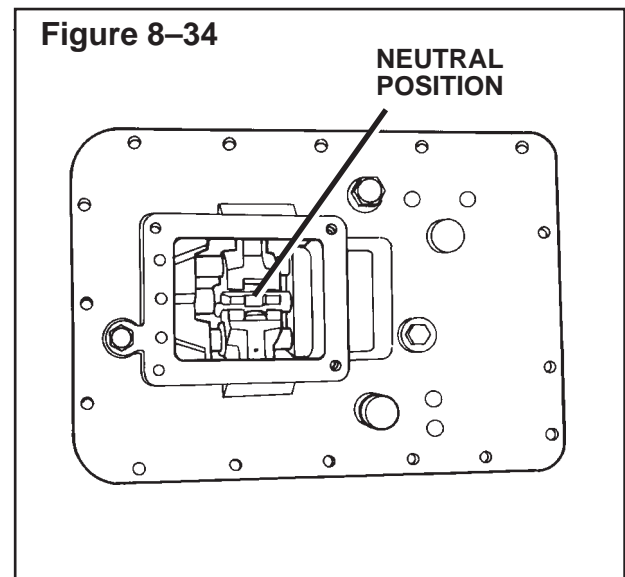

Section 8 Overhauling the Top Cover Assembly

“X” Bar Top Cover

2. On forward top covers, remove the capscrews that fasten the detent spring cover plate (if installed) to the top cover assembly. Remove the plate and the gasket.

NOTE:

If a heavy-duty detent spring is used, the spring (different color) in the bore on the slave valve side of the transmission.

3. If installed, remove the three detent springs and balls from the top of the housing. **Figure 8–35.**

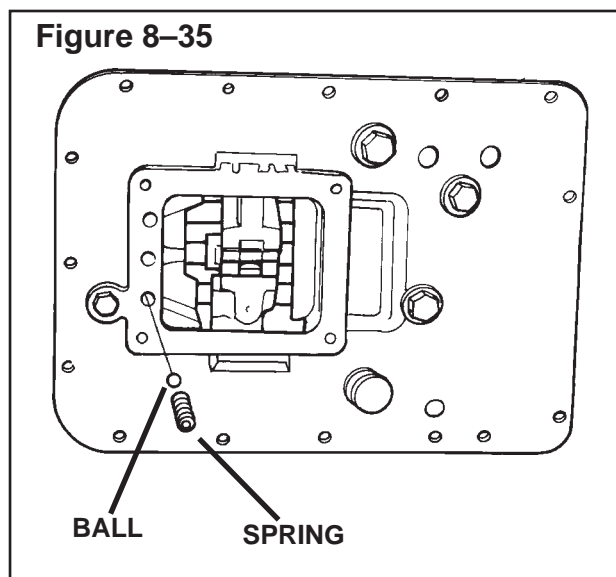

NOTE:

On standard position top cover assemblies, two reverse switches may be used. On forward position housings, one reverse switch is used.

4. Remove the reverse switches or plugs from the housing. Remove the long pins from each bore. **Figure 8–36.**

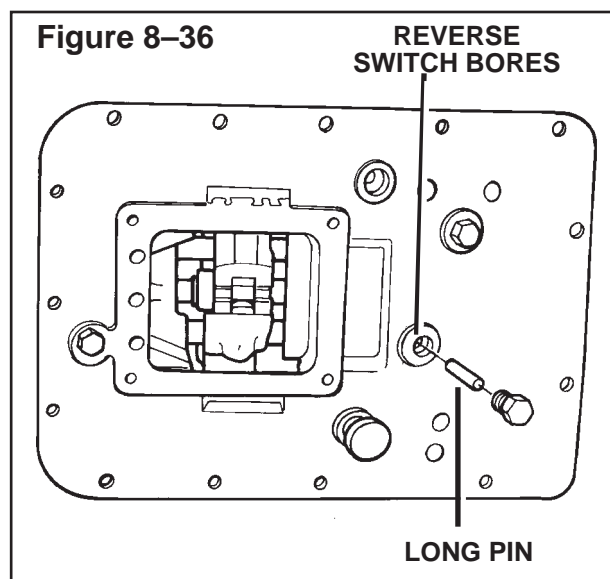

5. If necessary, remove the breather from the top of the cover. **Figure 8–37.**

6. Remove the neutral safety switch or plug. Remove the short pin from the bore. **Figure 8–37.**

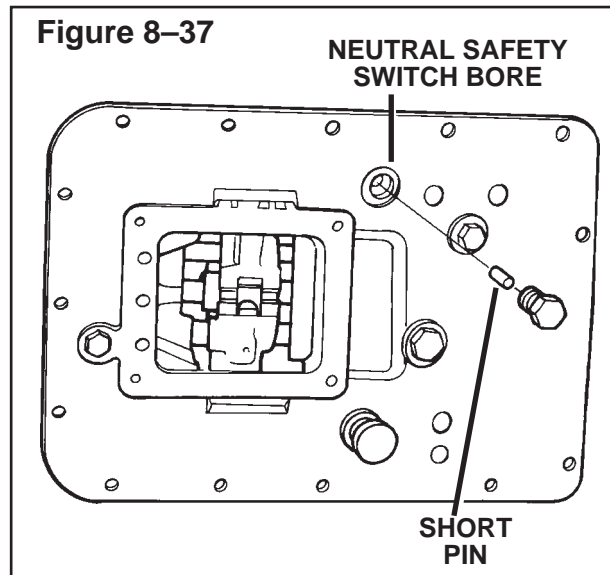

CAUTION

Do not damage the machined surface of the case. If the surface is damaged, the case will leak.

7. Put the top cover assembly on the bench so that the forks are toward you or in a vice with brass protectors on the jaws of the vise.

8. Remove the capscrews that fasten the large and the small oil scoops to the cover. **Figure 8-38.**

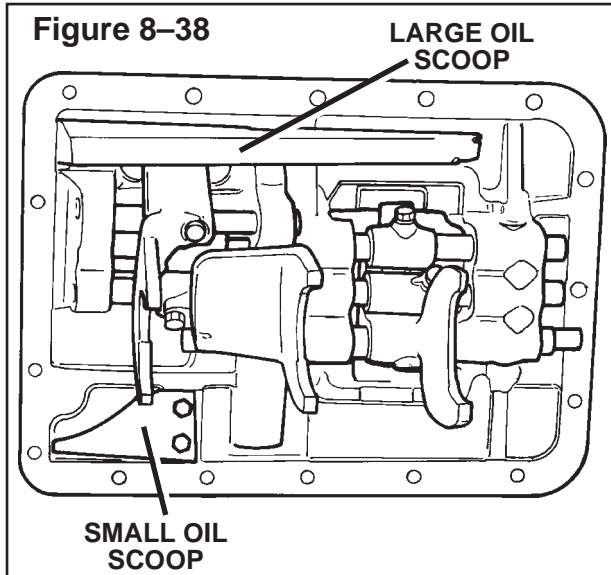

9. Remove the lock wire from the following. **Figure 8-39.**
- 3rd-4th fork.
 - 3rd-4th shift sleeve.
 - 1st-2nd shift fork.
 - 1st-2nd shift sleeve.
 - LOW-Reverse shift fork.

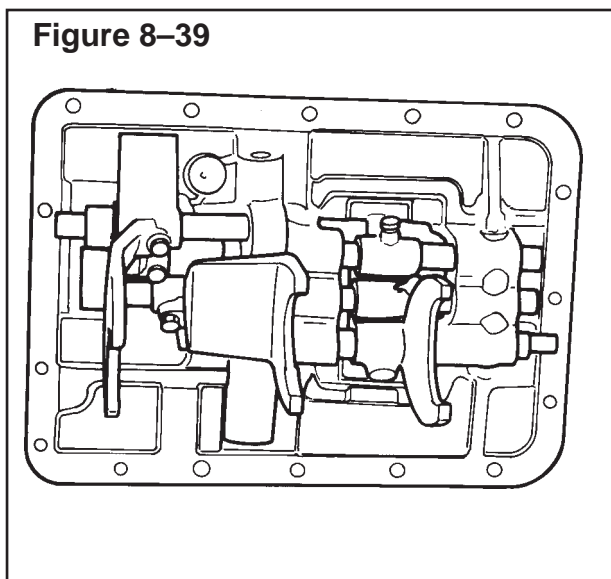

10. Remove the set screw from the 3rd-4th fork and the 3rd-4th shift fork shaft from the housing. Remove the 3rd-4th fork. **Figure 8-40.**

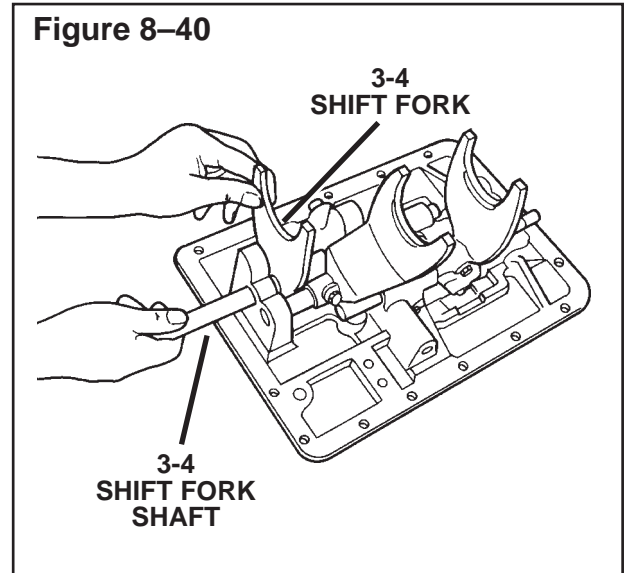

11. Remove the set screw and remove the 3-4 shift sleeve shaft from the housing. Remove the 3-4 X-bar sleeve. **Figure 8-41.**

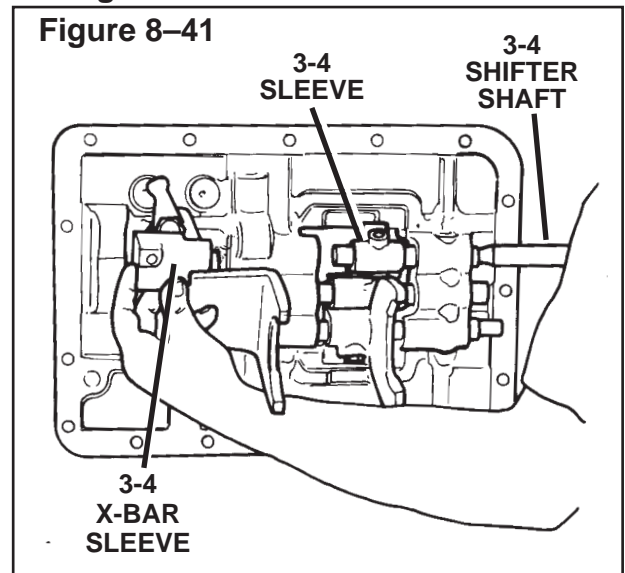

12. Remove the interlock ball from the bottom of the top bore of the first set of bores at the rear of the housing. **Figure 8-42.**

Section 8 Overhauling the Top Cover Assembly

“X” Bar Top Cover

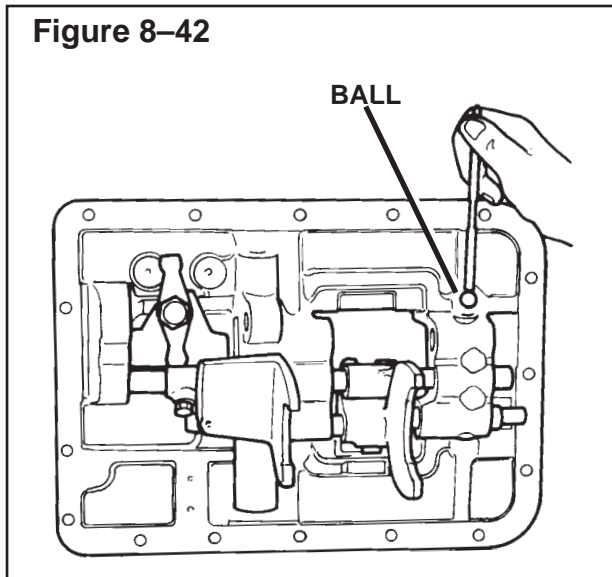

13. Remove the interlock pin from the end of the 1-2 shift shaft. **Figure 8-43.**

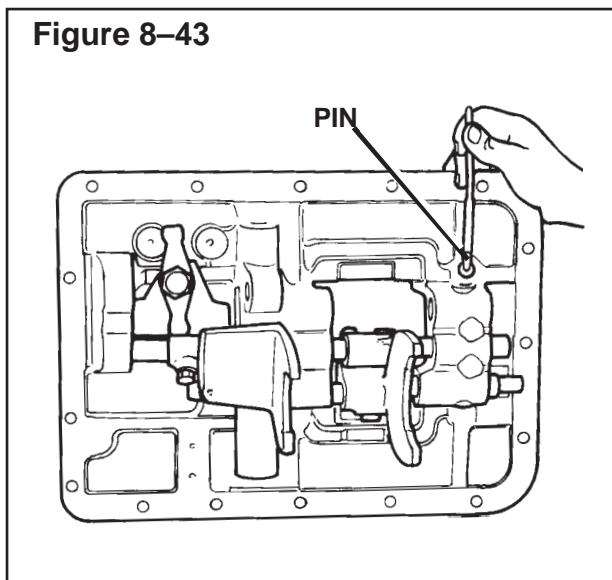

14. Remove the set screws and remove the 1-2 shift shaft, the 1-2 shift fork and the 1-2 shift sleeve from the housing. **Figure 8-44.**

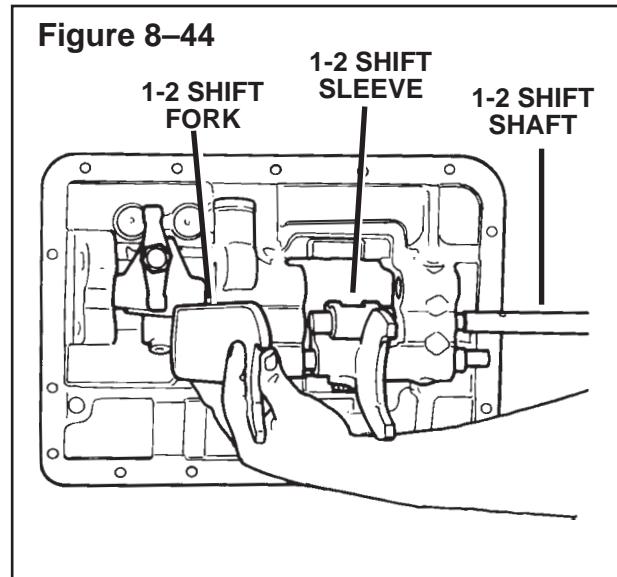

15. Remove the interlock ball from the bottom of the middle bore in the first set of bores in the rear of the housing. **Figure 8-45.**

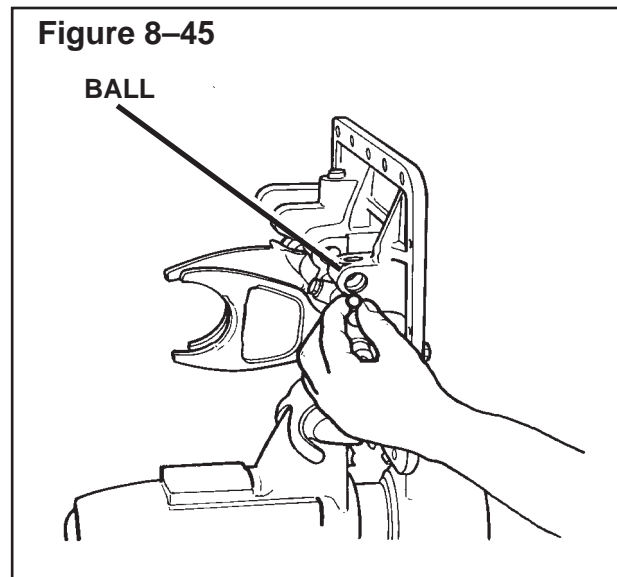

CAUTION

Remove the O-ring on the guide pin before removing the rocking lever and the spacer plate or the O-ring will be damaged.

16. Remove the nut and the washer that fasten the guide pin and the rocking lever assembly to the housing. Remove the O-ring from the guide pin. Remove the rocking lever and the spacer plate. **Figure 8-46.**

Inspect the O-ring on the guide pin. Replace the O-ring if worn or damaged.

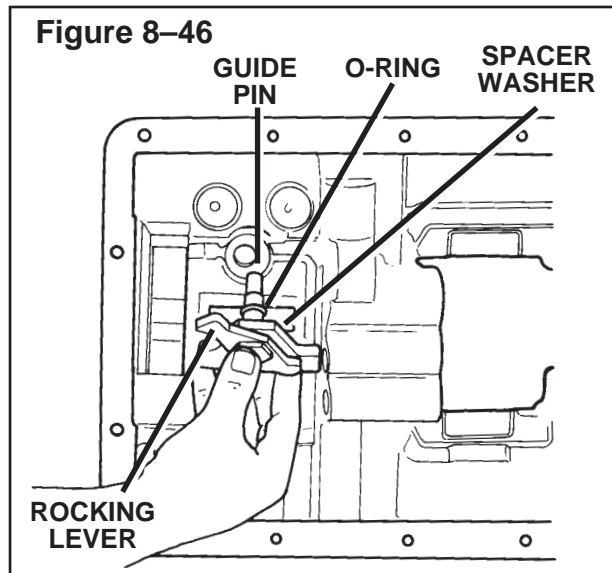

17. Remove the neutral check shaft from the top cover assembly. **Figure 8-47.**

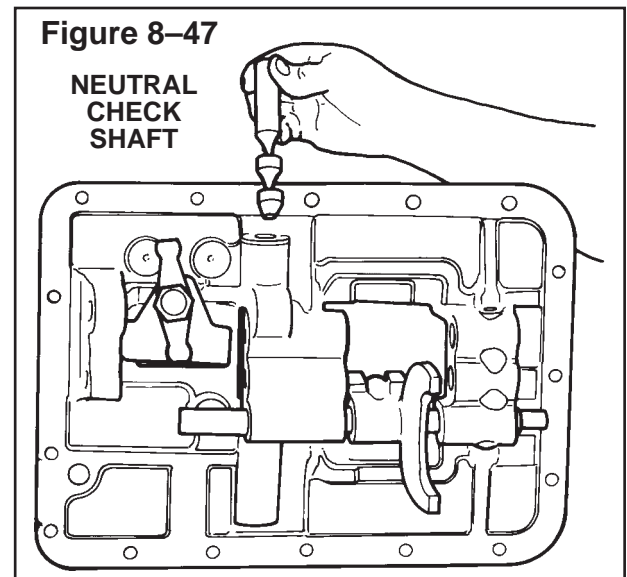

18. Remove set screws and remove the low-reverse shift shaft. Remove the low-reverse shift sleeve and fork assembly. **Figure 8-48.**

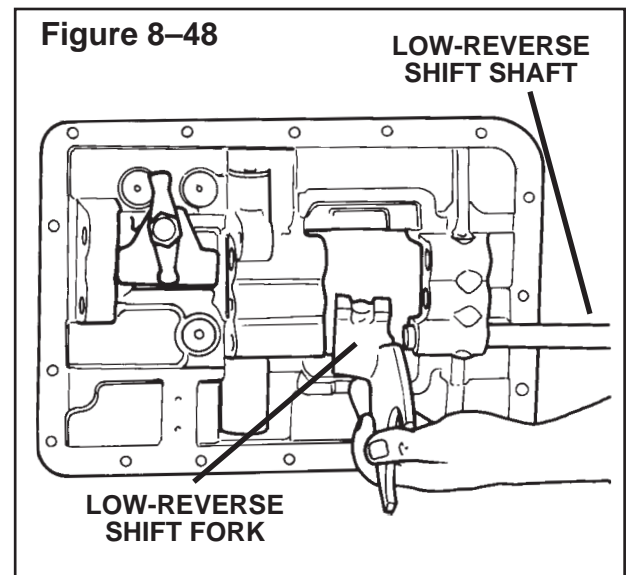

19. If necessary, disassemble the low-reverse sleeve and fork assembly. Remove the clip that fastens the plunger in the housing. Remove the plunger and the spring. Remove the spring and the ball from the bore next to the plunger bore. **Figure 8-49.**

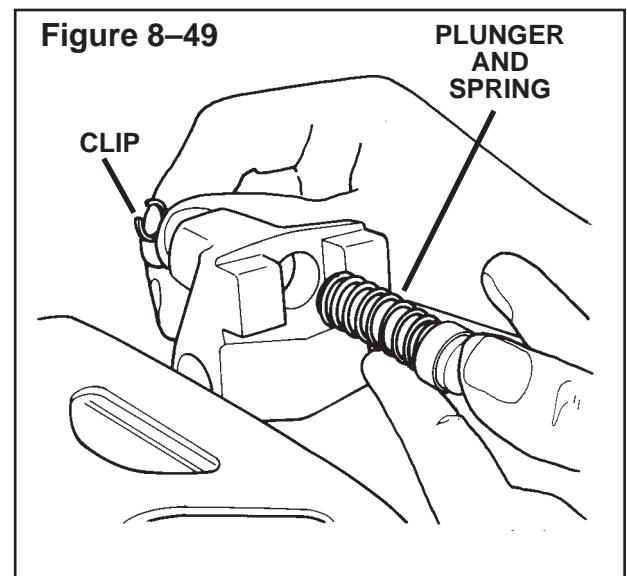

20. Inspect all parts. See Section 1, “Repairing or Replacing the Parts”.

Assembling the Standard and the Forward Position “X” Bar Top Cover Assembly

See Figure 8–32 and 8–33.

NOTE:

The standard position “X” bar top cover assembly and the forward position “X” bar top cover assembly uses different covers. The forward cover also uses a plate and a gasket installed over the detent balls and springs.

1. Lubricate all the parts of the top cover with the oil that is used in the transmission.
2. Do the following to the set screws that fasten the shift sleeves and/or forks to the shift shafts and the capscrews for the oil scoops.
 - a. Clean the threads of the fasteners with Loctite® Safety Solvent #755 (Meritor part number 2297-P-6412) or equivalent. Make sure all dirt is removed from the threads.

NOTE:

See the specifications of the sealant manufacturer for the “cure” time.

- b. Apply Loctite® #242 (Meritor part number 2297-V-5430) or equivalent to the threads of the fasteners.
3. If disassembled, install the plunger assembly in the low-reverse fork assembly. See the following.
Figure 8–50.
 - a. Put the fork in a vise with brass jaws.

- b. Install the ball and the spring in the bore next to the plunger.
- c. Install the plunger and the spring in the bore of the fork.
- d. Install the snap ring that holds the assembly in the fork.

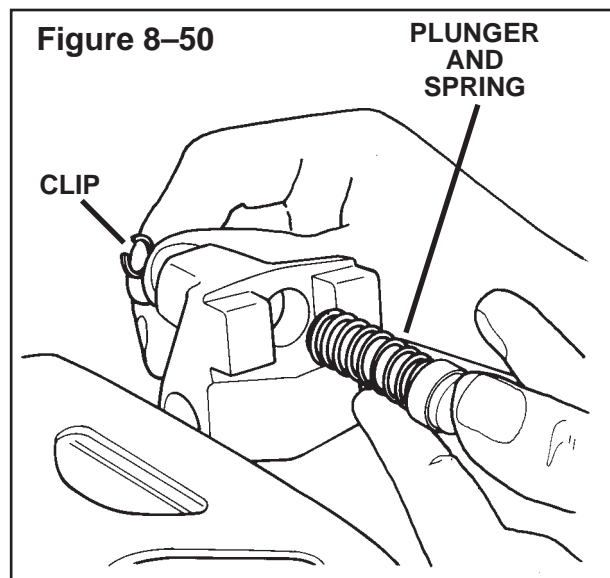

4. Assemble and install the rocking lever assembly according to the following procedure. **Figure 8–51.**
 - a. Install the guide pin through the rocking lever.
 - b. Install the spacer plate on the guide pin.



CAUTION

Install the O-ring on the guide pin after installing the rocking lever and the spacer plate or the O-ring will be damaged.

- c. Install a new O-ring on the guide pin.
 - d. Install the assembly so that the long part of the spacer plate is toward the center of the housing.

- e. Install a new nut and a new washer that fasten the guide pin to the housing. Tighten to 35-45 lb-ft (47-54 N.m). 

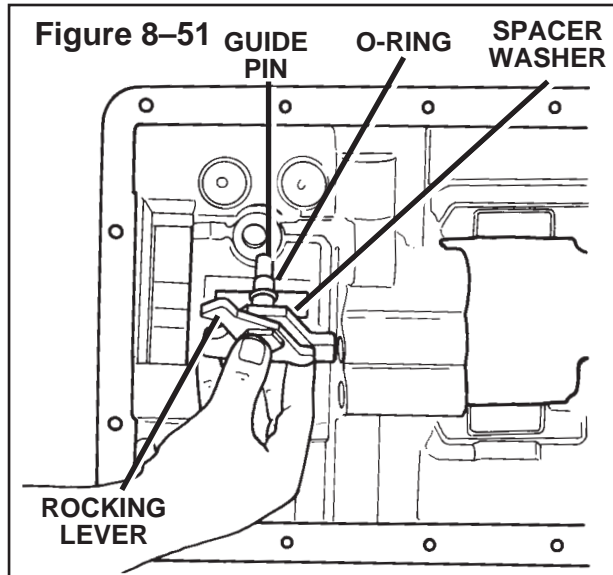

- 5. Install the low-reverse fork assembly according to the following procedure. **Figure 8-52.**

- a. Put the low-reverse shift shaft in the bottom bore in the rear of the housing. Make sure the two detent grooves are toward the rear of the housing. Make sure the detent grooves in the shaft are aligned with the detent ball holes in the housing.
- b. Put the low-reverse shift fork assembly in the housing so that the lower lever slot is toward the center of the assembly. Make sure the bore of the fork is aligned with the bore in the housing.
- c. Push the shift shaft through the fork and sleeve assembly until the holes in the fork and shaft are aligned.

 **CAUTION**

After the set screws with the Loctite® sealant (see step 2) are tightened to the specified torque, do not loosen or tighten. If loosened or tightened, the set screws must be removed, cleaned and new sealant applied or the set screws may loosen during operation.

- d. Install the set screw with the Loctite® sealant (see step 2) that fasten the fork in position on the shaft. Tighten the set screw to 35-45 lb-ft (47-54 N.m). 
- e. Install the lock wire in the holes in the set screw and the fork assembly.

Figure 8-52



- 6. Install the neutral check shaft in the bore on the top of the housing. Make sure the round end of the shaft is installed toward the low-reverse shift rail. Make sure the end of the shaft touches the slot in the rail.

Figure 8-53.

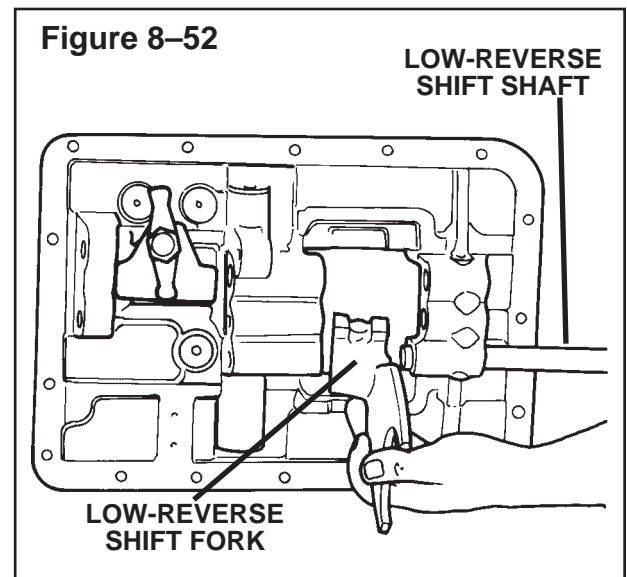
Section 8 Overhauling the Top Cover Assembly

“X” Bar Top Cover

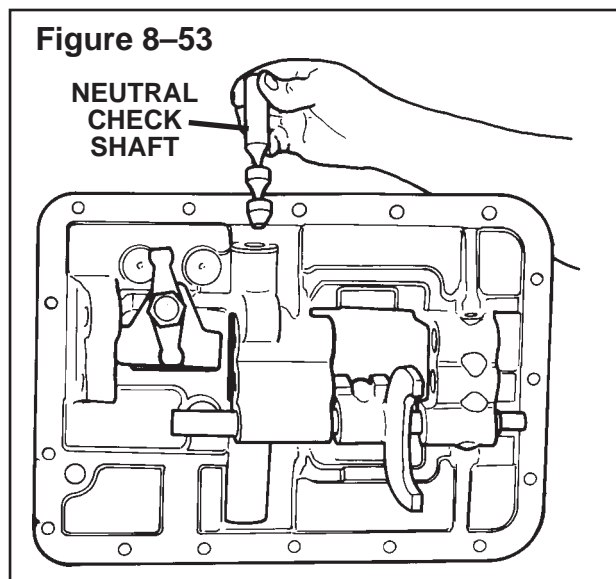

- Put the large interlock ball in the bottom of the middle bore of the first set of bores on the rear of the housing. **Figure 8-54.**

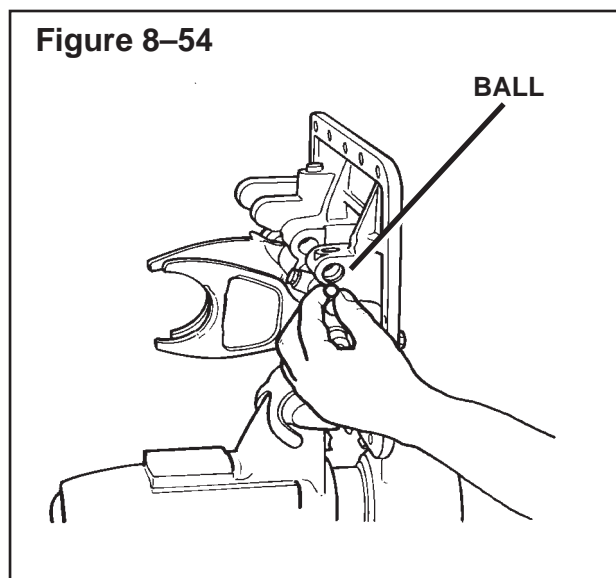

- Assemble the 1-2 shift shaft assembly. See the following procedure.

NOTE:

The 1-2 shift shaft is the same size as the 3-4 shift shaft and has a hole drilled through the shaft.

NOTE:

Move the low-reverse shift shaft assembly so that the interlock ball is completely installed in the bore. Move the low-reverse shaft assembly so that the 1-2 shaft can be installed.

- Put the 1-2 shift shaft in the middle bore of the housing. Make sure the part identification on the end of the shaft is toward the front of the housing. Make sure the detent grooves in the shaft are aligned with the detent ball holes. **Figure 8-55.**

- Put the 1-2 shift sleeve in the housing. Make sure the bore of the sleeve is aligned with the bore in the housing. Make sure the threaded hole in the sleeve is toward the rear of the housing. **Figure 8-55.**
- Push the shift shaft through the 1-2 shift sleeve. **Figure 8-55.**
- Put the 1-2 shift fork in the housing. Make sure bend on the fork is installed toward the middle set of bores. Make sure the bore of the fork is aligned with the bore in the housing. **Figure 8-55.**

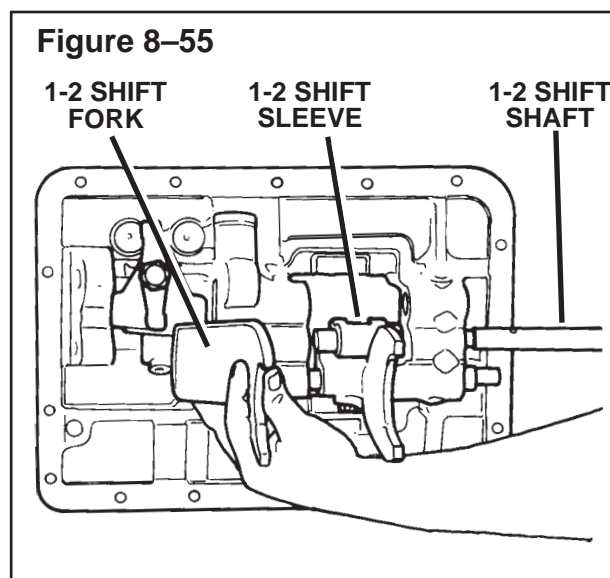

- e. Push the shift shaft through the 1-2 fork. **Figure 8-55.**
- f. Push the rail through the assembly until the holes in the fork and the sleeve are aligned with the holes in the shaft.

! CAUTION

After the set screws with the Loctite® sealant (see step 2) are tightened to the specified torque, do not loosen or tighten. If loosened or tightened, the set screws must be removed, cleaned and new sealant applied or the set screws may loosen during operation.

- g. Install the set screws with the Loctite® sealant (see step 2) that fastens the 1-2 fork and the sleeve to the rail. Tighten the set screws to 35-45 lb-ft (47-54 N.m). **T**
- h. Install the lock wire in the holes in the set screws and the fork and the sleeve. Wrap the lock wire around the barrel of the shaft.
- i. Put the interlock pin in the hole drilled in the end of the 1-2 shift shaft. **Figure 8-56.**

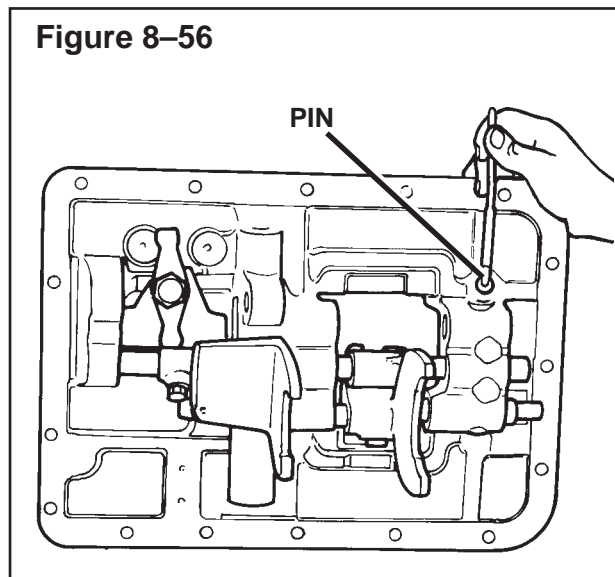

- 9. Put the interlock ball in the bottom of the top bore of the first set of bores at the rear of the housing. **Figure 8-57.**

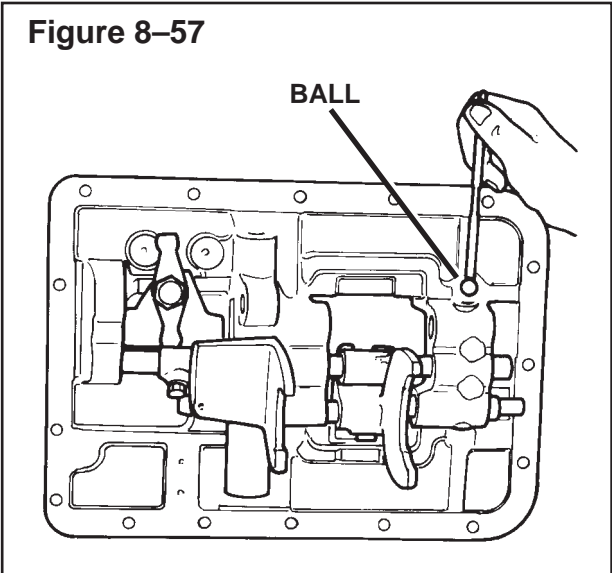

- 10. Make sure the low-reverse sleeve and the 1-2 sleeve are in the **NEUTRAL** position. The slots in the sleeve must be aligned.

NOTE:
On R-ratio transmissions, the bill of material refers to the 3-4 shift fork as the O/D (Overdrive) shift fork and the 3-4 “X” bar sleeve as the O/D shift sleeve.

- 11. Assemble the 3-4 shift sleeve and shaft assembly. See the following procedure.

NOTE:
The 3-4 shift sleeve shaft has a slot on one side

NOTE:
Move the 1-2 shift shaft assembly so that the interlock ball is completely installed in the bore. Move the 1-2 shaft assembly so that the 3-4 shift sleeve shaft can be installed.

Section 8 Overhauling the Top Cover Assembly

“X” Bar Top Cover

- a. Put the 3-4 shift sleeve shaft in the top bore of the housing. Make sure the interlock slot on the end of the shaft is toward the rear of the housing. Make sure the detent grooves in the shaft are aligned with the detent ball holes in the housing. **Figure 8–58.**
- b. Put the 3-4 shift sleeve in the housing. Make sure the bore of the sleeve is aligned with the bore in the housing. Make sure the slot in the 3-4 shift sleeve is aligned with the slot in the 1-2 sleeve. **Figure 8–58.**
- c. Push the shift shaft through the 3-4 shift sleeve.
- e. Put the 3-4 “X” bar sleeve in the housing. Make sure the slot is in the sleeve is aligned over the rocking lever assembly. Make sure the bore of the sleeve is aligned with the bore in the housing. **Figure 8–58.**
- f. Push the shift shaft through the 3-4 “X” bar sleeve.
- g. Push the shaft through the assembly until the holes in the sleeves are aligned with the holes in the shaft.

CAUTION

After the set screws with the Loctite® sealant (see step 2) are tightened to the specified torque, do not loosen or tighten. If loosened or tightened, the set screws must be removed, cleaned and new sealant applied or the set screws may loosen during operation.

- h. Install the set screws with the Loctite® sealant (see step 2) that fastens the sleeves to the shaft. Tighten the set screws to 35-45 lb-ft (47-54 N.m). 
- i. Install the lock wire in the holes in the sleeves and the set screws.

NOTE:

On R-ratio transmissions, the bill of material refers to the 3-4 shift fork as the O/D (Overdrive) shift fork and the 3-4 “X” bar sleeve as the O/D shift sleeve.

12. Install the 3-4 fork and 3-4 shift fork shaft according to the following procedure.
 - a. Put the 3-4 shift fork shaft in the top bore at the front of the housing. **Figure 8–59.**
 - b. Put the 3-4 shift fork in the housing. Make sure the slot on the fork is aligned with the rocking lever assembly. Make sure the bore of the fork and sleeve assembly is aligned with the bore in the housing. **Figure 8–59.**

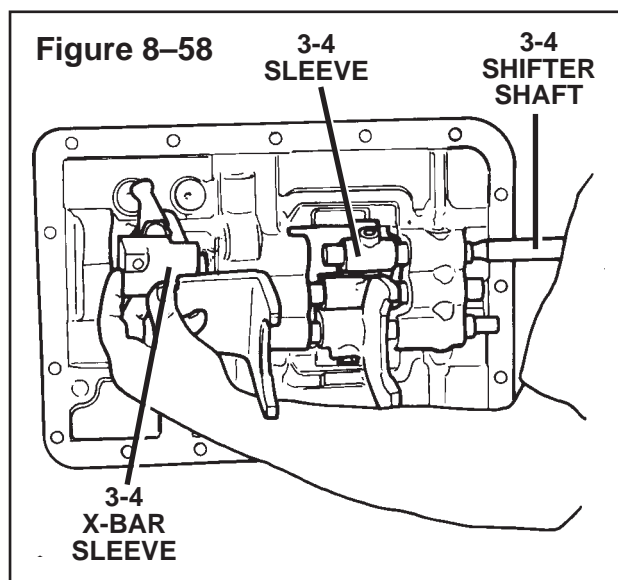

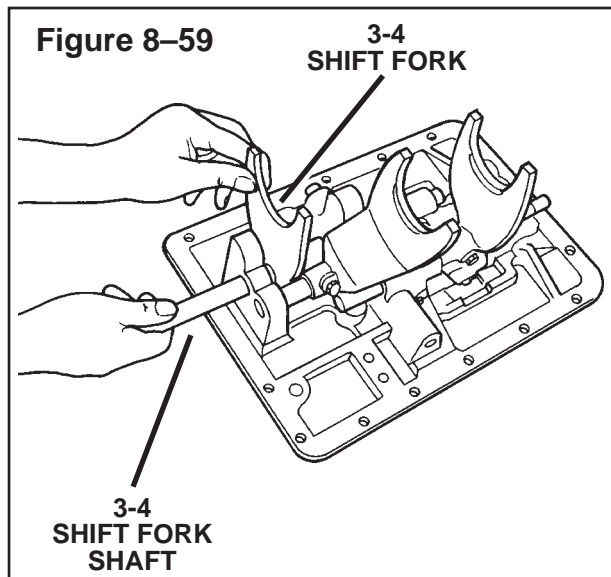

- c. Push the shift shaft through the 3-4 fork.

CAUTION

After the set screws with the Loctite® sealant (see step 2) are tightened to the specified torque, do not loosen or tighten. If loosened or tightened, the set screws must be removed, cleaned and new sealant applied or the set screws may loosen during operation.

- d. Install the set screw with the Loctite® Sealant (see step 2) that fastens the 3-4 fork to the shaft. Tighten the set screw to 35-45 lb-ft (47-54 N.m). **T**
- e. Install the lock wire in the holes in the set screws and the fork.
13. If removed, install the large and small oil scoops on the housing. Install and tighten the capscrews with the Loctite® sealant (see step 2) to 10-13 lb-ft (14-17 N.m). **Figure 8-60.** **T**

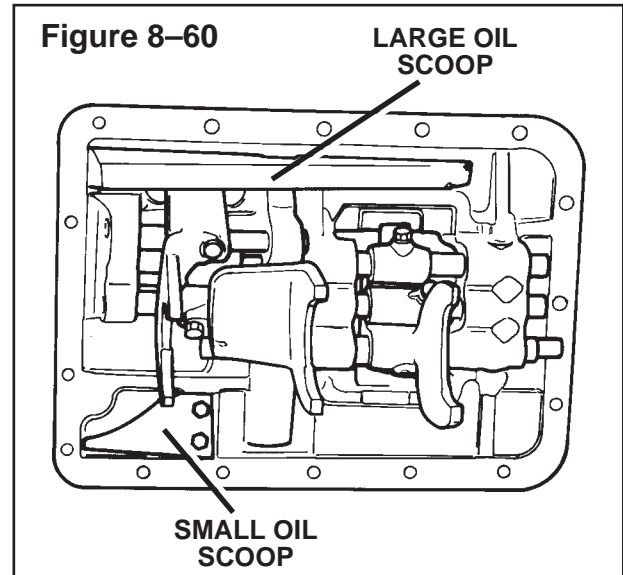

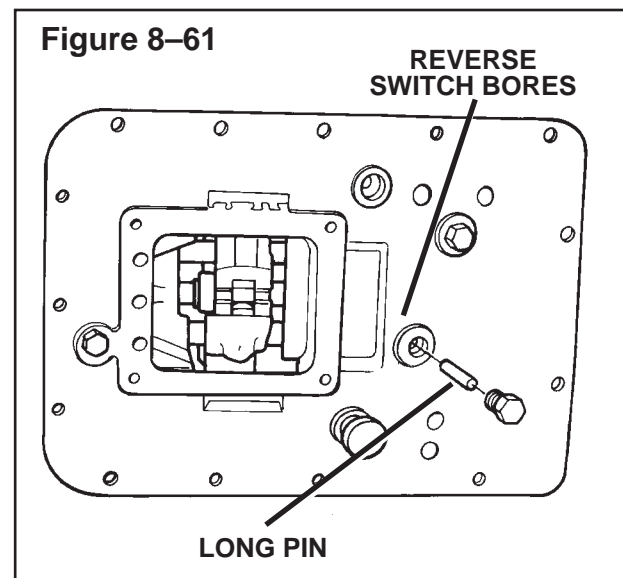

NOTE:
On standard position top covers assemblies, one or two reverse switches may be used. On forward position top covers, one reverse switch is used.

14. Install the larger pin(s) in the bore(s) for the reverse lamp switch. Install the switches or plugs and tighten to 35-50 lb-ft (48-67 N.m). **Figure 8-61.** **T**



Section 8 Overhauling the Top Cover Assembly

“X” Bar Top Cover

15. Install the short pin in the bore for the neutral safety switch. Install the switch or plug and tighten to 35-50 lb-ft (48-67 N.m). **Figure 8-62.** 
16. Install the breather vent in the top cover. Tighten to 15-20 lb-ft (21-27 N.m). **Figure 8-62.** 

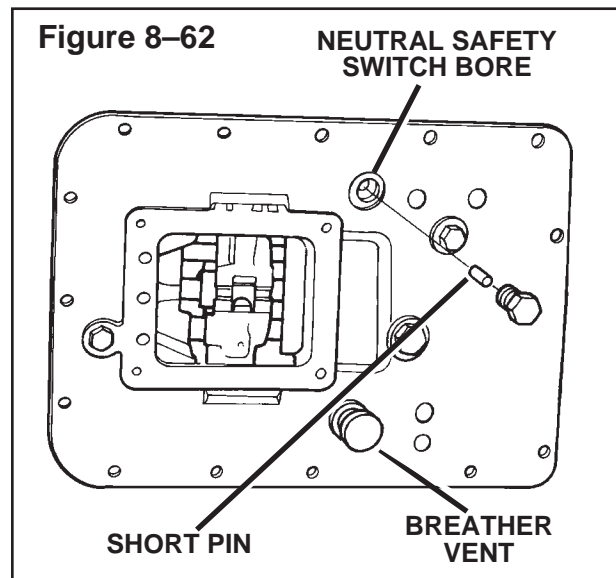

Section 9

Removing and Installing the Input Shaft



WARNING

To prevent serious eye injury, always wear safe eye protection when doing maintenance or service.

Removing the Input Shaft Assembly

NOTE:

The input shaft can be removed without disassembling the transmission.

1. Remove the transmission from the vehicle. See the procedure in this section.



CAUTION

Use a rubber mallet or “dead blow” hammer to separate the top cover from the transmission case. Do not use pry bars or screwdrivers to separate the cover from the case. Pry bars or screwdrivers may damage the cover and case mounting surfaces. If the cover is still difficult to remove, remove the slave valve and the interlock pin from the main case.

2. Remove the capscrews and the washers that fasten the input bearing retainer to the main case. Remove the input bearing retainer. **Figure 9-1.**

Figure 9-1

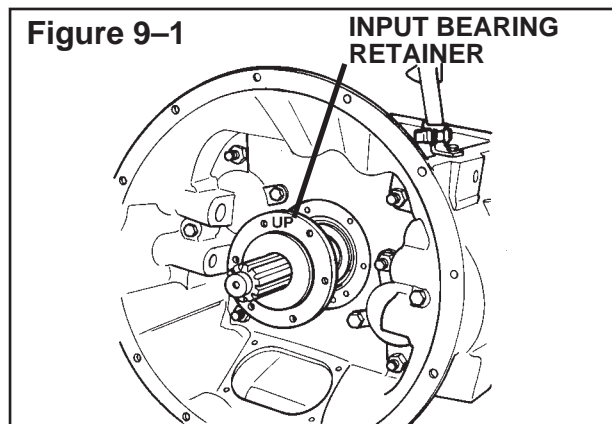

3. Use a scraper to remove the sealant material between the input bearing retainer and the main case.

NOTE:

A black shipping seal may be on the input shaft. Remove and discard the seal.

4. Remove the inner snap ring that holds the bearing on the input shaft.

Figure 9-2.

Figure 9-2

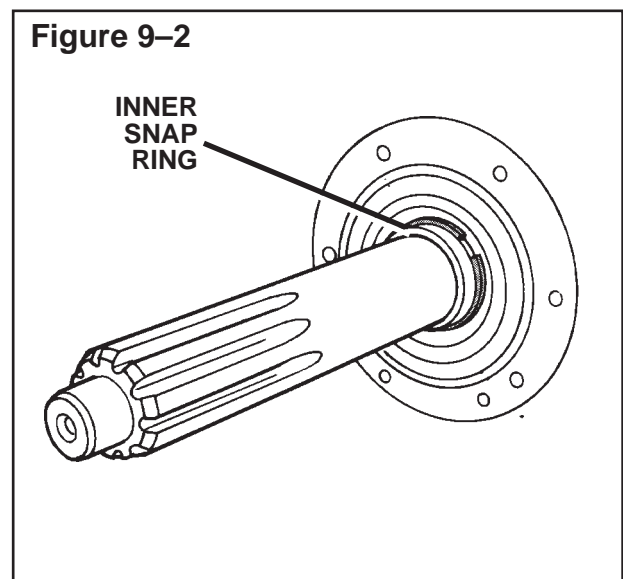

5. Remove the bearing from the shaft. The use of Owatonna tool set, OTC-7070 (as shown in **Figure 9-3**), or G&W Tool, G-38, Input Shaft Bearing Driver (as shown in **Figure 9-4**), or equivalent, makes the removal of the bearing from the shaft easier. The tool is attached to the outer snap ring on the bearing to pull the bearing from the shaft.

If the snap ring is not out far enough for the tool to grip, pull the input shaft out until the tool can be installed on the snap ring. **Figure 9-5.**

Section 9

Removing and Installing the Input Shaft

Figure 9-3

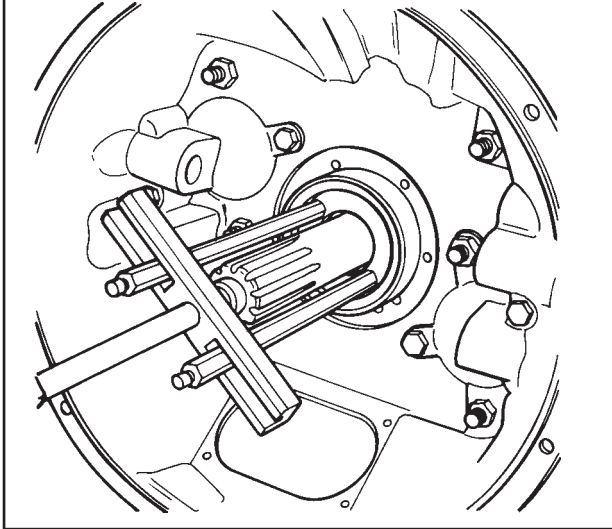

Figure 9-4

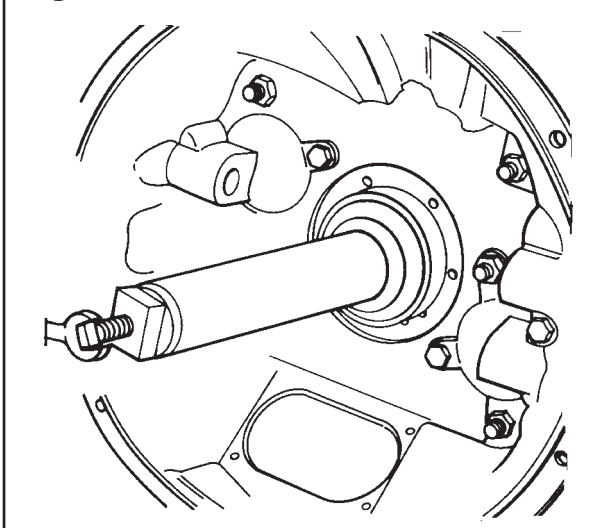
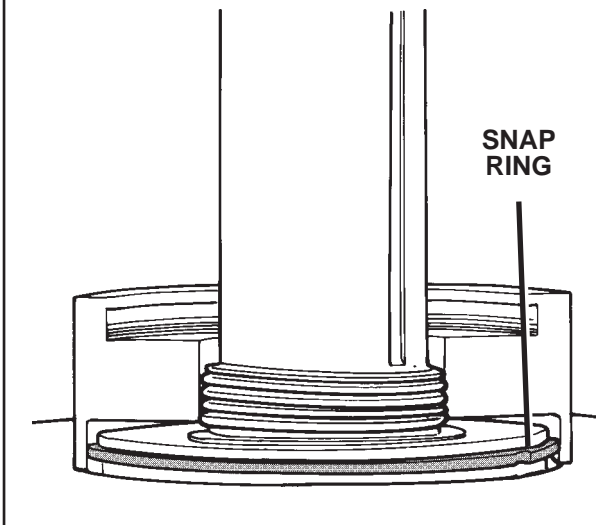
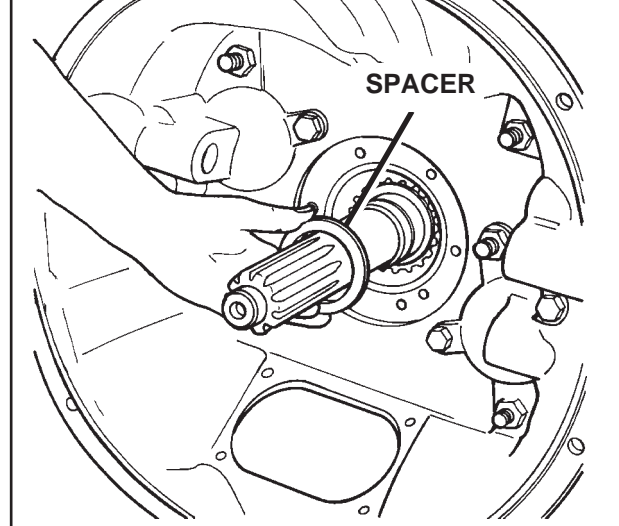

Figure 9-5



6. Remove the spacer from the input shaft. **Figure 9-6.**

Figure 9-6



7. Remove the snap ring from the gear that holds the input shaft in the gear. **Figure 9-7.**

Figure 9-7

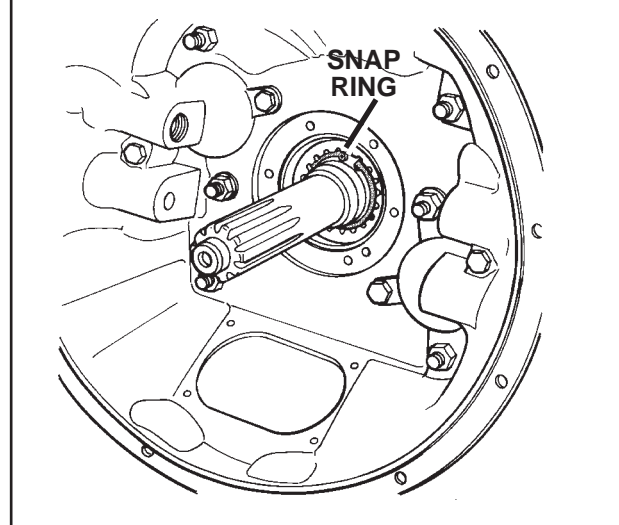

8. Remove the input shaft. **Figure 9-8.**

Section 9

Removing and Installing the Input Shaft

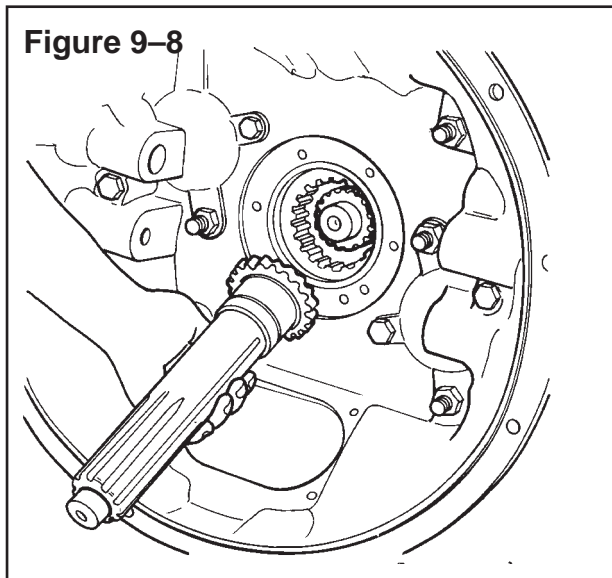

Figure 9-8

Installing the Input Shaft

NOTE:

The input shaft can be installed without disassembling the transmission.

1. Lubricate all the parts in the oil that is used in the transmission.
2. Align the splines of the input shaft with the splines inside the main drive gear. Install the input shaft in the main drive gear. Install the snap ring that holds the input shaft in the main drive gear. Install the spacer on the input shaft. **Figure 9-9.**

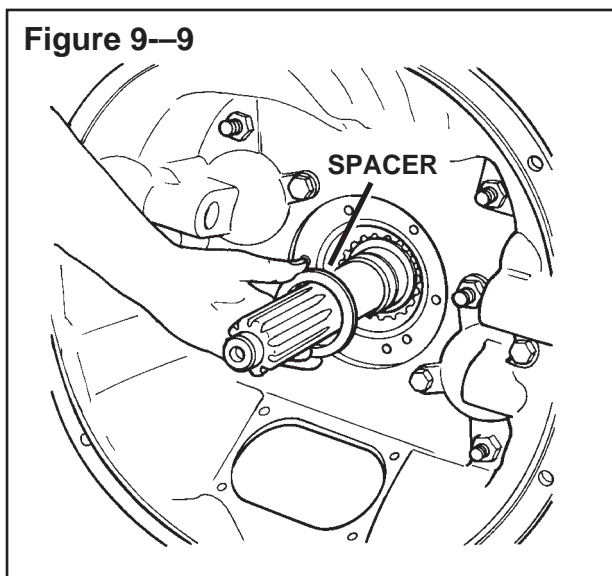

Figure 9-9

3. Install the outer snap ring in the groove on the bearing. **Figure 9-10.**

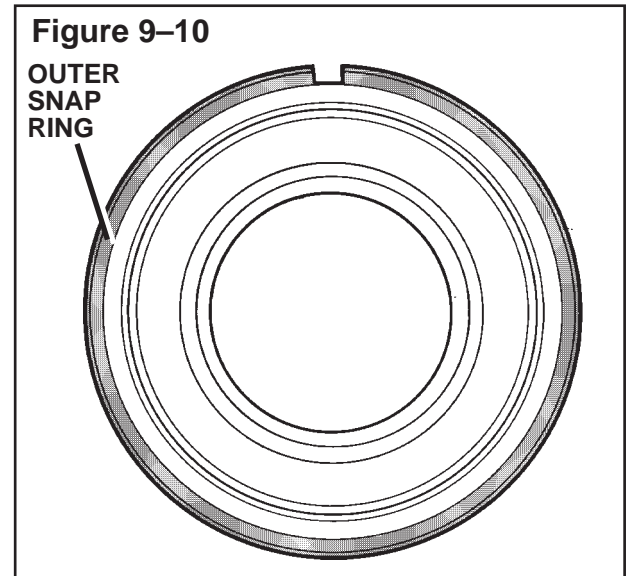

Figure 9-10



CAUTION

Put the tool or tube on the inner race of the bearing. If tools are used in any other place on the bearing, the bearing will be damaged.

4. Put the bearing over the input shaft and in the case. Use a rubber or plastic mallet and G & W Tool, G-35, Input Shaft Bearing Driver, to install the bearing on the input shaft. The bearing is correctly installed when the snap ring touches the case. **Figure 9-11.**

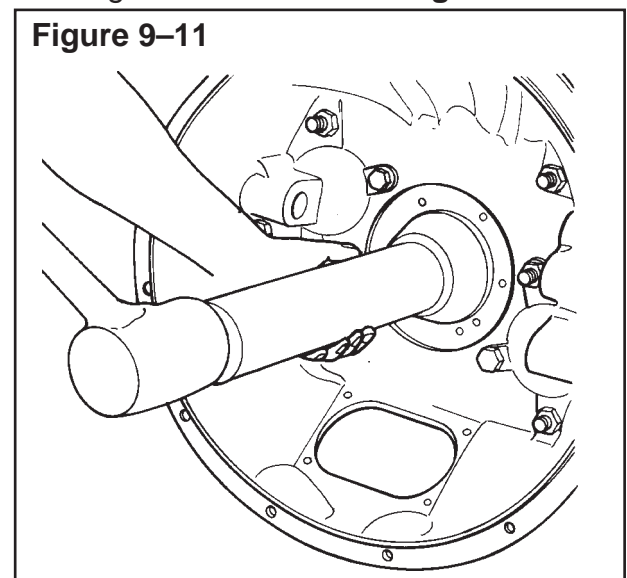

Figure 9-11

Section 9

Removing and Installing the Input Shaft

5. Install the inner snap ring that fastens the bearing on the input shaft.

Figure 9-12

6. Use Loctite® Master Gasket Sealant, #00203 or equivalent, and a sealant dispenser to put a new sealant pattern for the input bearing retainer on the case in the pattern shown in **Figure 9-13**.

See 'Gasket Sealant' in Section 1.

7. Install the bearing retainer on the case. Make sure the oil passage in the retainer is aligned with the oil hole in the case. **Figure 9-14**.

8. Install the capscrews and washers for the retainer. Tighten the capscrews to 65-85 lb-ft (89-115 N.m). **Figure 9-14**.



9. Install the top cover and the transmission. See the procedure in this section.

10. Operate the vehicle. Check for correct operation.

Figure 9-12

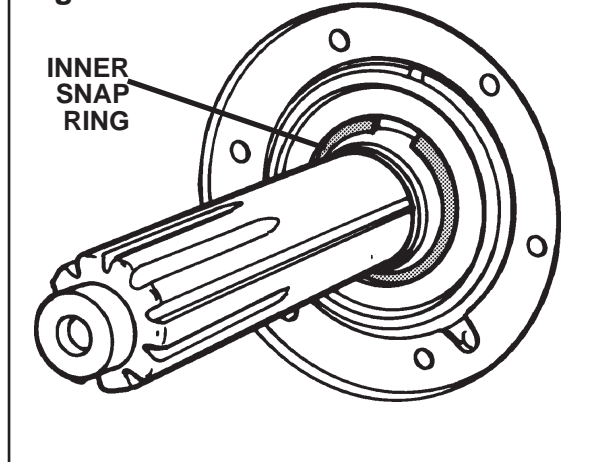

Figure 9-13

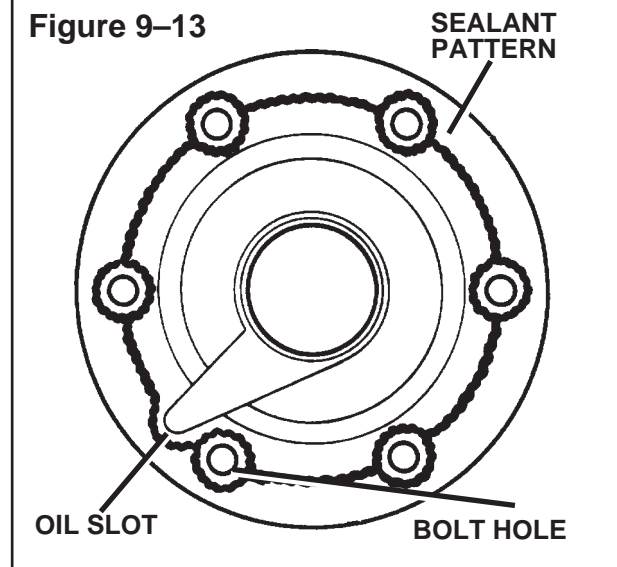
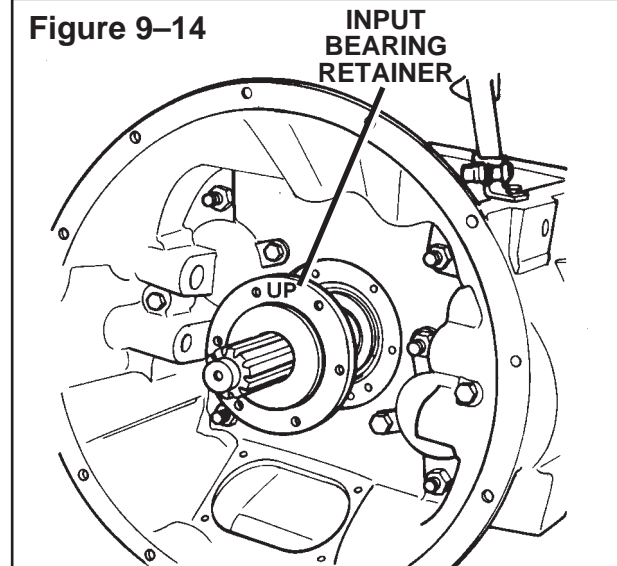

Figure 9-14



Removing and Installing the Clutch Housing



WARNING

To prevent serious eye injury, always wear safe eye protection when doing maintenance or service.

Removing the Clutch Housing

Figure 10-1.

1. Remove the transmission as described in Section 1, "In-Vehicle Service."
2. Remove the nuts, the capscrews and the washers that fasten the clutch housing to the main case.
3. Remove the clutch housing.
4. Use a scraper to remove all sealant material from the clutch housing and the main case.

Figure 10-1

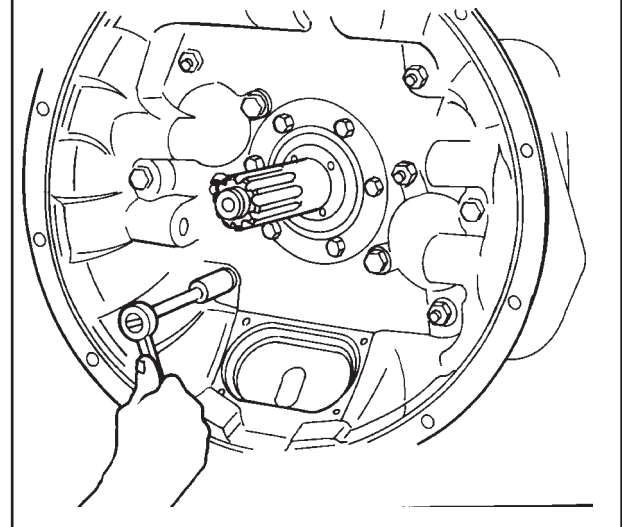

Installing the Clutch Housing

NOTE:

Clutch housings for Design Level 1 transmissions cannot be used on Design Level 2 transmissions. Clutch housings for Design Level 2 transmissions can be used on Design Level 1 transmissions. See the chart in Figure 10-2 to choose the correct clutch housing.

Figure 10-2

Clutch Housing Assembly - Above Centerline Clutch Release Shaft



Original Part Number	Design Level	Clutch Housing Type	Replacement Part Number	Design Level
A-3282-M-1001	1	SAE#1, Iron-Standard	A-3282-Z-1040	1,2
A-3282-T-1008	1	SAE#1, Iron-Symmetrical Nodal	A-3282-X-1038	1,2
A-3282-V-1010	1	SAE#1, Aluminum-Standard	A-3282-V-1036	1,2
A-3282-X-1012	1	SAE#1, Aluminum-Symmetrical Nodal	A-3282-B-1042	1,2
A-3282-P-1030	1	SAE#2, Iron-Standard	A-3282-D-1044	1,2

Clutch Housing Assembly - Below Centerline Clutch Release Shaft

Original Part Number	Design Level	Clutch Housing Type	Replacement Part Number	Design Level
A-3282-G-1021	1	SAE#1, Iron-Standard	A-3282-E-1045	1,2
A-3282-H-1022	1	SAE#1, Iron-Symmetrical Nodal	A-3282-G-1047	1,2
A-3282-J-1024	1	SAE#1, Aluminum-Standard	A-3282-F-1046	1,2
A-3282-K-1025	1	SAE#1, Aluminum-Symmetrical Nodal	A-3282-H-1048	1,2

Section 10

Removing and Installing the Clutch Housing

1. Use Loctite® RTV Sealant™, #5699 (Meritor part number 2297-A-7021) or equivalent, to put a new sealant pattern for the clutch housing on the transmission case. Make sure the sealant is installed in the pattern shown in **Figure 10-3**. See 'Gasket Sealant' in Section 1.
2. Install the clutch housing on the transmission case.
3. Install the mounting nuts and washers on the studs on the clutch housing. Tighten the nuts to 150-190 lb-ft (204-257 N.m). 
4. Apply Loctite® #222 (Meritor part number 2297-B-6112) or equivalent to the threads of the capscrews that fasten the clutch housing to the main case.
5. Install the mounting capscrews and washers and tighten to 65-85 lb-ft (89-115 N.m). 
6. Install the transmission as described in Section 2, "In-Vehicle Service".

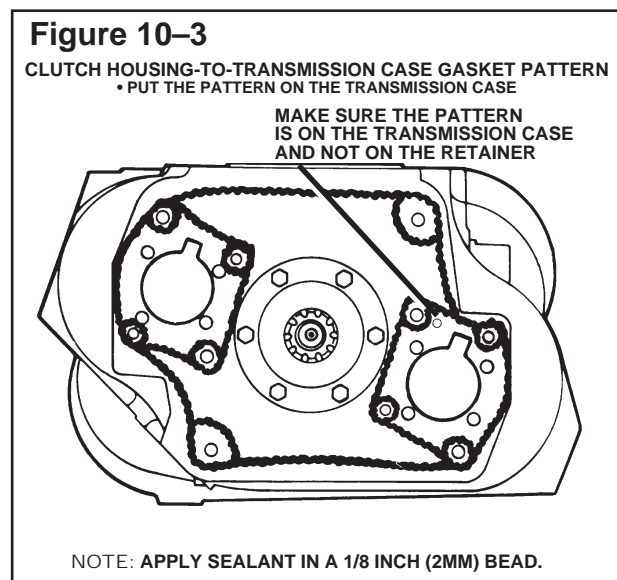



WARNING

To prevent serious eye injury, always wear safe eye protection when doing maintenance or service.

Removing the Auxiliary Case – Nine-Speed and Ten-Speed Transmissions

1. If necessary, remove the transmission and the output yoke as described in this section.

If the auxiliary case is removed with the transmission installed in the vehicle, do the following:

- a. If necessary, remove the output yoke as described in this section.
 - b. Remove the air from the air supply system.
 - c. Put a large container under the transmission. Remove both drain plugs. Drain and discard the oil.
2. Disconnect and mark the air lines. Disconnect the **BLACK** tube from the **LO** range port. On the piston housing cover, disconnect the **BLUE** tube from the **HI** range port. From the supply port of the filter and regulator assembly, disconnect the **RED** tube. **Figure 11-1.**

NOTE:

The auxiliary case must be in the LO range so that the case can be removed.

3. Use an air gun to apply air pressure to the **LO** range port in the piston housing to put the auxiliary case into the **LO** range. If necessary, rotate the output shaft while applying air pressure. **Figure 11-2.**

Figure 11-1

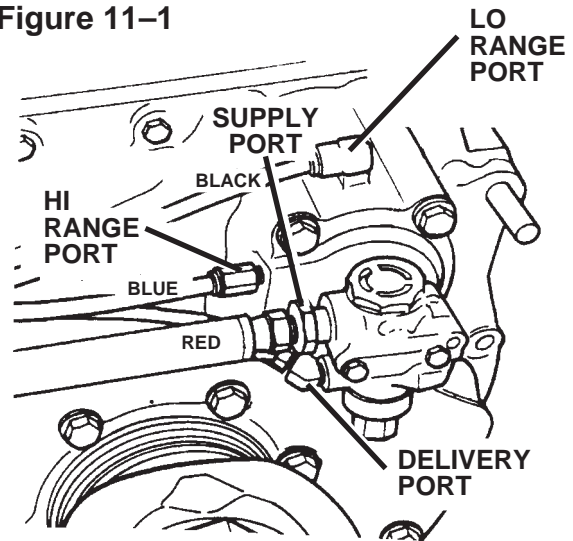
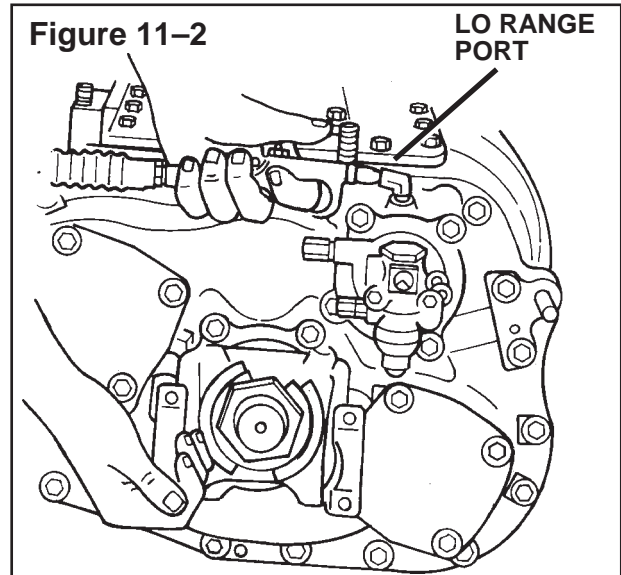

Figure 11-2



4. **On gear driven speedometers,** remove the driven gear from the output bearing retainer and the drive gear from the output shaft.

On electronic speedometers, remove the sensor from the output bearing retainer and the rotor from the output shaft or disconnect the sensor at the connector.

Section 11

Removing and Installing the Auxiliary Case

Nine-Speed and Ten-Speed Transmissions

5. Remove the mounting capscrews and washers from the covers of the auxiliary countershafts. Remove the covers. Use a scraper to remove the gasket material on the cover and the case.



CAUTION

Install holding cover plates or lift brackets on each auxiliary countershaft. If not used, the countershafts will fall when the auxiliary cover is removed.

6. Install Holding Cover Plates, 3305-W-1141 on each counter shaft. See the following. **Figures 11-3 and 11-4.**
 - a. Put the Holding Cover Plate in position on the cover over the countershaft.

NOTE:

One or two holes for the holding cover plate may be in the top of the countershaft.

- b. Rotate the output shaft so that the holes in the countershaft are aligned with the holes in the holding cover plate.
- c. Use capscrews to fasten the cover plates to the countershafts.

NOTE:

Holding cover plate templates are found in Section 20, Specifications. The pattern for the cover plate is shown in Figure 11-4.

Figure 11-3

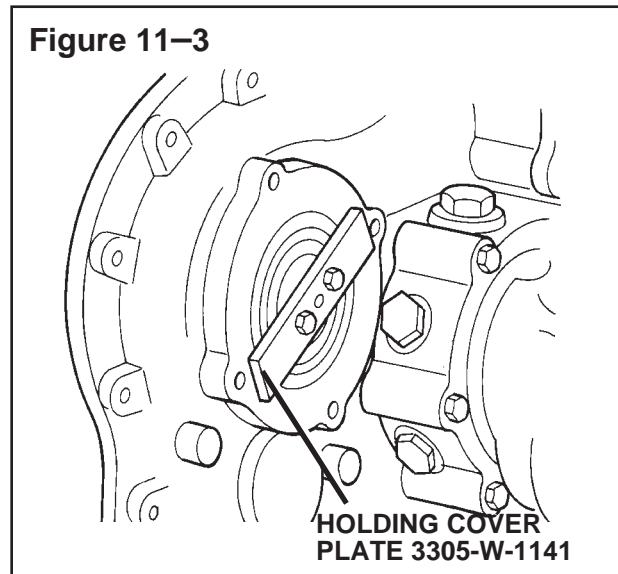
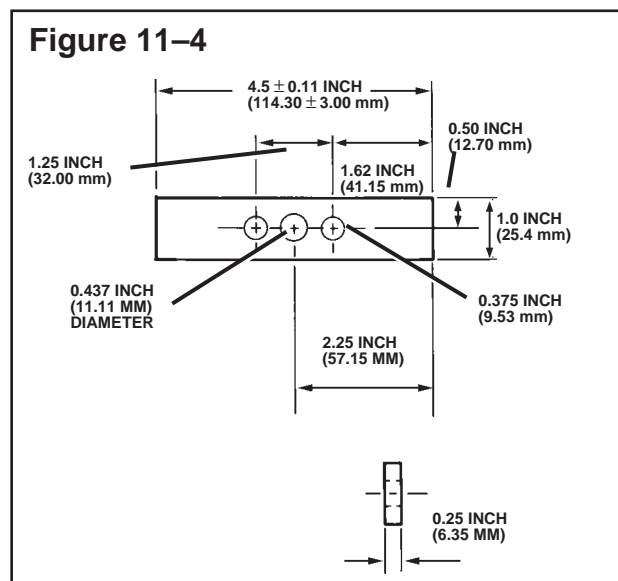

Figure 11-4



Nine-Speed and Ten-Speed Transmissions

Section 11

Removing and Installing the Auxiliary Case

- d. **On Design Level 2 Transmissions only**, install two lifting brackets and two capscrews on each auxiliary countershaft. Install the brackets opposite each other as shown in **Figure 11-5**.

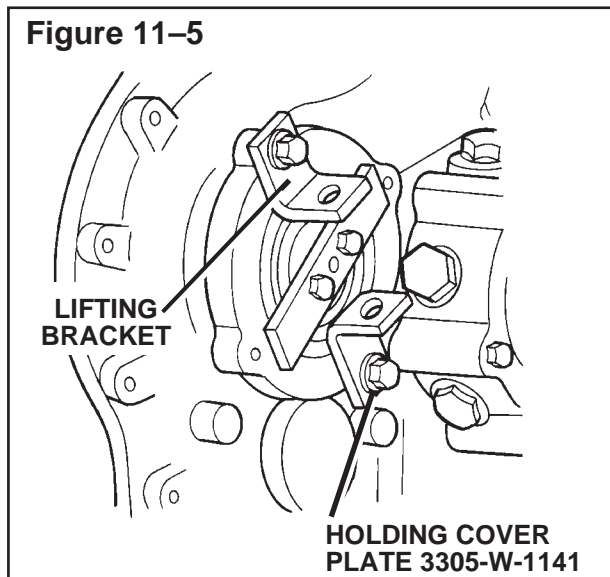

CAUTION

If required, remove the dowel pins from the case side. Do not hit the tapered ends of the dowel pins. If the ends of the dowel pins are damaged, the auxiliary case will be difficult to separate from the main case. Also, the lower dowel pin cannot be removed from the yoke side of the auxiliary case.

7. Clean the dowel pins. Remove paint, rust and dirt from the pins so that the auxiliary case can be removed. Lubricate the dowel pins with new oil that is used in the transmission.

Make sure the dowel pins are not damaged. Replace damaged dowel pins after the auxiliary case is removed.

8. Remove the mounting capscrews and washers from the auxiliary case.
9. Clean the puller holes in the auxiliary case. Install a 3/8"-16 x 1-1/2" UNC capscrew into the three puller holes. Evenly tighten each capscrew to separate the auxiliary case from the transmission case. **Figure 11-6**.

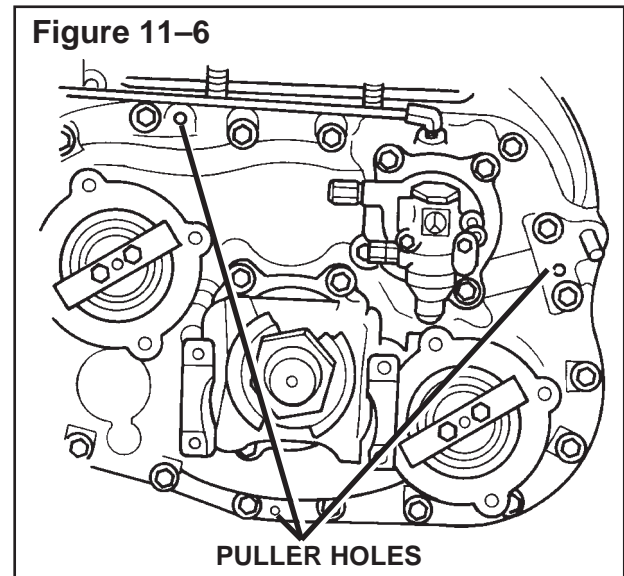

WARNING

When using a hammer and a steel drift, wear safe eye protection and make sure the tools are in safe condition. Do not use tools that are worn or damaged ("mushroomed"). If the tools are not in safe condition, pieces can break and cause serious personal injury.

If the auxiliary case is difficult to remove or the dowel pins are damaged, use a hammer and a steel drift to remove one or both of the pins from the main case. Drive the pins toward the yoke. Make sure the case is securely when the pins are removed.

Section 11 Removing and Installing the Auxiliary Case

Nine-Speed and Ten-Speed Transmissions

10. Remove the puller screws from the auxiliary case.
11. Use an overhead hoist and brackets or a transmission jack and a bracket to remove the auxiliary case from the transmission case. See the following procedure.

Overhead Hoist

- a. Install lifting brackets of the auxiliary case. If necessary, use a pry bar to separate the case from the case enough to install a lifting bracket. **Figure 11-7.**
- b. Connect an overhead hoist to the lifting bracket. **Figure 11-7.**

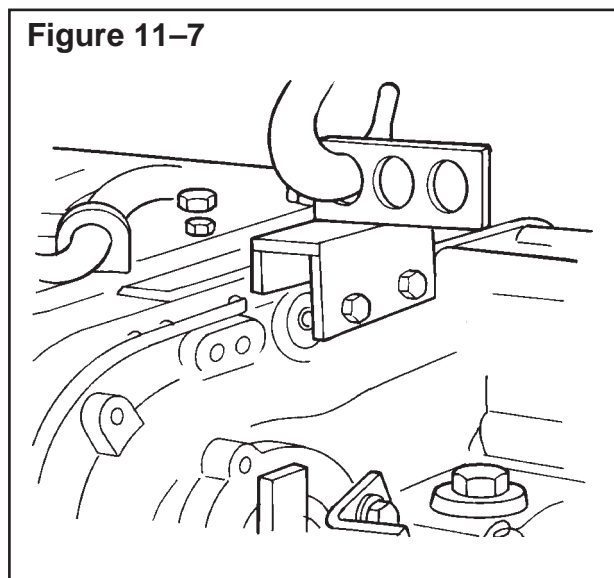

- c. Use an overhead hoist to remove the auxiliary case from the transmission case.

Transmission Jack

- a. Remove the bottom two cap screws from the output bearing retainer. Install a bracket from the transmission jack. **Figure 11-8.**
- b. Connect a transmission jack to the bracket.

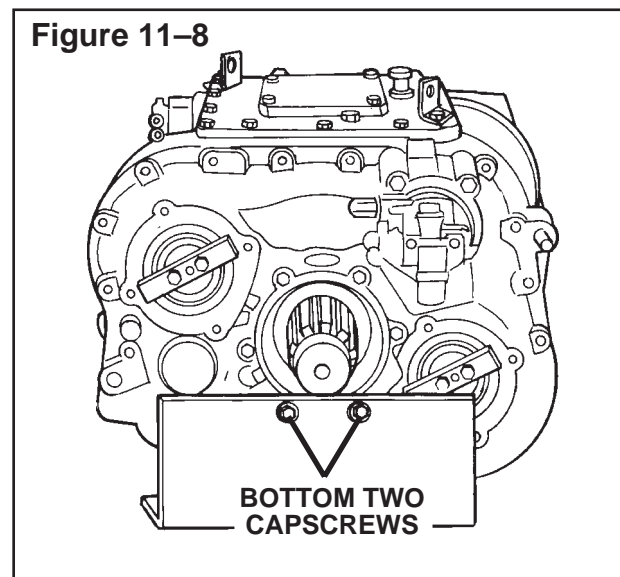

- c. Use the transmission jack to remove the auxiliary case from the transmission case.

NOTE:

Sometimes the bearing cups for the auxiliary countershafts will remain in the bores in the main transmission case. Remove the cups. Mark each cup for the correct location. However, if "slip" fit cups are installed, the cups must be removed and replaced with "press" fit cups.

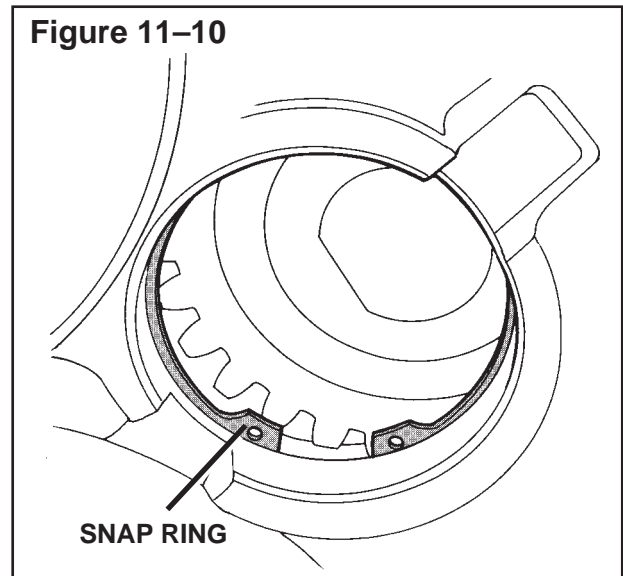
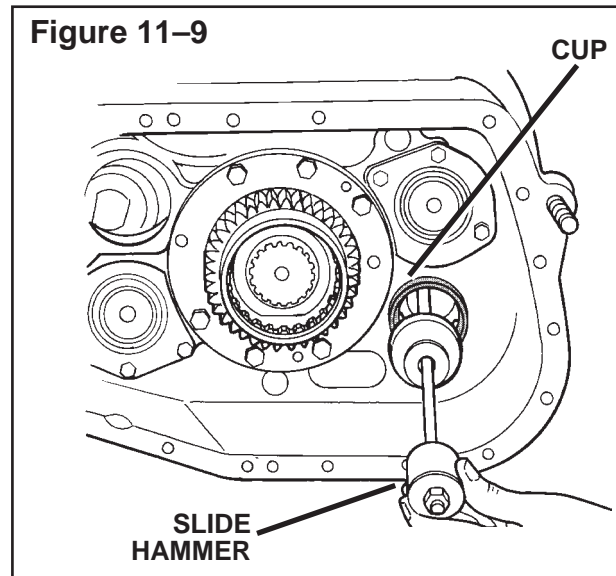

12. Use a slide hammer and a puller to remove the bearing cups for the auxiliary countershaft from the main case. Mark the cups. The cups must be installed in the original location. **Figure 11-9.**
13. **On Design Level 1 Transmissions,** remove the snap rings in the bores for

the cups for the auxiliary countershafts. (**Design Level 2 Transmissions** do not use snap rings in this location.) **Figure 11-10.**

14. Use a scraper to remove the gasket material from the transmission case and the auxiliary case.

Section 11 Removing and Installing the Auxiliary Case

Nine-Speed and Ten-Speed Transmissions

Installing the Auxiliary Case—Nine-Speed and Ten-Speed Transmissions

NOTE:

The auxiliary case must be in the LO range so that the case can be installed with the gears timed correctly.

1. Use an air gun to apply air pressure to the **LO** range port in the piston housing to put the case in the **LO** range.
2. **On Design Level 1 Transmissions**, if removed, install the snap rings in the bores for the cups for the auxiliary countershafts in the main case.

Figure 11-11.

3. If removed, install the bearing cups for the auxiliary countershaft in the bores in the main case. Clean the outer diameter of the cups.

On Design Level 1 Transmissions, make sure the cup is against the snap ring. **Figure 11-11.**

On Design Level 2 Transmissions, make sure the cup is against the step in the bore. **Figure 11-12.**

Figure 11-11

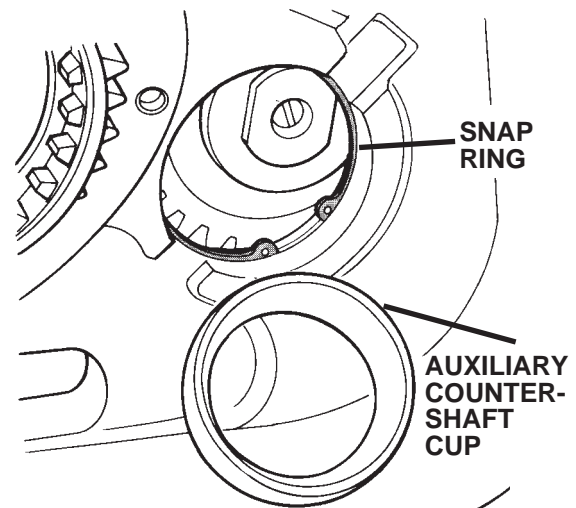

Figure 11-12

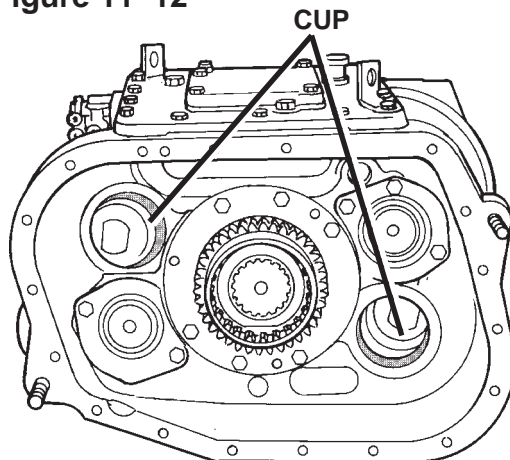
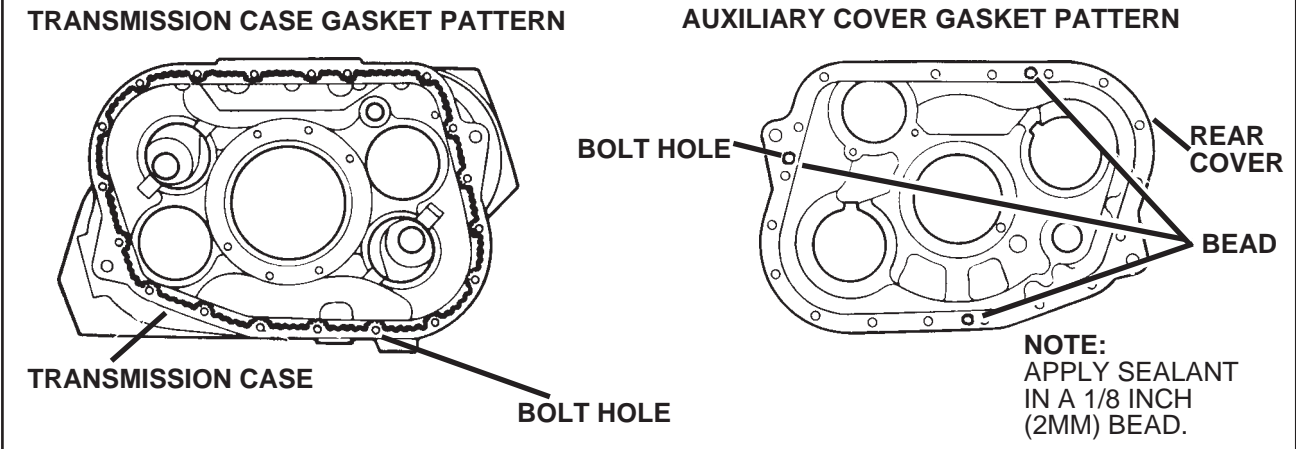

Figure 11-13 AUXILIARY COVER-TO-TRANSMISSION CASE GASKET PATTERN
• PUT THE PATTERN ON THE TRANSMISSION CASE AND THE AUXILIARY COVER



- Use a sealant dispenser and Loctite® RTV Sealant™, #5699 (Meritor Part Number 2297-A-7021) to put a new sealant pattern for the auxiliary case on the transmission case a 1/8 inch (2 mm) bead in the pattern shown in **Figure 11-13**. Put a sealant pattern around each puller hole in the auxiliary case as shown in **Figure 13**. See 'Gasket Sealant' in Section 1.

! WARNING

When using a hammer and a steel drift, wear safe eye protection and make sure the tools are in safe condition. Do not use tools that are worn or damaged ("mushroomed"). If the tools are not in safe condition, pieces can break and cause serious personal injury.

- If the dowels have been removed, use a steel drift and a hammer to install the dowels. Install the dowels from the back of the main case flange. Install the dowels until the end of the dowels are 2.5 inches (64 mm) from the flange. **Figure 11-14**.

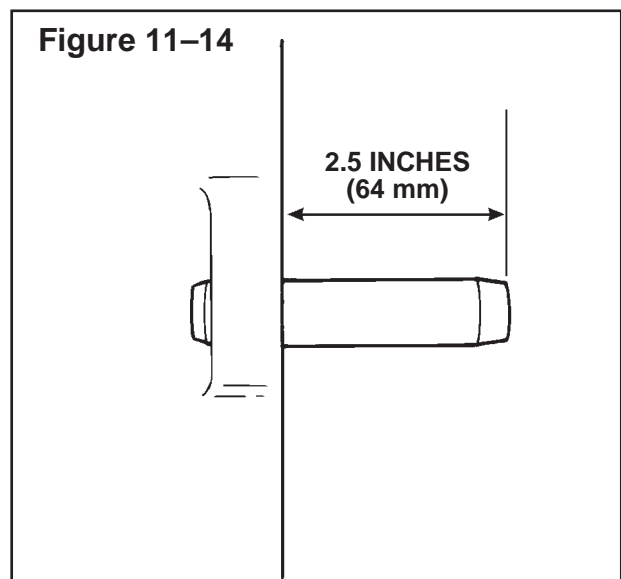

- Lubricate the dowel pins with new oil that is used in the transmission.
- Connect a lifting bracket to the auxiliary case.

If a transmission jack is used, remove the bottom two capscrews from the output bearing retainer. Use capscrews to connect a bracket for the jack to the retainer. **Figure 11-15**.

Section 11 Removing and Installing the Auxiliary Case

Nine-Speed and Ten-Speed Transmissions

Figure 11-15

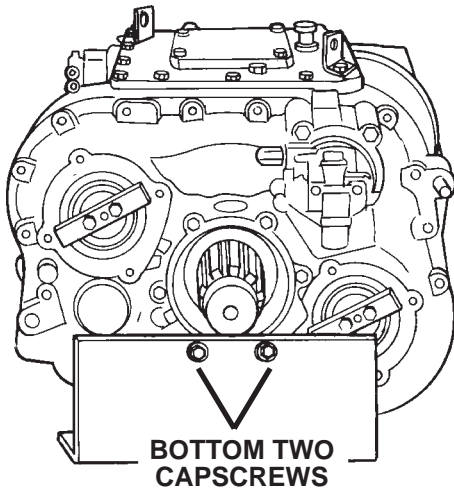

If an overhead hoist is used, connect brackets to the bores for the transmission case cap screws. **Figure 11-16.**

Figure 11-16

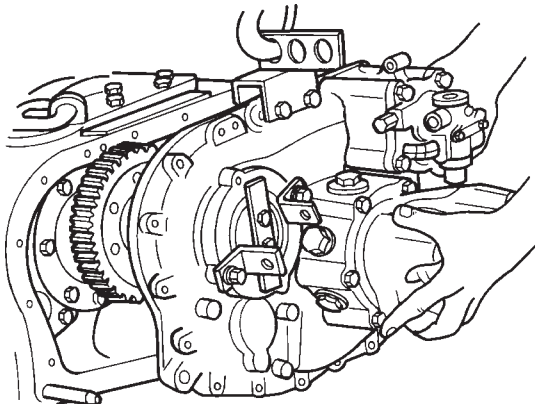

8. Connect a lifting device to the lifting bracket(s).

NOTE:

The auxiliary section must be in the LO range and the main case must be in gear to install the auxiliary case.

9. Install the auxiliary case. Make sure the dowel holes in the auxiliary case are aligned with the dowels in the main case and that the auxiliary case is evenly installed on the dowels. Rotate the input shaft so that the teeth on the auxiliary drive gear align with the teeth on the countershaft driven gears.

Figure 11-17.

Figure 11-17

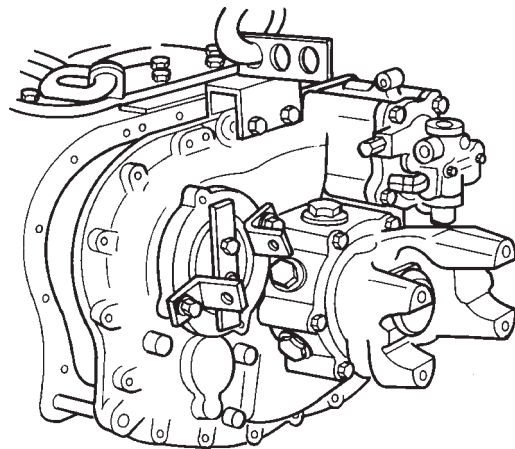

10. Remove the lifting bracket(s) and the lifting device from the auxiliary case.

11. Install the auxiliary case against the transmission case. If necessary, use a rubber or plastic mallet to push the auxiliary case against the main case.

Figure 11-18.

12. Install the mounting cap screws and washers for the auxiliary case. Tighten the cap screws to 35-45 lb-ft (47-61 N.m). **Figure 11-18.**



Figure 11-18

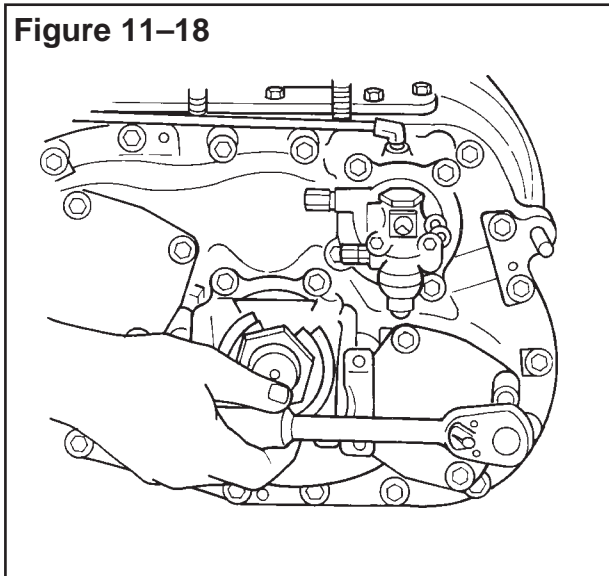

13. Check and adjust the end play of each auxiliary countershaft. Do the procedure described in Section 18, "Auxiliary Countershaft End Play Adjustment". When the correct end play of 0.002-0.006 inch (0.050-0.152 mm) is obtained, go to step 14 of this procedure.
14. If removed, install the filter and regulator assembly. See the procedure described in Section 3, "In-Vehicle Service".

NOTE:

To install the air lines, push the air lines into the fittings until the lines touch the bottom of the fittings. The buttons on

Figure 11-19

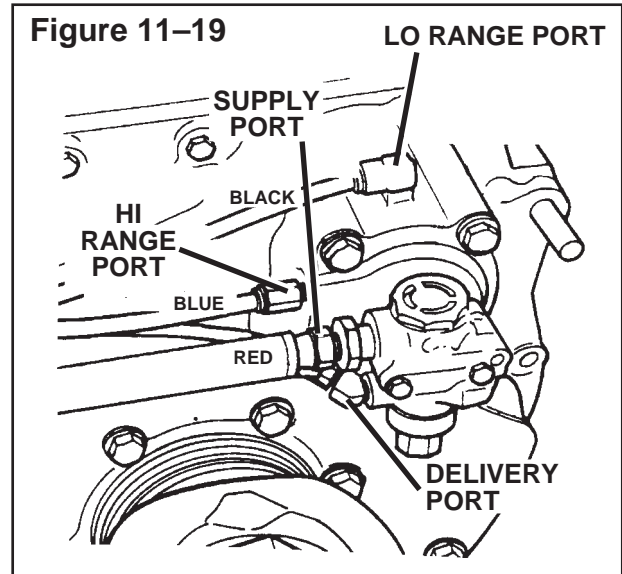

the top of the fittings automatically lock the air lines in position.

15. Connect the **BLUE** air line to the **HI** range port of the piston housing. Connect the **BLACK** air line to the **LO** range port of the piston housing. Connect the **RED** air line to the supply port of the filter and regulator assembly. **Figure 11-19.**
16. Install the transmission as described in Section 4, "Removing and Installing the Transmission".
17. Fill the transmission with the specified oil to the specified level. See "Checking and Adjusting the Oil Level" in Section 2.

Section 11

Removing and Installing the Auxiliary Case

Thirteen-Speed Transmissions

WARNING

To prevent serious eye injury, always wear safe eye protection when doing maintenance or service.

Removing the Auxiliary Case—Thirteen-Speed Transmissions

1. If necessary, remove the transmission and the output yoke as described in this section.

If the auxiliary case is removed with the transmission installed in the vehicle, do the following:

- a. If necessary, remove the output yoke as described in this section.
 - b. Remove the air from the air supply system.
 - c. Put a large container under the transmission. Remove both drain plugs. Drain and discard the oil.
2. Disconnect and mark these air tubes: **Figure 11–20**.
 - a. **BLACK** tube from the **LO** range port on the piston housing.
 - b. **BLUE** tube from the **HI** range port on the piston housing cover.
 - c. **RED** tube from the supply port of the filter and regulator assembly.
 - d. Splitter tube on piston housing cover.

Figure 11–20

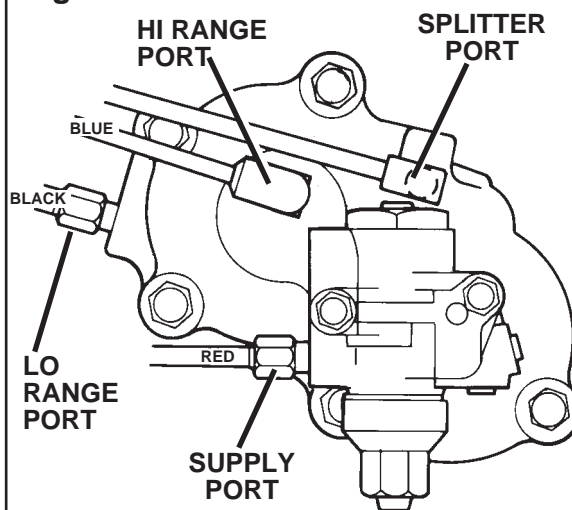

NOTE:

*The auxiliary case must be in the **LO** range so that the case can be removed.*

3. Use an air gun to apply air pressure to the **LO** range port in the piston housing to put the auxiliary case into the **LO** range. If necessary, rotate the output shaft while applying air pressure. **Figure 11–21**.

Figure 11–21

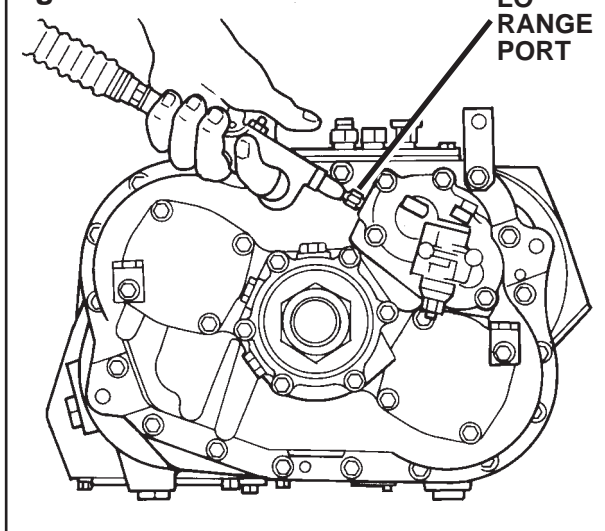

Thirteen-Speed Transmission

Section 11 Removing and Installing the Auxiliary Case

4. On gear driven speedometers, remove the driven gear from the output bearing retainer and the drive gear from the output shaft.

On electronic speedometers, remove the sensor from the output bearing retainer and the rotor from the output shaft or disconnect the sensor at the connector.

5. Remove the mounting capscrews and washers from the covers of the auxiliary countershafts. Remove the covers. Use a scraper to remove the gasket material.

CAUTION

Install Holding Cover Plates on each auxiliary countershaft. If not used, the countershafts will fall when the auxiliary case is removed.

6. Install Holding Cover Plates, 3305-W-1141 on each counter shaft. See the following Figure 11-22.
 - a. Put the Holding Cover Plate in position on the cover over the countershaft.

NOTE:

One or two holes for the holding cover plate may be in the top of the countershaft.

- b. Rotate the output shaft so that the holes in the countershaft are aligned with the holes in the Holding Cover Plate.
- c. Use capscrews to fasten the cover plates to the countershafts and the cover.

NOTE:

Holding Cover Plate templates are found in Section 20, Specifications.

Holding Cover Plates can be made from the pattern shown in Figure 11-23.

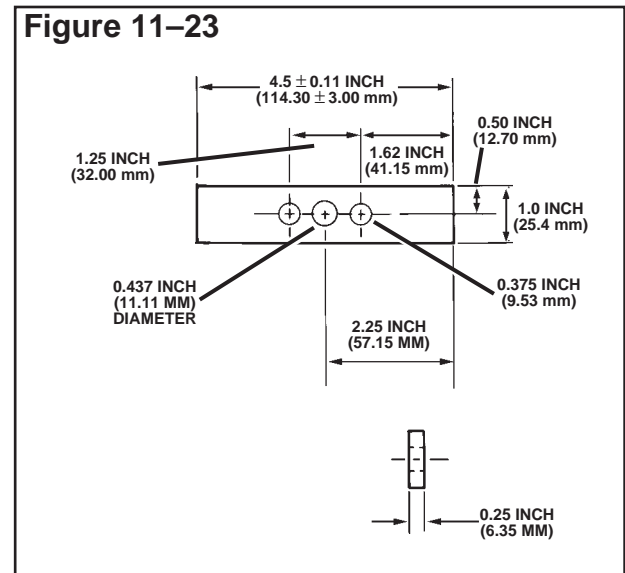
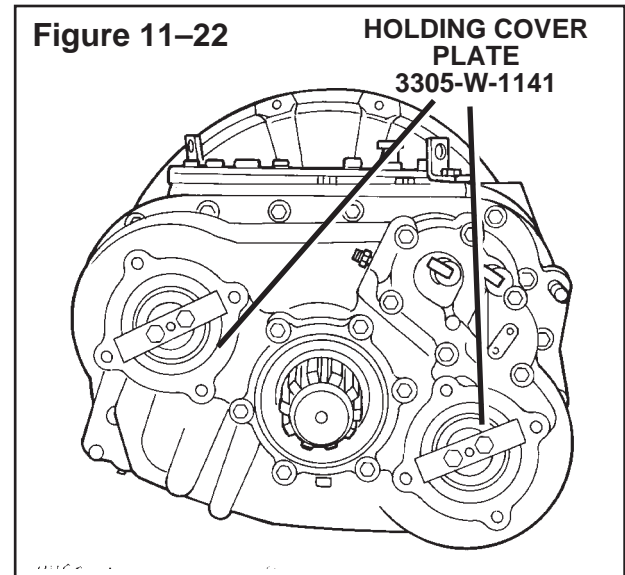

Section 11

Removing and Installing the Auxiliary Case

Thirteen-Speed Transmissions

CAUTION

If required, remove the dowel pins from the case side. Do not hit the ends of the dowel pins. If the ends of the dowel pins are damaged, the auxiliary case will be difficult to separate from the main case. Also, the lower dowel pin cannot be removed from the yoke side of the auxiliary case.

7. Clean the dowel pins. Remove paint, rust and dirt from the pins so that the auxiliary case can be removed. Lubricate the dowel pins with new oil that is used in the transmission.

Make sure the dowel pins are not damaged. Replace damaged dowel pins after the auxiliary case is removed.

8. Remove the mounting capscrews and washers from the auxiliary case.
9. Clean the puller holes in the auxiliary case. Install a 3/8"-16 x 1-1/2" UNC capscrew into the three puller holes. Evenly tighten each capscrew to separate the auxiliary case from the transmission case. **Figure 11-24.**

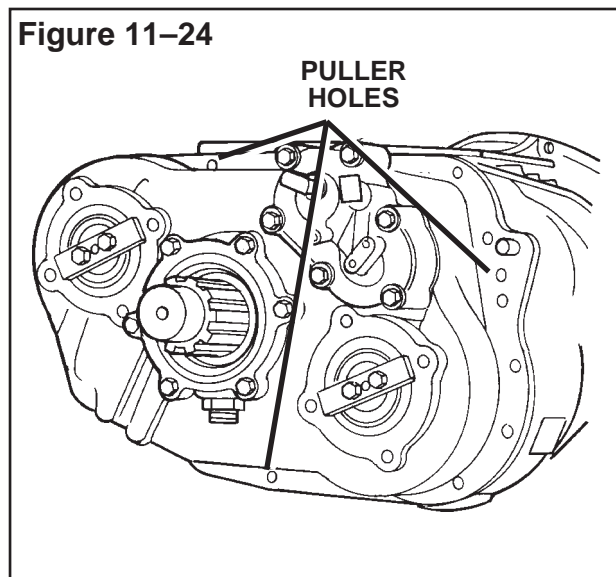

WARNING

When using a hammer and a steel drift, wear safe eye protection and make sure the tools are in safe condition. Do not use tools that are worn or damaged ("mushroomed"). If the tools are not in safe condition, pieces can break and cause serious personal injury.

If the auxiliary case is difficult to remove or the dowel pins are damaged, use a hammer and a steel drift to remove one or both of the pins from the main case. Drive the pins toward the yoke. Make sure the case is secure when the pins are removed.

10. Remove the puller screws from the auxiliary case.
11. Use an overhead hoist and brackets or a transmission jack and a bracket to remove the auxiliary case from the transmission case. See the following procedure.

Overhead Hoist

- a. Install lifting brackets of the auxiliary case. If necessary, use a pry bar to separate the case from the case enough to install a lifting bracket. **Figure 11-25.**
- b. Connect an overhead hoist to the lifting bracket. **Figure 11-25.**
- c. Use an overhead hoist to remove the auxiliary case from the transmission case.

Thirteen-Speed Transmission

Section 11 Removing and Installing the Auxiliary Case

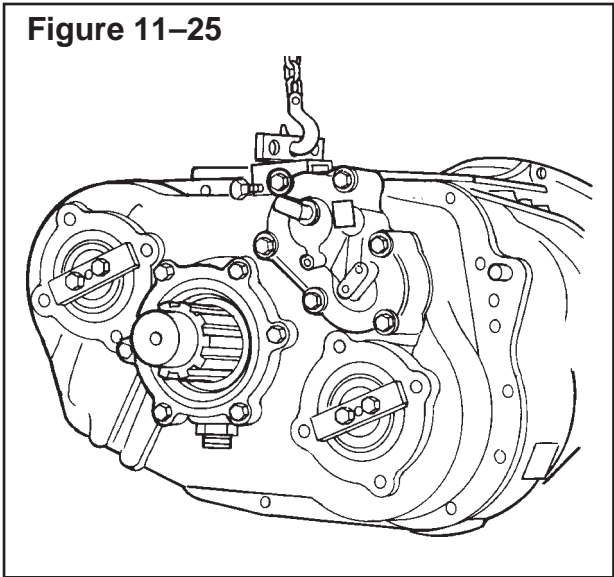

Transmission Jack

- a. Remove the bottom two capscrews from the output bearing retainer. Install a bracket from the transmission jack. **Figure 11-26.**
- b. Connect a transmission jack to the bracket.

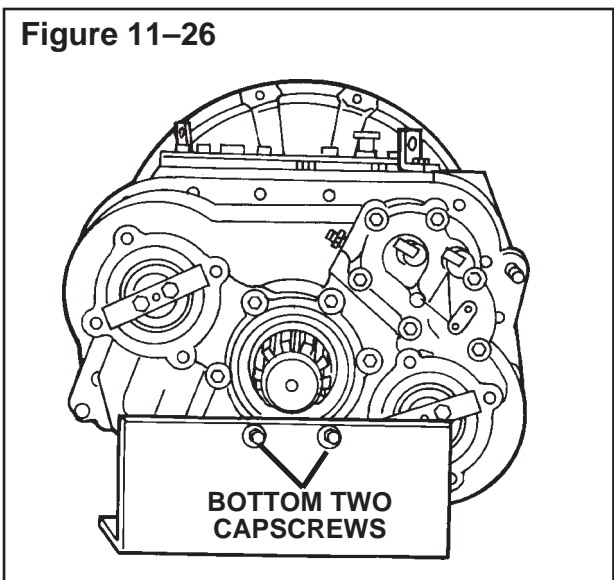

- c. Use the transmission jack to remove the auxiliary case from the transmission case.

NOTE:

Sometimes the bearing cups for the auxiliary countershafts will remain in the bores in the transmission case. Remove the cups. Mark each cup for correct location. However, if “slip” fit cups are installed, the cups must be removed and replaced with “press” fit cups.

- 12. Use a slide hammer and a puller to remove the bearing cups for the auxiliary countershaft from the case. Mark the cups. The cups must be installed in the original location. **Figure 11-27.**

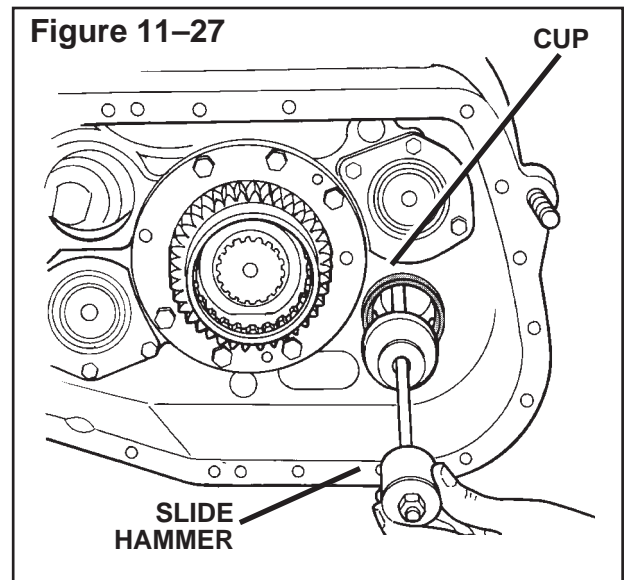

Section 11

Removing and Installing the Auxiliary Case

13. On Design Level 1 Transmissions, remove the snap rings in the bores for the cups for the auxiliary countershafts. (Design Level 2 Transmissions do not use snap rings in this location.) **Figure 11–28.**
14. Use a scraper to remove the gasket material from the transmission case and the auxiliary case.

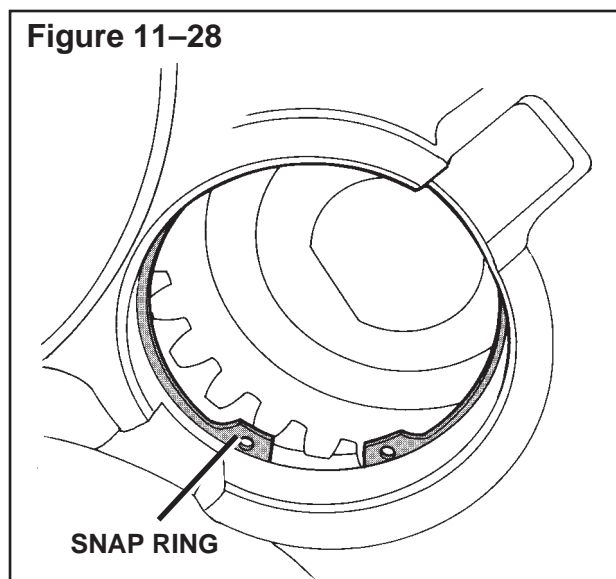

Installing the Auxiliary Case –Thirteen-Speed Transmissions

NOTE:

The auxiliary case must be in the LO range so that the case can be installed with the gears timed correctly.

1. Use an air gun to apply air pressure to the LO range port in the piston housing to put the case in the LO range.
2. On Design Level 1 Transmissions, if removed, install the snap rings in the bores for the cups for the auxiliary countershafts in the main case. **Figure 11–29.**

3. If removed, install the bearing cups for the auxiliary countershaft in the bores in the main case. Clean the outer diameter of the cups.

On Design Level 1 Transmissions, make sure the cup is against the snap ring. **Figure 11–29.**

On Design Level 2 Transmissions, make sure the cup is against the step in the bore. **Figure 11–30.**

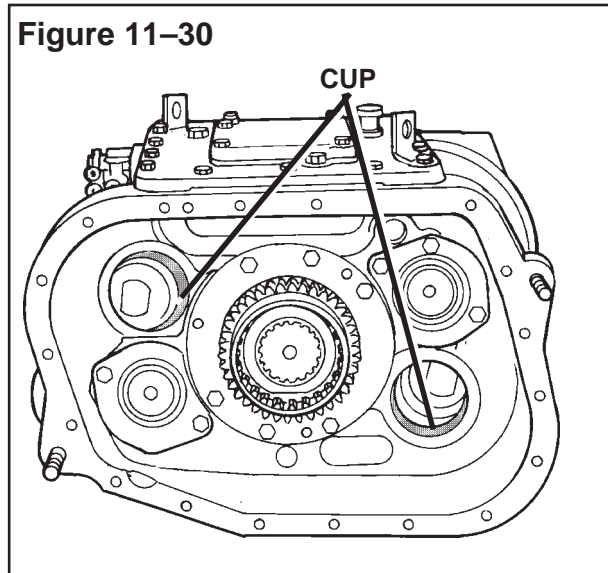
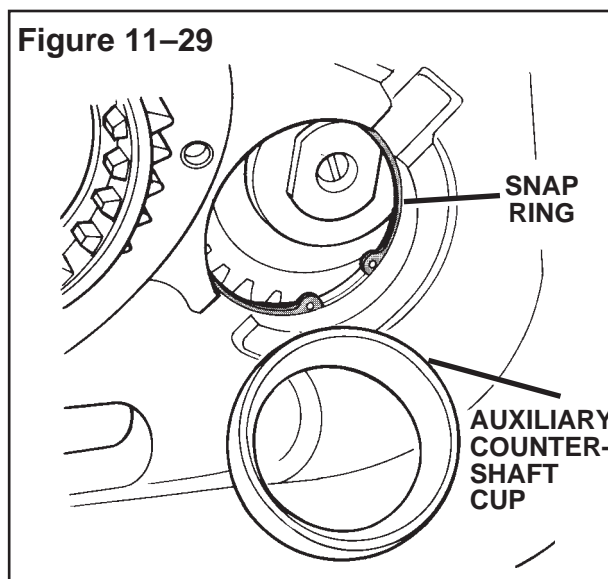

Thirteen-Speed Transmission

Section 11 Removing and Installing the Auxiliary Case

Figure 11-31 AUXILIARY COVER-TO-TRANSMISSION CASE GASKET PATTERN
• PUT THE PATTERN ON THE TRANSMISSION CASE AND THE AUXILIARY COVER

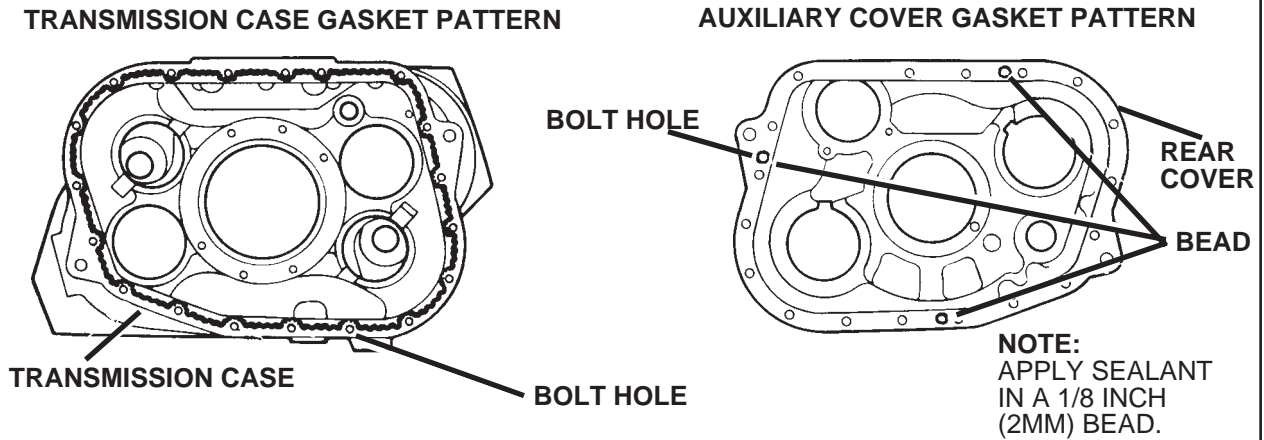

4. Use a sealant dispenser and Loctite® RTV Sealant™, #5699 (Meritor Part Number 2297-A-7021) to put a new sealant pattern for the auxiliary case on the transmission case a 1/8 inch (3 mm) bead in the pattern shown in **Figure 11-31**. Put a sealant pattern around each puller hole in the auxiliary case as shown in **Figure 11-31**. See 'Gasket Sealant' in Section 1.

! WARNING

When using a hammer and a steel drift, wear safe eye protection and make sure the tools are in safe condition. Do not use tools that are worn or damaged ("mushroomed"). If the tools are not in safe condition, pieces can break and cause serious personal injury.

5. If the dowels have been removed, use a steel drift and a hammer to install the dowels. Install the dowels from the back of the main case flange. Install the dowels until the end of the dowels are 2.5 inches (64 mm) from the flange. **Figure 11-32**.

Figure 11-32

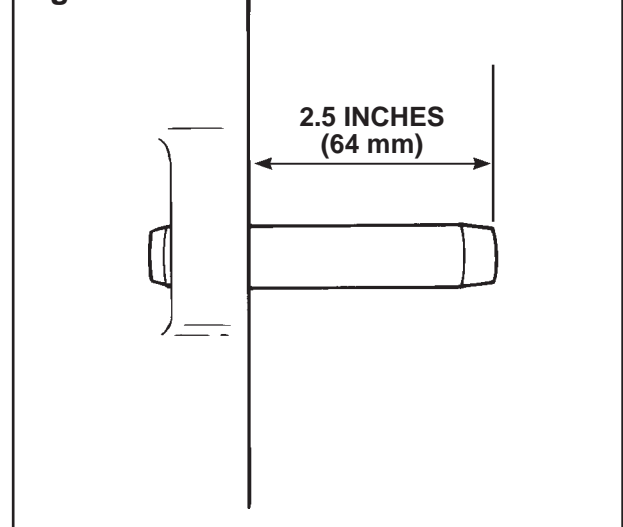

6. Lubricate the dowel pins with new oil that is used in the transmission.
7. Connect a lifting bracket to the auxiliary case.

If a transmission jack is used, remove the bottom two capscrews from the output bearing retainer. Use capscrews to connect a bracket for the jack to the retainer. **Figure 11-33**.

Section 11

Removing and Installing the Auxiliary Case

Thirteen-Speed Transmissions

Figure 11-33

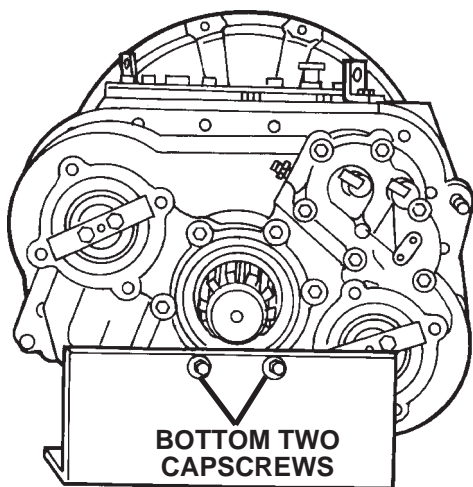

If an overhead hoist is used, connect brackets to the bores for the transmission case cap screws. **Figure 11-34.**

Figure 11-34

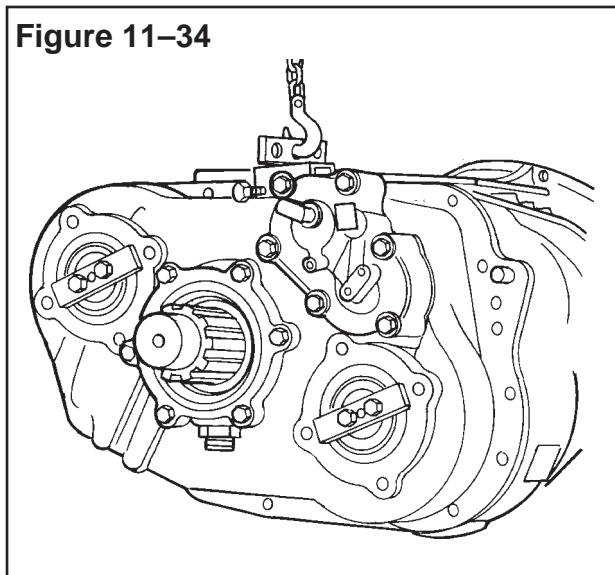

8. Connect a lifting device to the lifting bracket(s).

NOTE:

The auxiliary section must be in the LO range to install the auxiliary case.

9. Install the auxiliary case. Make sure the dowel holes in the auxiliary case are aligned with the dowels in the main case and that the auxiliary case is evenly installed on the dowels. Rotate the input shaft so that the teeth on the auxiliary drive gear align with the teeth on the countershaft driven gears.

Figure 11-35.

Figure 11-35

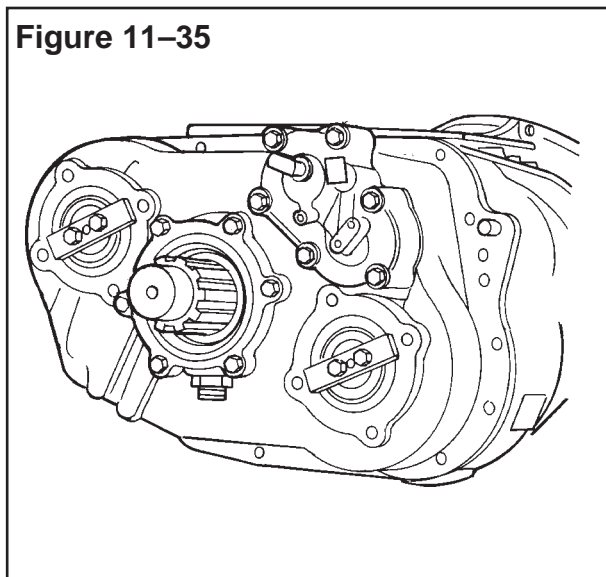

10. Remove the lifting bracket(s) and the lifting device from the auxiliary case.
 11. Install the auxiliary case against the transmission case. If necessary, use a rubber or plastic mallet to tap the auxiliary case against the main case.
- Figure 11-36.**
12. Install the mounting cap screws and washers for the auxiliary case. Tighten the cap screws to 35-45 lb-ft (47-61 N.m). **Figure 11-36.**



Thirteen-Speed Transmission

Section 11 Removing and Installing the Auxiliary Case

Figure 11-36

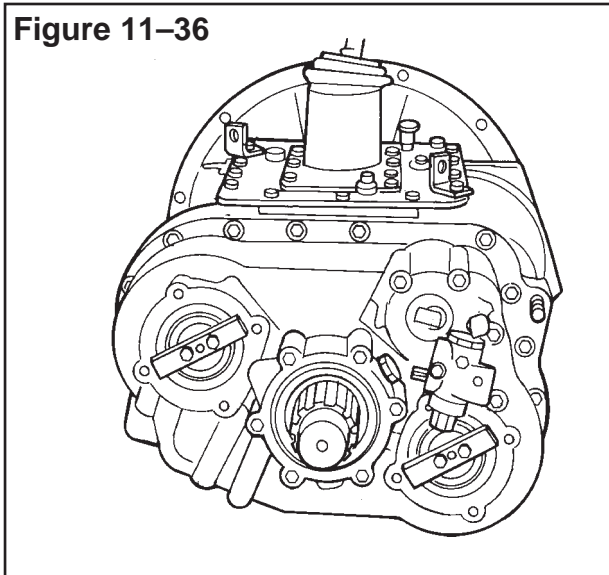

13. Check and adjust the end play of each auxiliary countershaft. Do the procedure described in Section 18, "Auxiliary Countershaft End Play Adjustment". When the correct end play of 0.002-0.006 inch (0.050-0.152 mm) is obtained, go to step 14 of this procedure.
14. If removed, install the filter and regulator assembly. See the procedure in Section 3, "In-Vehicle Service".

NOTE:

To install the air lines, push the air lines into the fitting until the lines touch the bottom of the fittings. The buttons on the top of the fittings automatically lock the air lines in position.

Figure 11-37

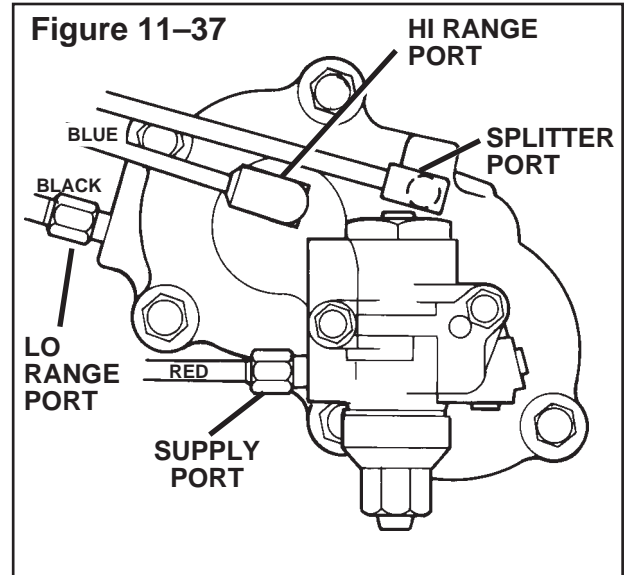

15. Connect the following air tubes: **Figure 11-37**.
 - a. **BLACK** tube to the **LO** range port on the piston housing.
 - b. **BLUE** tube to the **HI** range port on the piston housing cover.
 - c. **RED** tube to the supply port of the filter and regulator assembly.
 - d. Splitter tube to the fitting on the piston housing cover.
16. Install the transmission as described in this section.
17. Fill the transmission with the specified oil to the specified level. See "Checking and Adjusting the Oil Level" in Section 2.

Section 11

Removing and Installing the Auxiliary Case

All Transmissions

Removing the Auxiliary Drive Gear

1. Remove and discard the snap ring that fastens the auxiliary drive gear to the mainshaft. **Figure 11-38.**
2. Use pry bars to separate the auxiliary drive gear from the mainshaft. Remove the gear. **Figure 11-39.**
3. Remove and discard the two O-rings from the gear. **Figure 11-40.**

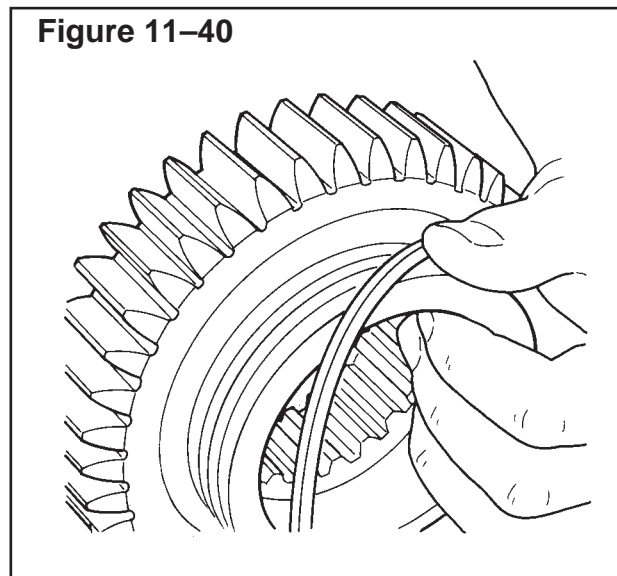
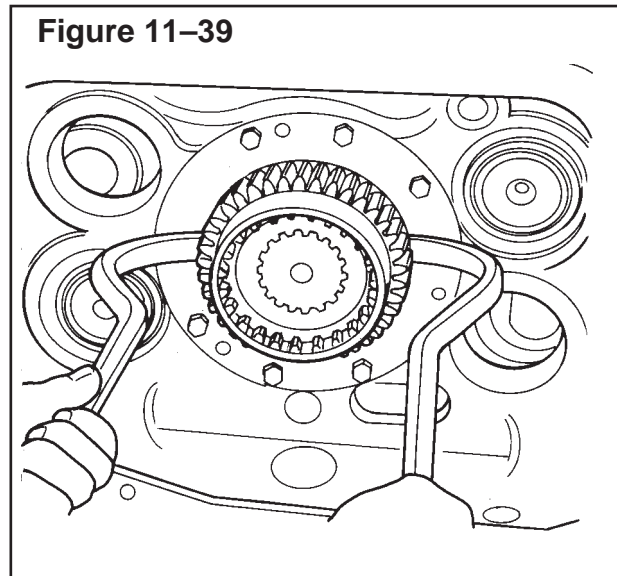
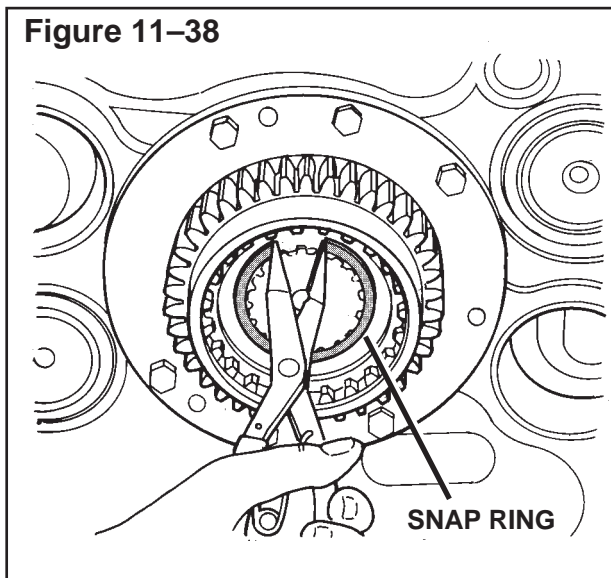

Installing the Auxiliary Drive Gear

1. Lubricate all parts with new oil that is used in the transmission.
2. Lubricate new O-rings with new oil that is used in the transmission. Install new O-rings on the gear.
3. Install the auxiliary drive gear assembly on the mainshaft and in the rear of the case. **Figure 11-41.**
4. Install a new snap ring that fastens the auxiliary drive gear on the mainshaft. **Figure 11-42.**

Figure 11-41

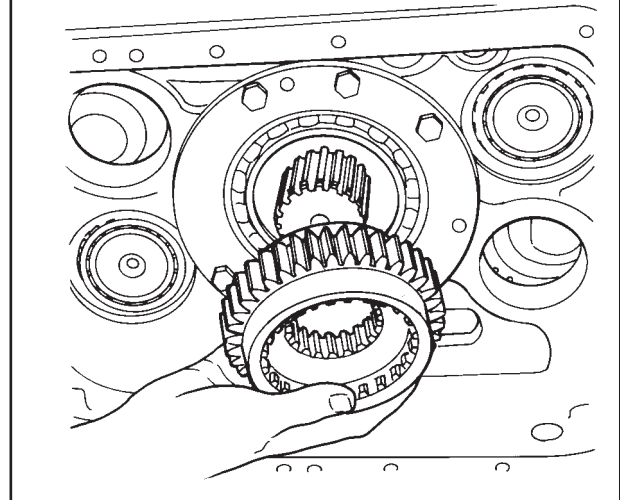
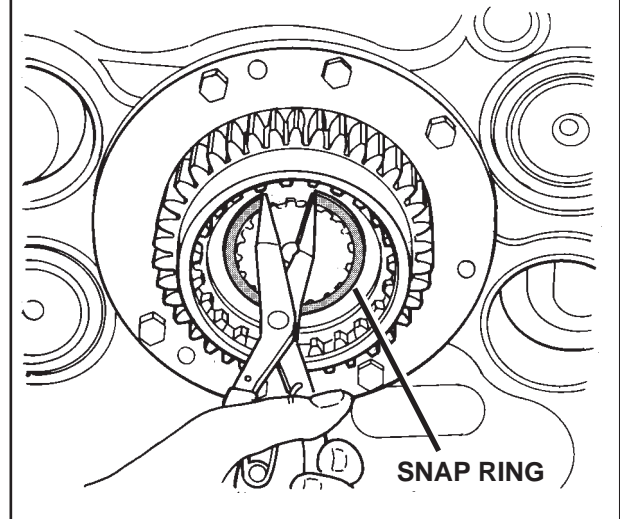

Figure 11-42



Section 12

Overhauling the Main Case



WARNING

To prevent serious eye injury, always wear safe eye protection when doing maintenance or service.

Removing the Mainshaft

NOTE:

If the auxiliary drive gear is removed, go to step 5.

- 1 Remove the capscrews that fasten the bearing retainer of the auxiliary drive gear to the transmission case. **Figure 12-1.**
2. Remove and discard the snap ring that fastens the auxiliary drive gear to the mainshaft. **Figure 12-1.**

Figure 12-1

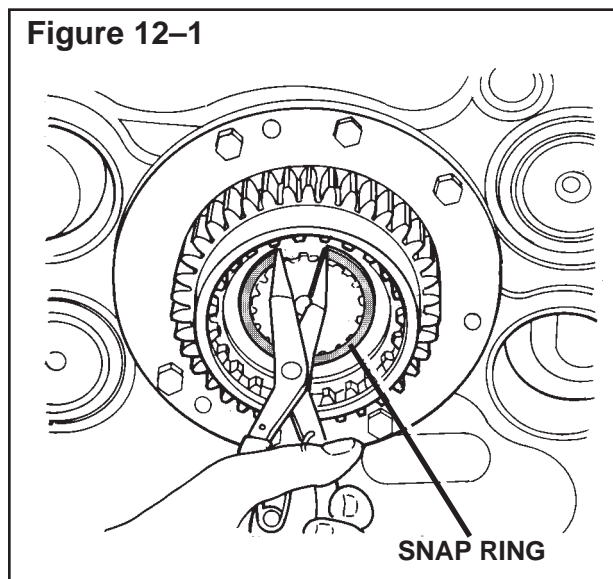

3. If a two-piece retainer is used for the auxiliary drive gear, use pry bars to separate the auxiliary drive gear from the mainshaft. Remove the gear. Remove and discard the O-rings from the gear. Remove the two-piece retainer **Figure 12-2.**

Figure 12-2

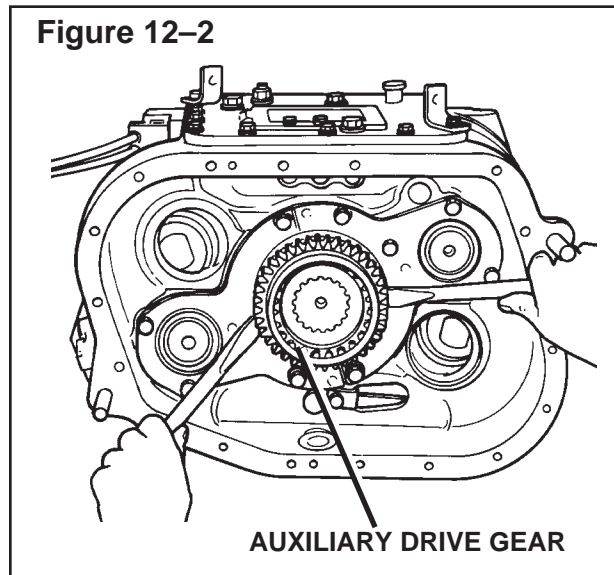

3. If a round retainer is used for the auxiliary drive gear, clean the puller holes and install a 3/8"-16 x 1.00" capscrew in the three puller holes in the bearing retainer of the auxiliary drive gear. Evenly tighten the three capscrews to remove the auxiliary drive gear from the mainshaft. If necessary, tap on the mainshaft with a rubber or plastic mallet to separate the gear from the mainshaft. Remove the round retainer. **Figure 12-3.**

Figure 12-3

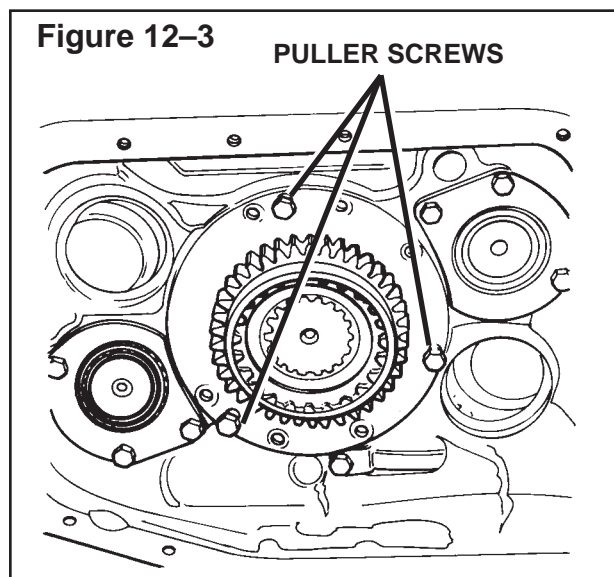

Section 12 Overhauling the Main Case

NOTE:

The ball bearing assembly for the auxiliary drive gear will sometimes come out when the auxiliary drive gear is removed. If necessary, pull on the assembly to separate the gear from the bearing.

4. Put a pry bar under the snap ring on the ball bearing assembly for the auxiliary drive gear. Remove the bearing. **Figure 12-4.**

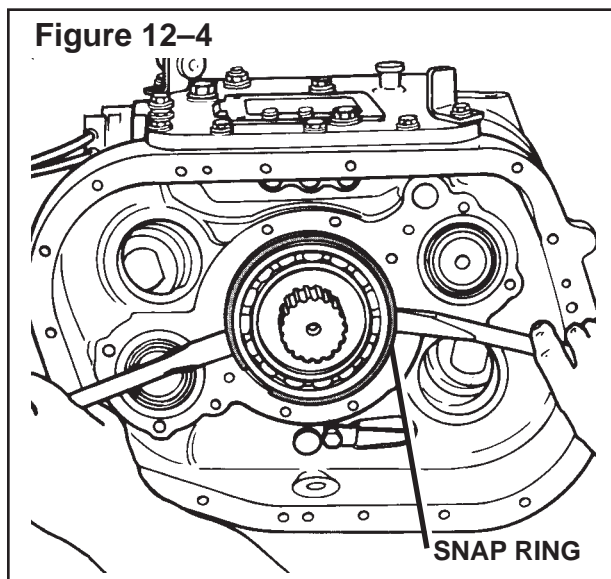

5. Remove the auxiliary drive gear thrust washer from the mainshaft. **Figure 12-5.**
6. Remove the snap ring from the reverse gear on the mainshaft. **Figure 12-6.**
7. Slide the clutch collar into the low or first gear. Move the reverse gear against the low or first gear. **Figure 12-7.**

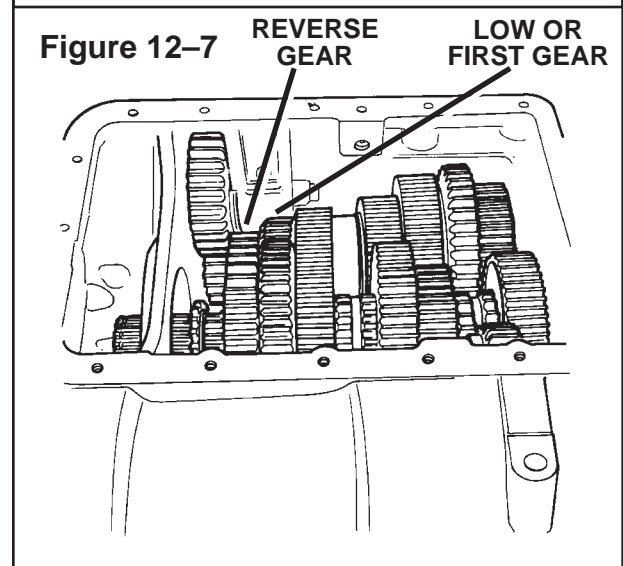
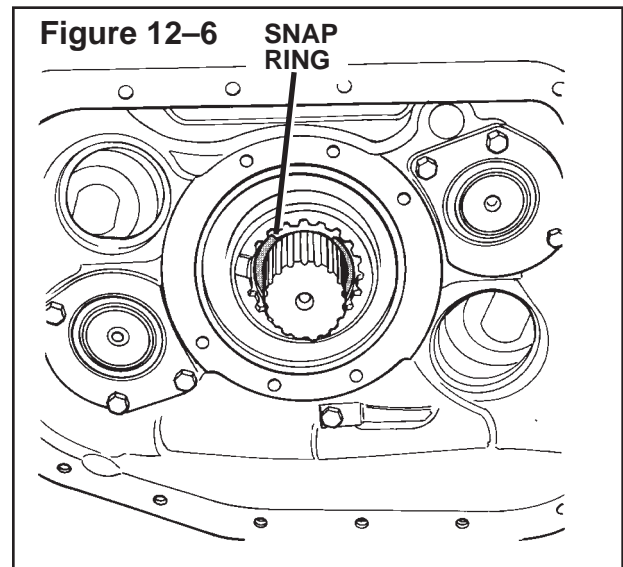
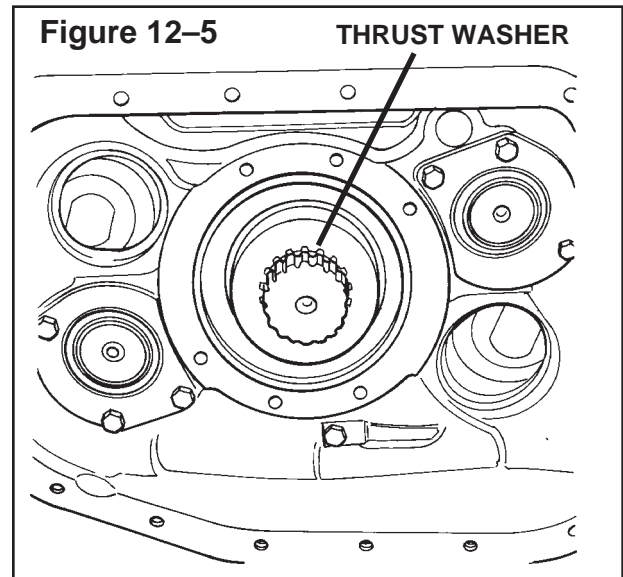

Section 12

Overhauling the Main Case

- Put a pry bar between the case and the end of the idler shaft to keep the reverse idler shaft for the upper countershaft from moving. Remove the nut and the washer that fastens the gear on the shaft. **Figure 12-8.**

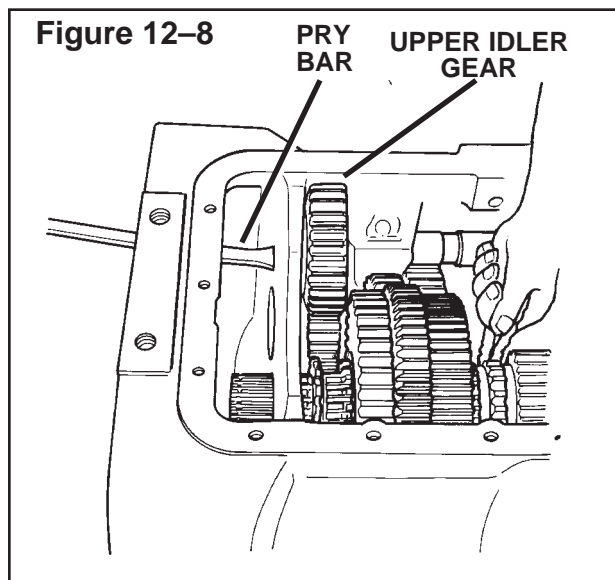

- Remove the upper reverse idler shaft from the rear of the case. Remove the reverse idler gear, the two spacer washers, the bearing race and the needle bearing assembly while removing the shaft. **Figure 12-9.**

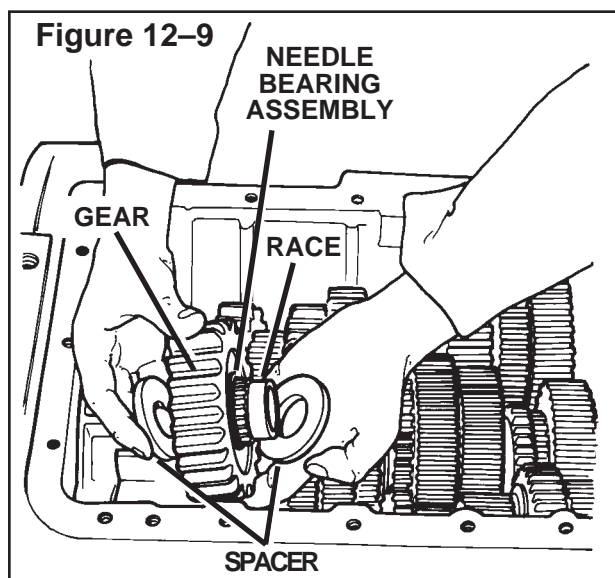

! CAUTION

The mainshaft must be supported when the countershaft is serviced. If not supported, the timing marks fall out of alignment. The weight of the mainshaft will also damage the thrust washers between the gears.

- Install the auxiliary drive gear and bearing assembly so that the mainshaft is supported in the case.
- On Design Level 1 Transmissions,** remove the selective snap ring for the front upper countershaft bearings in the case. Mark the snap ring for correct installation. **Figure 12-10.**

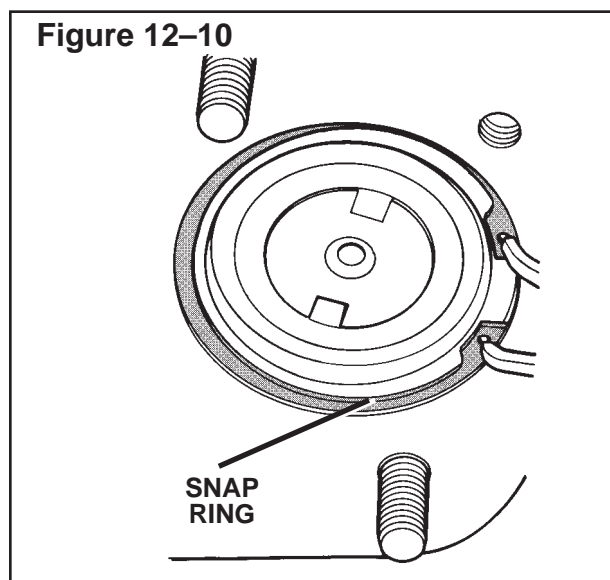

- On Design Level 2 Transmissions,** remove the Allen-head screws that fasten the front upper countershaft retainer to the case. Remove the retainer and the shims. **Figure 12-11.**

Section 12 Overhauling the Main Case

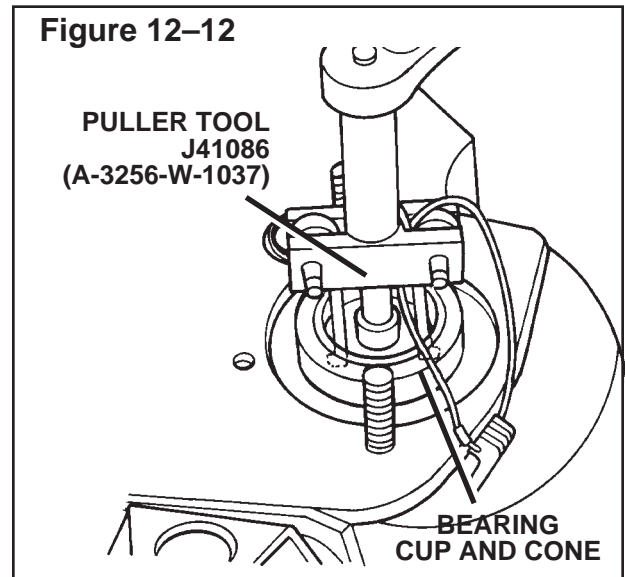
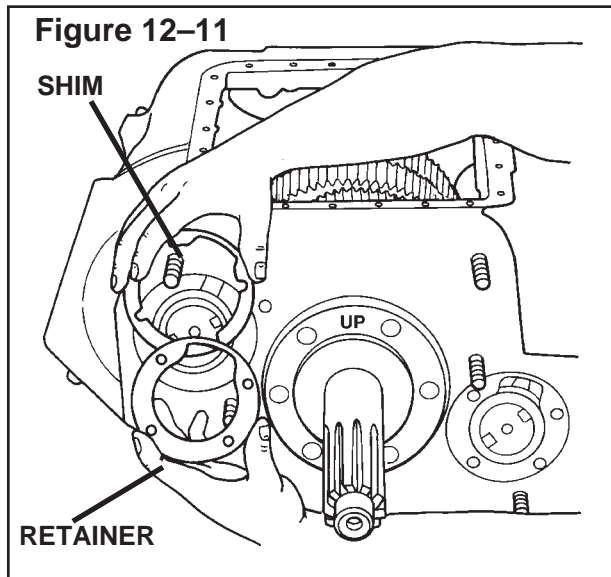

CAUTION

Use hand tools to rotate the forcing screw of the bearing puller tool. If power tools are used, the tool will be damaged.

13. Remove the front upper countershaft bearing cup and cone. Use Bearing Puller Tool, Meritor Part Number A-3256-W-1037, or Kent-Moore Number, J-41086 or equivalent to remove the cup and cone. Make sure the correct keys of the tool for transmission design level are installed between the jaws of the puller and the countershaft.

Figure 12-12.

If the cup is removed easily, the cup is a “loose” fit cup. Discard and replace with a “press” fit cup and cone assembly. Make sure the correct parts are used.

14. **On Design Level 1 Transmissions,** remove the selective snap ring for the rear upper countershaft bearing in the case. Mark the snap ring for correct installation. **Figure 12-13.**

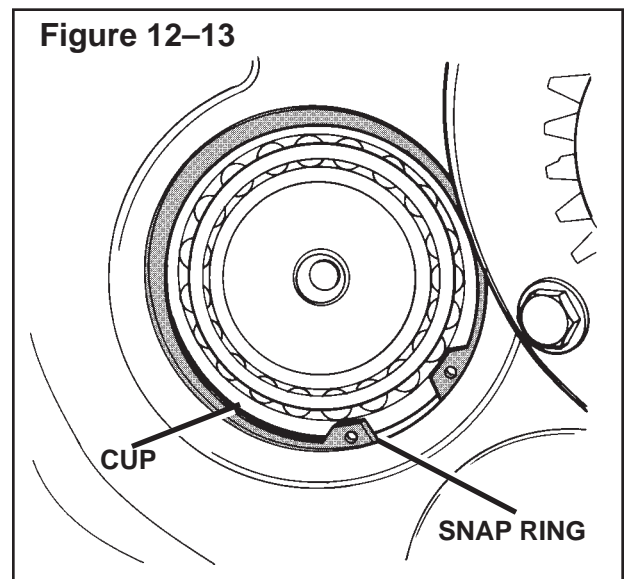

NOTE:

Two types of rear countershaft bearing retainers are used on Design Level 2 transmissions. One retainer is used on transmissions with serial numbers LB93017865 and below. The other retainer is used on transmissions with serial numbers LB93017866 and above. Make sure the correct part is used.

Section 12

Overhauling the Main Case

15. On Design Level 2 Transmissions, remove the fasteners for the rear upper countershaft retainer. Remove the retainer. **Figure 12-14.**

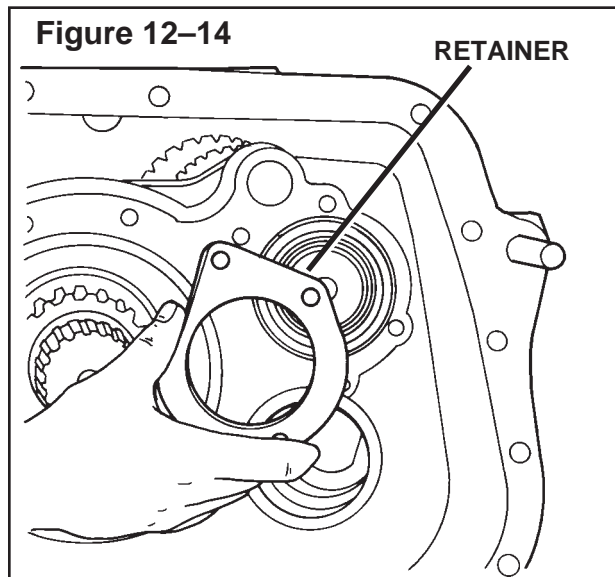

CAUTION

Use hand tools to rotate the forcing screw of the countershaft bearing pusher tool. If power tools are used, the tool will be damaged.

16. Install Countershaft Bearing Pusher Tool, Meritor Part Number 3256-D-1044 or G&W Tool Number G-28 or equivalent, on the front of the countershaft. Rotate the forcing screw until the rear countershaft bearing cup can be removed from the case. Make sure the countershaft does not push against the mainshaft. **Figure 12-15.**

If the cup is removed easily, the cup is a “loose” fit cup. Discard and replace with a “press” fit cup and cone assembly. Make sure the correct part is used.

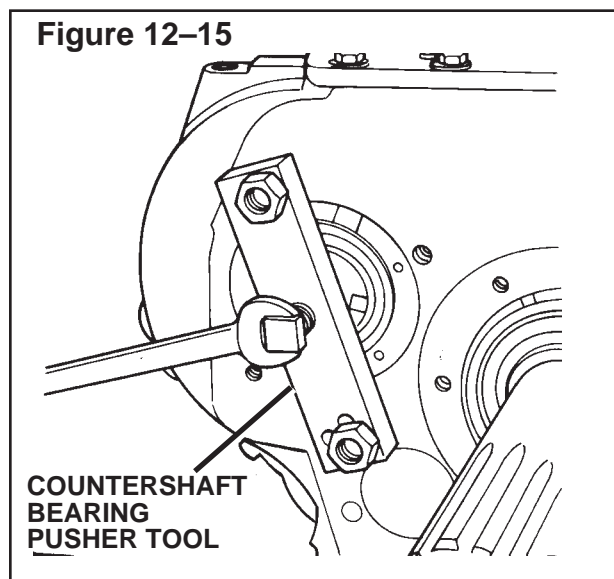

17. Move the upper countershaft assembly forward and to the side of the case. Make sure the countershaft is separated from the mainshaft assembly.
18. Remove the auxiliary drive gear from the mainshaft.
19. Remove the mainshaft. See the following procedure.
- Make sure the reverse gear is against the low gear.

WARNING

The mainshaft assembly weighs more than 50 pounds. Use a lifting device to install the mainshaft into the case to avoid serious personal injury.

- Put a rope or a lifting hook under the first-second collar. Slide the mainshaft assembly to the rear of the case. **Figure 12-16.**

Section 12

Overhauling the Main Case

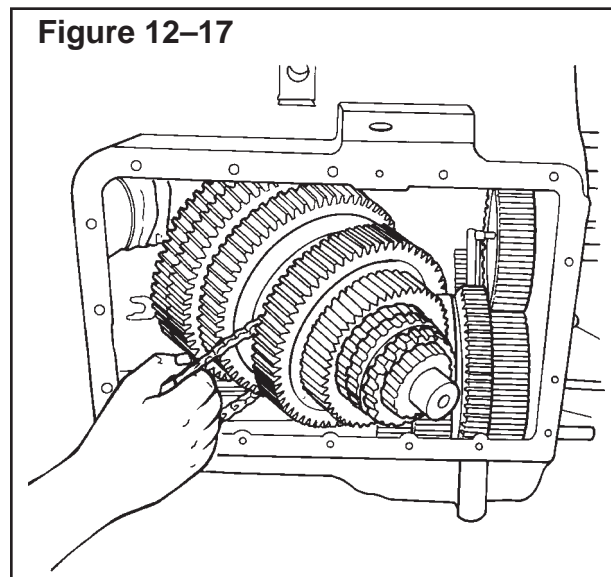
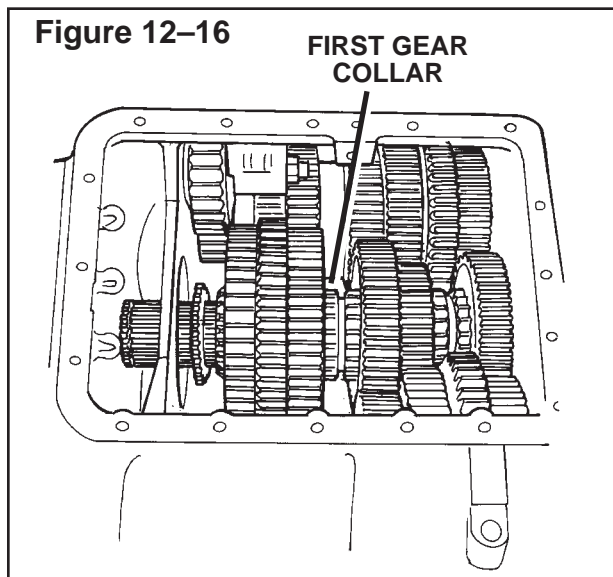

CAUTION

Hold the reverse gear when removing the mainshaft. If not secured, the gear can fall from the shaft.

- c. Tilt the front of the mainshaft up and lift the mainshaft assembly from the case. **Figure 12-17.**

Section 12

Overhauling the Main Case

Removing the Input Shaft

The top cover, the mainshaft and the auxiliary drive gear must be removed to remove the input shaft.

1. Remove the mounting capscrews and washers from the input bearing retainer. Remove the retainer.

Figure 12-18.

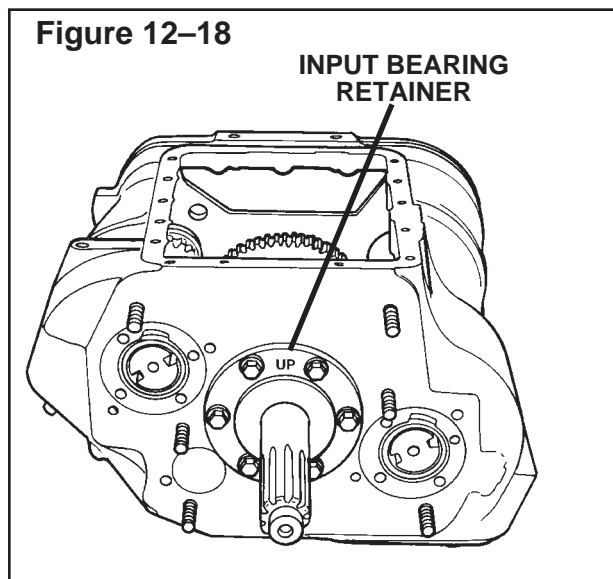

2. Use a scraper to remove the sealant material from the transmission case and the input bearing retainer.
3. Remove the input shaft. See the correct procedure.

Design Level 1 Transmissions

- a. Remove the snap ring on the outer race of the input bearing.

Figure 12-19.

- b. Use a rubber mallet to drive the input shaft, the bearing assembly and the main drive gear from the case. **Figure 12-20.**

Figure 12-19

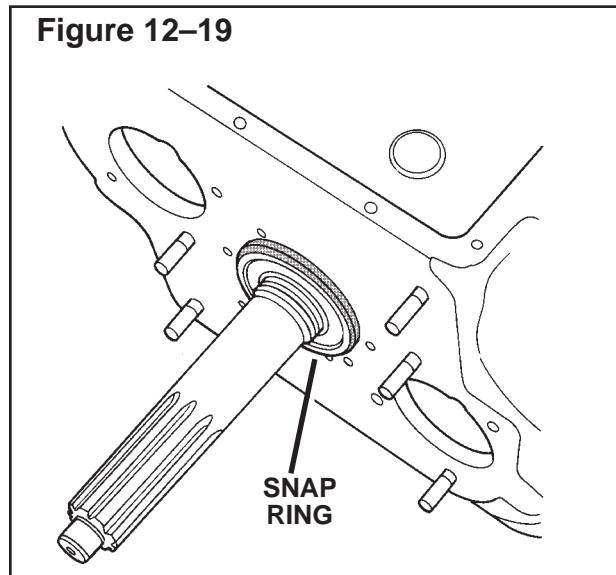
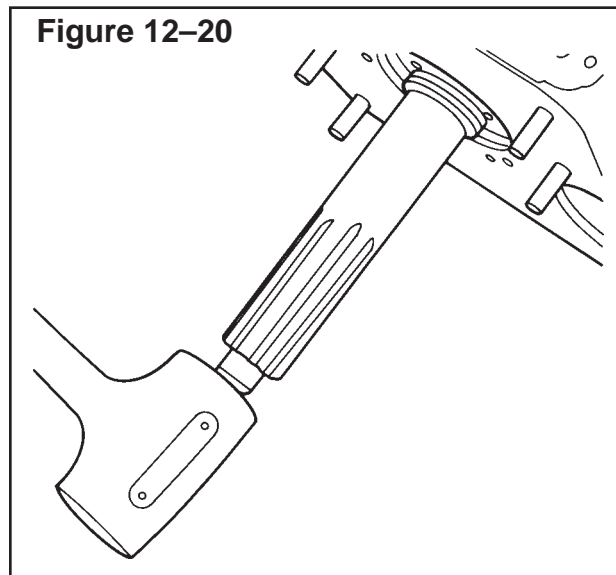

Figure 12-20



- c. If necessary, disassemble the input shaft assembly as described in step 4.

Design Level 2 Transmissions

- a. Remove the snap ring that retains the input shaft in the bearing. **Figure 12-21.**

Section 12 Overhauling the Main Case

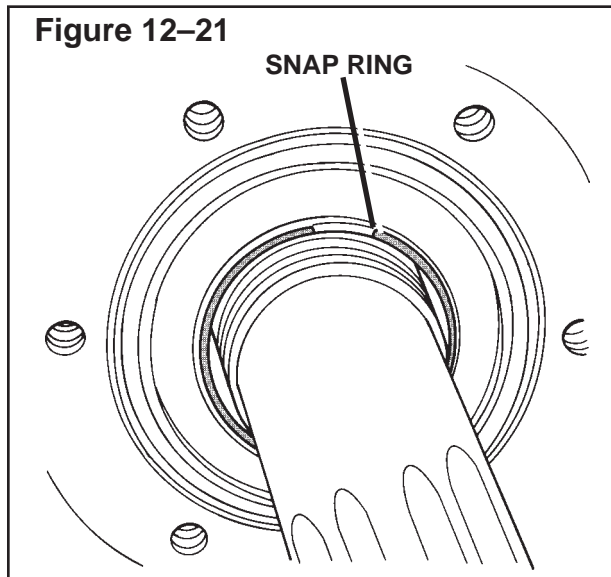

- b. Remove the input shaft from the case. If necessary, use a rubber mallet to drive the input shaft from the case. **Figure 12-22.**

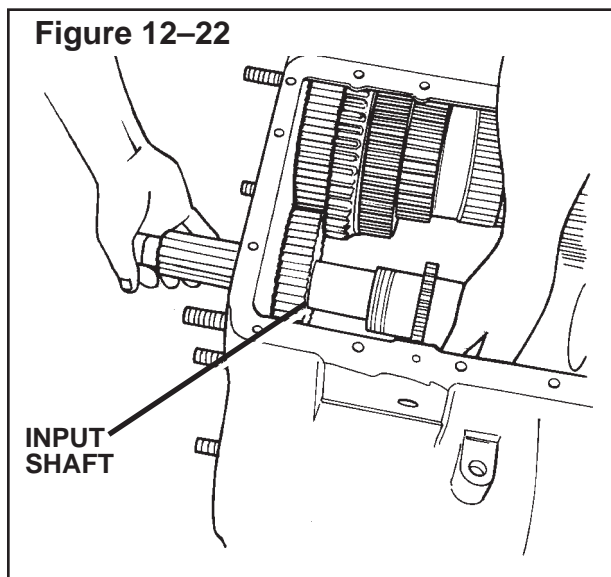

- c. Remove the input bearing from the case. If necessary, remove the snap ring from the bearing. **Figure 12-23.**

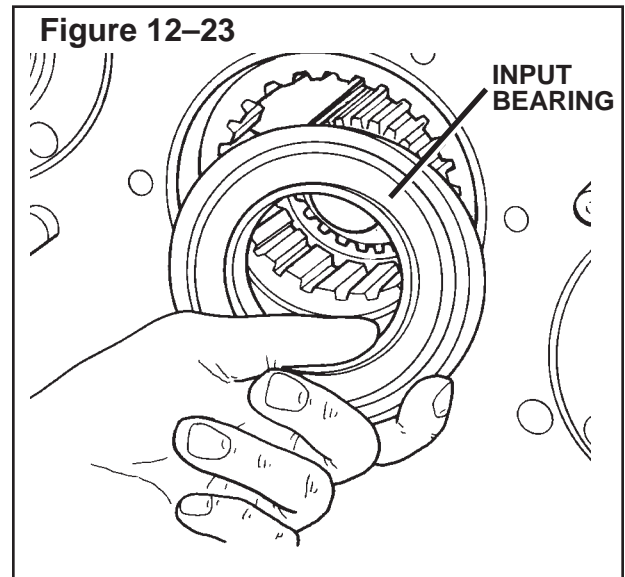

- d. Remove the main drive gear and the spacer from the case.

Figure 12-24.

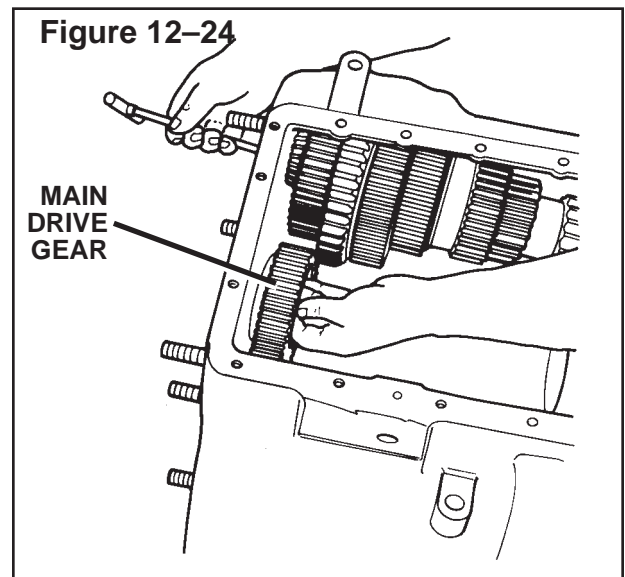

4. On Design Level 1 Transmissions, if required, disassemble the input shaft. See the following procedure.

Figure 12-25.

Section 12

Overhauling the Main Case

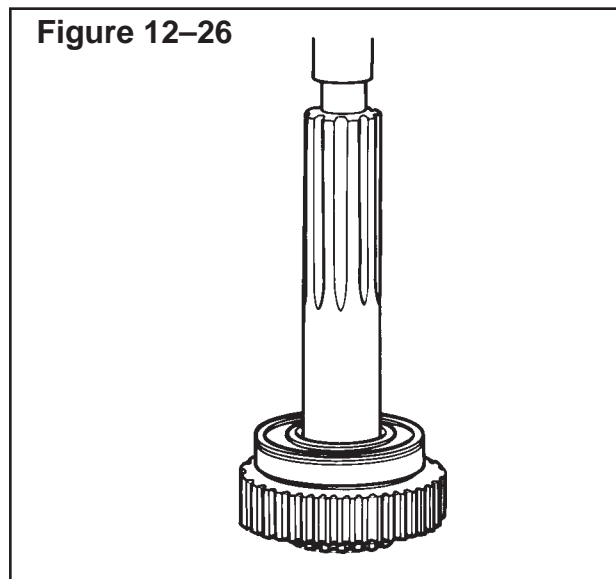
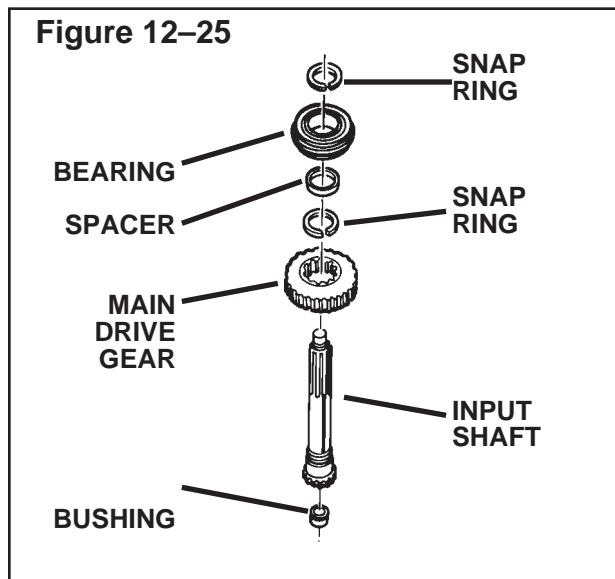

- a. Remove the snap ring from the side of the input bearing.
- b. Use a press and a sleeve to remove the input shaft from the bearing. **Figure 12-26.**
- c. Remove the spacer from the top of the gear.
- d. Remove the input shaft from the main drive gear. Remove the snap ring from the groove inside the main drive gear.
- e. If worn or damaged, use a puller tool to remove the bushing from inside the input shaft.
- f. Inspect all parts. See "Inspecting the Parts" in Section 1.

Removing the Main Countershafts

1. Remove the auxiliary drive gear and mainshaft as described in this section. See “Removing the Mainshaft”.
2. Remove the input shaft and the main drive as described in this section. See “Removing the Input Shaft”.
3. If installed, remove the long capscrews or the T-Handle Tools (3256-Y-1013) from the countershafts.
4. Push the countershaft assemblies to the rear of the case. Tilt the front of the countershaft up and remove the countershaft. Remove the upper and lower countershafts from the case. Mark the countershafts for correct installation. **Figure 12-27.**

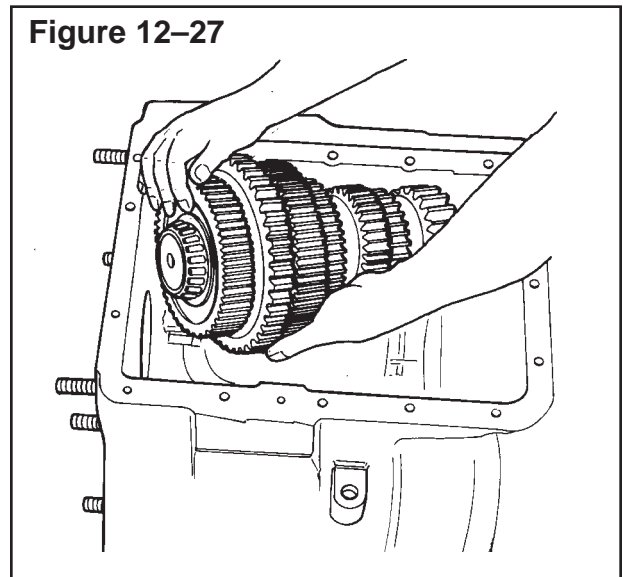

Section 12

Overhauling the Main Case

Removing the Reverse Idler Gear Assembly

1. Remove the upper reverse idler gear assembly and the mainshaft as described in "Removing the Mainshaft" in this section.
2. Remove the input shaft as described in "Removing the Input Shaft" in this section.
3. Remove the main countershafts as described in "Removing the Main Countershafts" in this section.
4. Put a pry bar between the case and the end of the idler shaft to keep the lower reverse idler shaft from moving. Remove the nut and the washer that fastens the gear on the shaft. **Figure 12-28.**
5. Remove the reverse idler gear, the two spacer washers, the bearing race and the needle bearing assembly while removing the shaft. **Figure 12-29.**

Figure 12-28

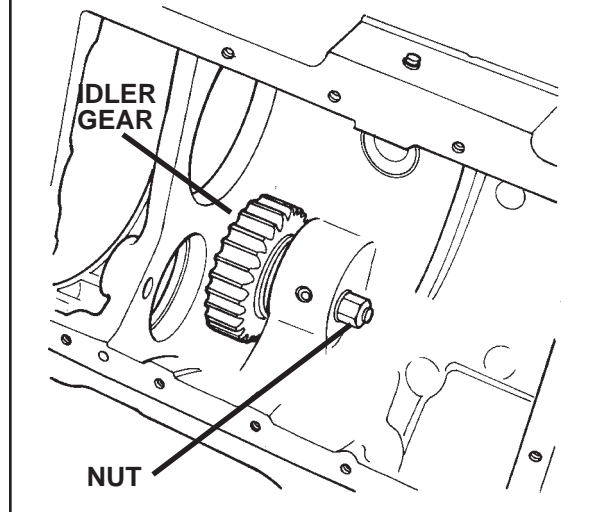
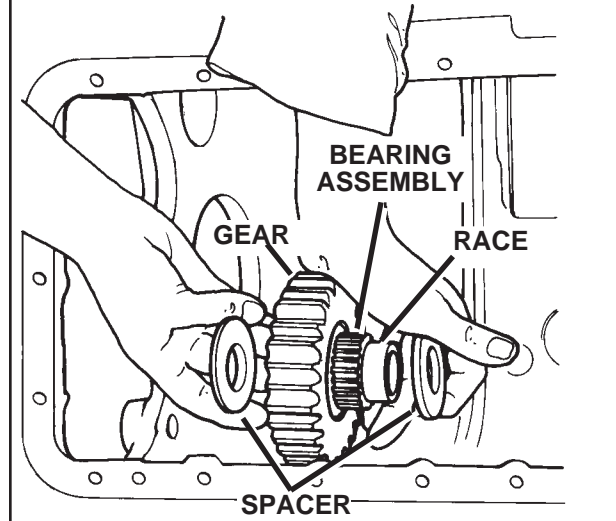

Figure 12-29



Removing the Oil Pump

1. Remove the auxiliary drive gear, the mainshaft, the input shaft and the countershafts as described in this section.
2. Remove the Allen-head capscrews and washers that fasten the pump to the case. **Figure 12-30.**
3. Remove the bracket for the pick-up tube from the case.
4. Remove the pump. If necessary, hit the pump with a plastic or rubber hammer to separate the pump from the case.
5. Clean the pick-up screen on the tube. If the tube or screen is damaged, replace the pick-up tube assembly.
6. If used, inspect the pump-to-case O-ring on the front of the pump. If worn or damaged, replace the O-ring.
7. Remove the cover and inspect the pump. Replace the O-ring if worn or damaged. Replace the pump if the rotors are worn or damaged. **Figure 12-31.**

Figure 12-30

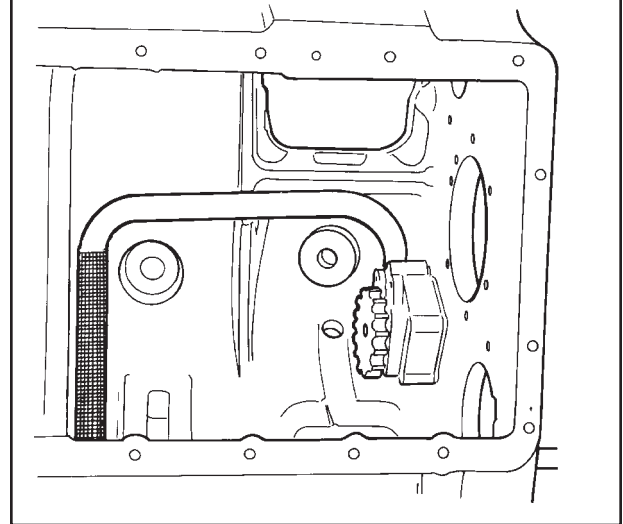
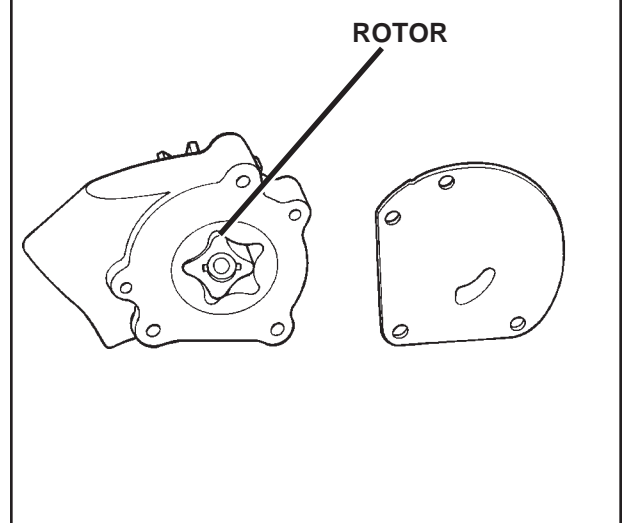

Figure 12-31



Section 12

Overhauling the Main Case

Removing the Magnets

1. Remove the auxiliary drive gear, the mainshaft, the input shaft and the countershafts as described in this section.
2. Remove the magnets from the bottom of the case. **Figure 12-32.**

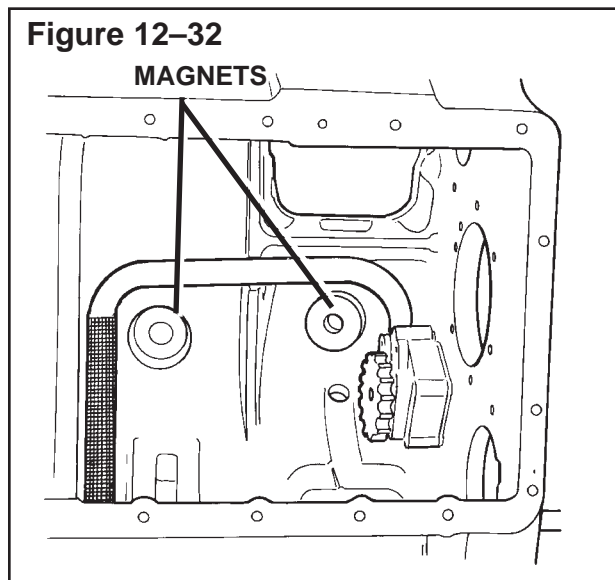

Removing the PTO Covers

1. Drain the lubricant from the transmission. See "Draining and Replacing the Transmission Oil" in Section 2, "Lubrication and Maintenance".
2. Remove the capscrews that fasten the PTO covers to the side and the bottom of the case. Remove the covers. **Figure 12-33.**
3. Use a scraper to remove the sealant material from the PTO covers and the case.

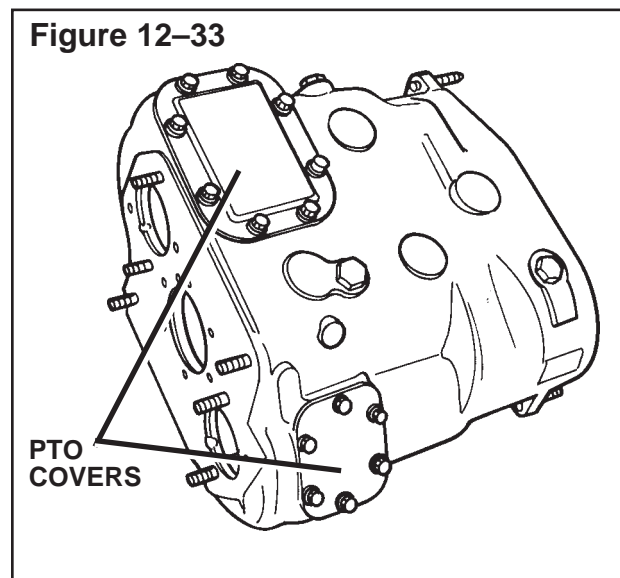

Installing the PTO Covers

1. Use a sealant dispenser and Loctite®, RTV Sealant™, #5699 (Meritor Part Number 2297-A-7021) or equivalent to put a sealant pattern for the PTO covers on the case. Put a gasket sealant on the case. See “Installing the Sealant” in Section 1, “General Information”.

See **Figure 12-34** for the pattern for the bottom cover. See **Figure 12-35** for the pattern for the side cover.

2. Install the 8-hole PTO cover on the bottom of the case. Install the mounting capscrews and washers. Tighten the capscrews to 35-45 lb-ft (47-61 N.m). **T**
3. Install the 6-hole PTO cover on the side of the case. Install the mounting capscrews and washers. Tighten the capscrews to 35-45 lb-ft (47-61 N.m). **T**

Installing the Magnets

1. Use a weak alkaline solution or a commercial cleaning solvent to remove all oil and dirt from the case. Dry the case before installing the magnets.
2. Remove all dirt and metal particles from the magnets. Put an adhesive, such as Loctite®, RTV Sealant™, #5699 (Meritor Part Number 2297-A-7021) or equivalent on the bottom of the magnets. Install the four magnets in the bottom of the case. **Figure 12-36**.
3. Install the main countershafts, the input shaft and the mainshaft as described in this section.

Figure 12-34

PTO COVERS-TO-TRANSMISSION CASE GASKET PATTERN

• PUT THE PATTERN ON THE TRANSMISSION CASE

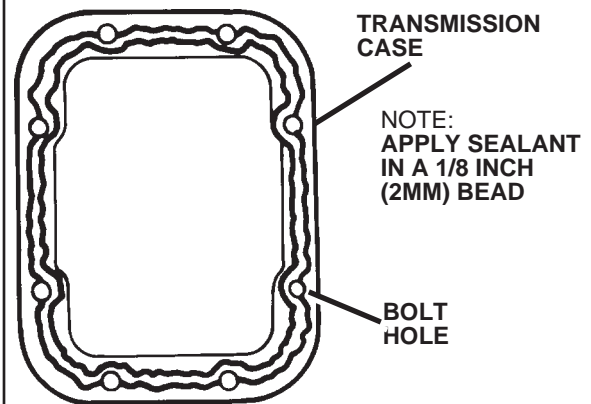

Figure 12-35

PTO COVERS-TO-TRANSMISSION CASE GASKET PATTERN

• PUT THE PATTERN ON THE TRANSMISSION CASE

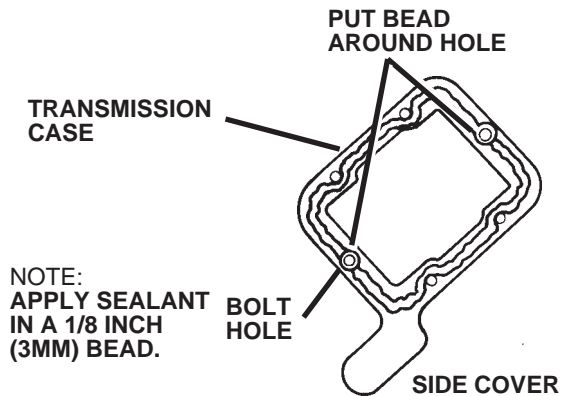
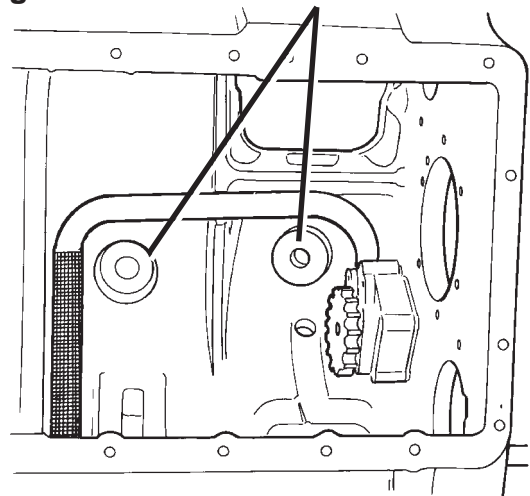

Figure 12-36

MAGNETS



Section 12

Overhauling the Main Case

Installing the Oil Pump

See Figure 12-37.

1. Lubricate all parts with new oil that is used in the transmission.
2. Install the pump in the case. Install the capscrews and the washers. Tighten the capscrews to 7-10 lb-ft (10-13 N.m). **T**
3. Connect the pick-up tube bracket to the case. Install and tighten the cap-screw.
4. Install the main countershafts, the input shaft and the mainshaft as described in this section.

Figure 12-37

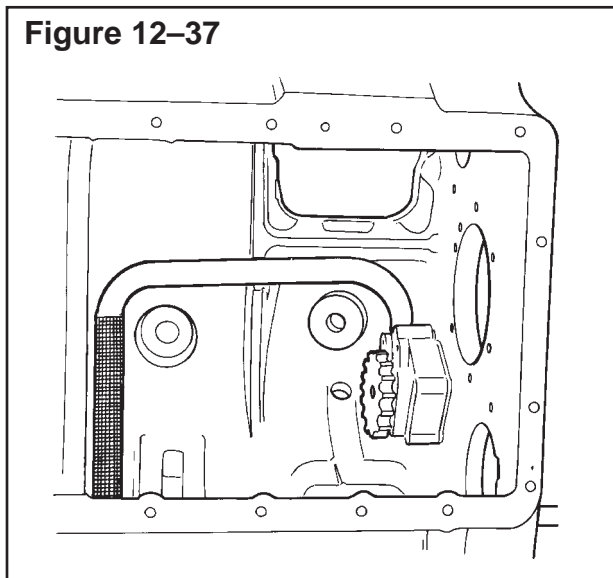

Installing the Reverse Idler Gear Assemblies

1. Lubricate all parts with new oil that is used in the transmission.
2. Install the needle bearing assembly inside the lower reverse idler gear. **Figure 12-38.**
3. Install the inner race inside the needle bearing assembly. **Figure 12-38.**
4. Install a spacer washer on each side of the reverse idler gear. **Figure 12-38.**

Figure 12-38

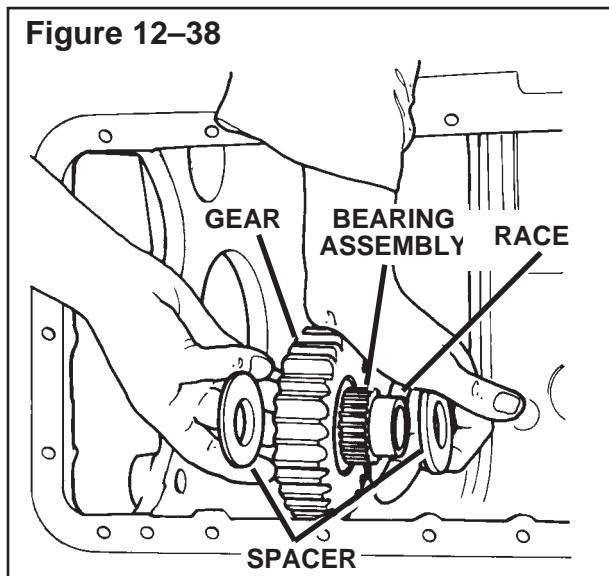

5. Put the lower reverse idler gear in position in the bottom of the case.
6. From the auxiliary cover side of the transmission case, install the shaft through the reverse idler gear assembly.
7. Install the nut and the washer that fastens the lower reverse idler gear assembly in the case. Hold the end of the shaft with a screwdriver. Tighten the nut to 75-100 lb-ft (101-135 N.m).

Figure 12-39. **T**

Figure 12-39

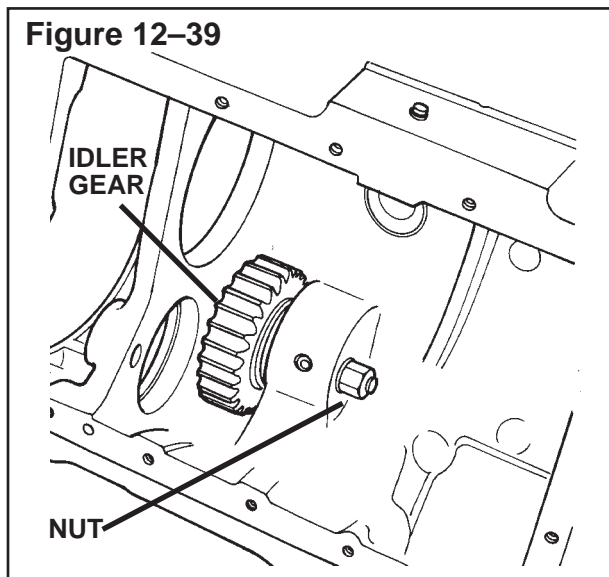

Section 12

Overhauling the Main Case

8. Install the countershafts, the input shaft and the mainshaft as described in this section. The procedure to install the upper reverse idler gear assembly is in "Installing the Mainshaft" in this section.

Installing the Input Shaft

1. Use paint to put a timing mark on one tooth of the main driven gear on the input shaft. Put another paint mark directly opposite (180°) the first mark. **Figure 12-40.**

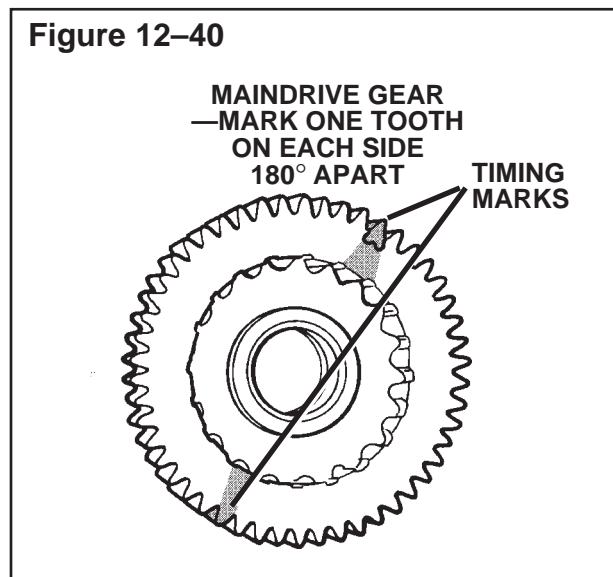

2. **On Design Level 1 Transmissions**, if required, disassemble the input shaft. See the following procedure.

Figure 12-41.

- a. Lubricate all the parts with new oil that is used in the transmission.
- b. If removed, install a new bushing in the end of the input shaft. Use a hammer and the correct driver tool to install the bushing.
- c. Install the snap ring in the groove inside the main drive gear.
- d. Align the splines of the input shaft with the splines inside the main drive gear. Install the main drive gear over the input shaft.

- e. Install the spacer on top of the gear.

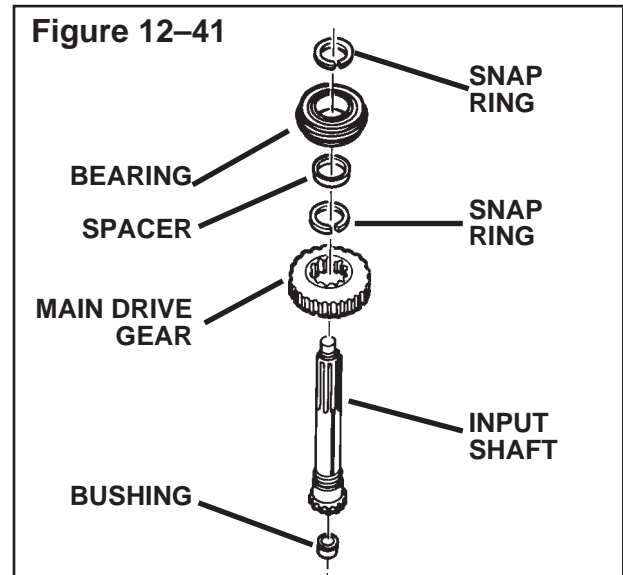

- f. Use a press and a sleeve to install the bearing on the input shaft. Support the bearing on the press so that the main drive gear is toward the top of the press. Press on the gear until the bearing touches the spacer. Make sure the bearing rotates after the shaft is installed.

Figure 12-42.

- g. Install the snap ring that fastens the bearing on the input shaft.

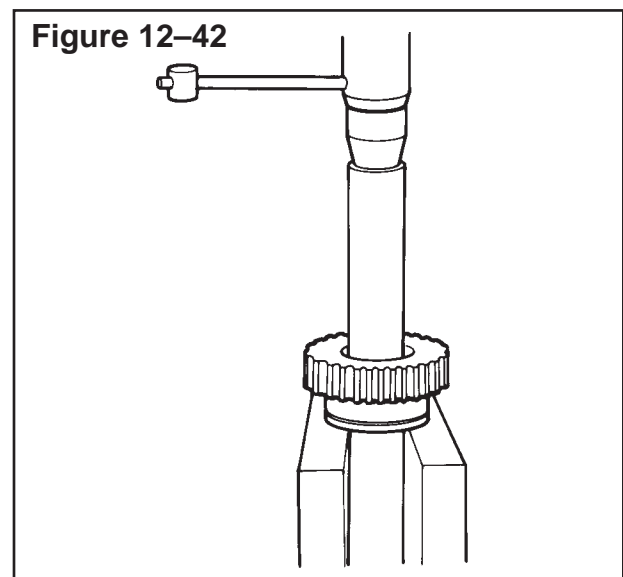

Section 12

Overhauling the Main Case

3. **On Design Level 1 Transmissions,** install the input shaft. See the following.
 - a. If installed, remove the outer snap ring from the input bearing.
 - b. Install the input shaft assembly through the inside of the case.
 - c. Use a rubber mallet to tap the input shaft assembly in position. The input shaft assembly is correctly installed when there is a slight clearance between the main drive gear and the transmission case. **Figure 12-43.**

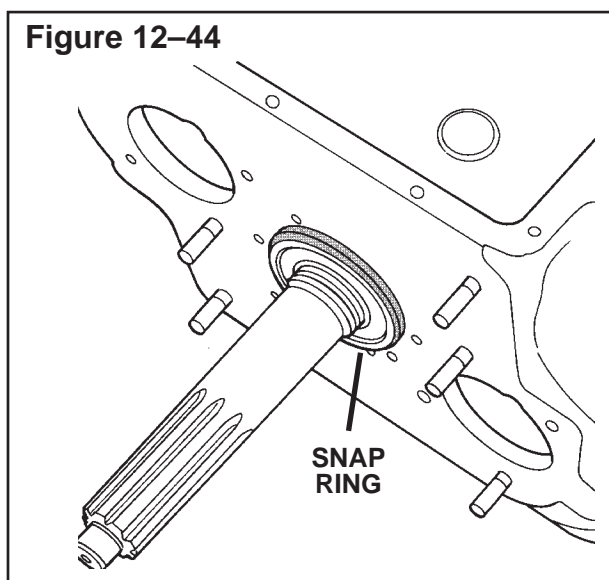
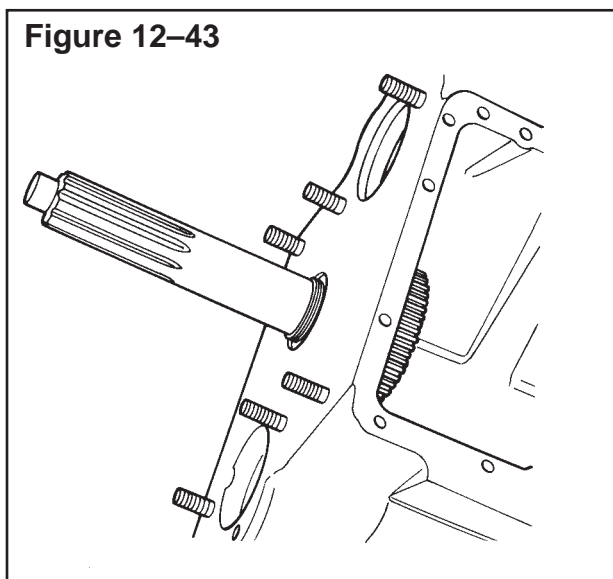

- d. Install the snap ring in the groove on the input shaft bearing. **Figure 12-44.**
4. **On Design Level 2 Transmissions,** install the input shaft. See the following procedure.
 - a. Lubricate all parts with new oil that is used in the transmission
 - b. If removed, install the snap ring inside the main drive gear.
 - c. Install the main drive gear in position in the case. **Figure 12-45.**

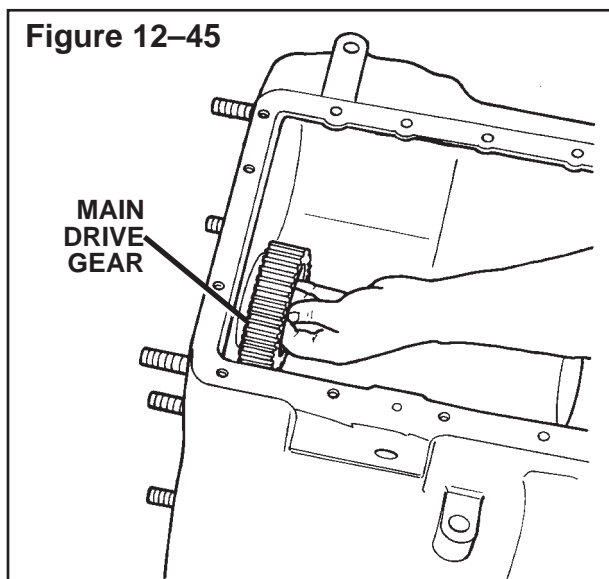

- d. If removed, install a new bushing in the end of the input shaft. Use a hammer and the correct driver to install the bushing.
 - e. Install the input shaft through the main drive gear. The shaft is correctly installed when the groove for the snap ring on the shaft is towards the outside the case. **Figure 12-46.**

Section 12 Overhauling the Main Case

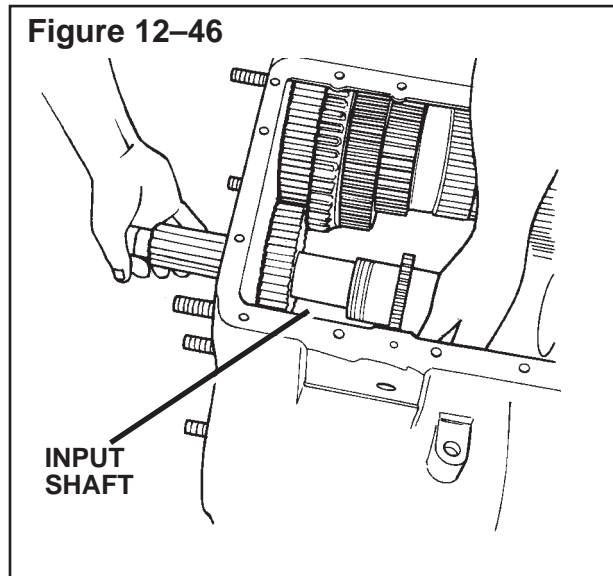

- f. Install the spacer on the input shaft. **Figure 12-47.**

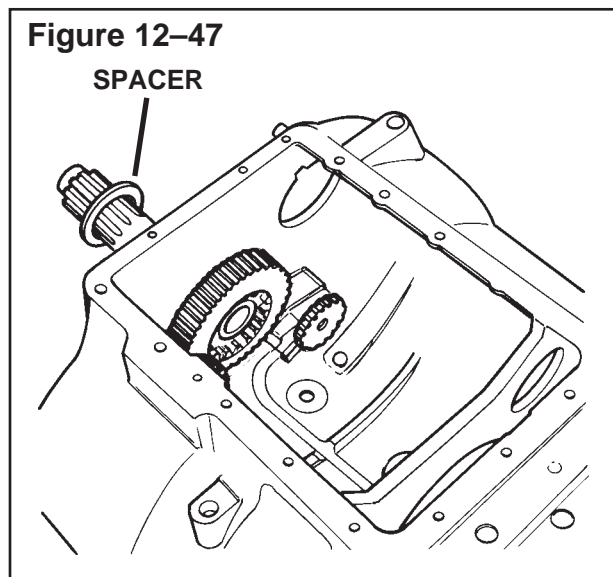

- g. If removed, install the outer snap ring on the bearing.
- h. Install the bearing over the shaft and in the case. **Figure 12-48.**

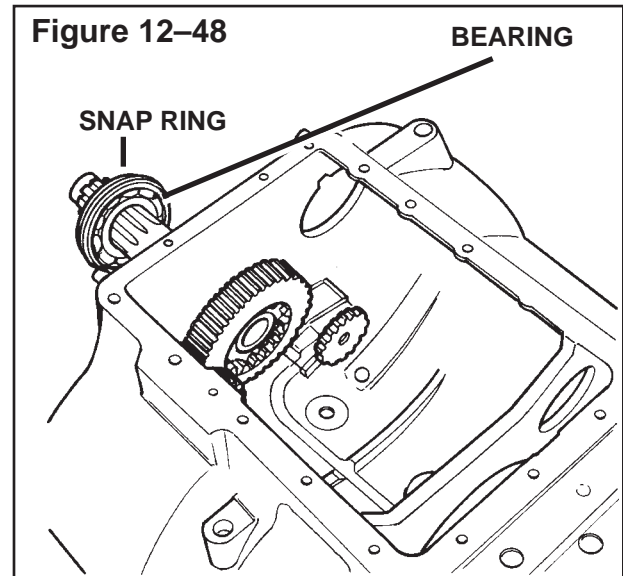

CAUTION

Put the tube on the inner race of the bearing. If tools are used in any other place on the bearing, the bearing will be damaged.

- i. Put the bearing over the input shaft and in the case. Use a rubber or plastic mallet and G&W Tool, G-35, Input Shaft Bearing Driver to install the bearing on the input shaft. The bearing is correctly installed when the snap ring touches the case. **Figure 12-49.**

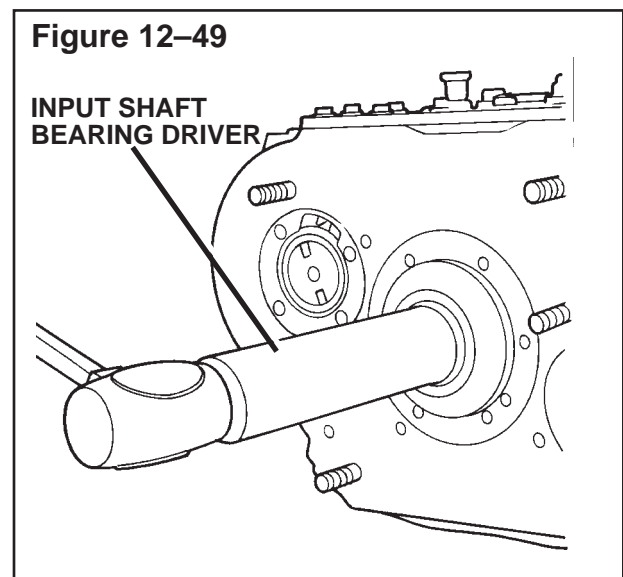

Section 12

Overhauling the Main Case

- j. Install the snap ring in the groove on the input shaft bearing.
Figure 12-50.

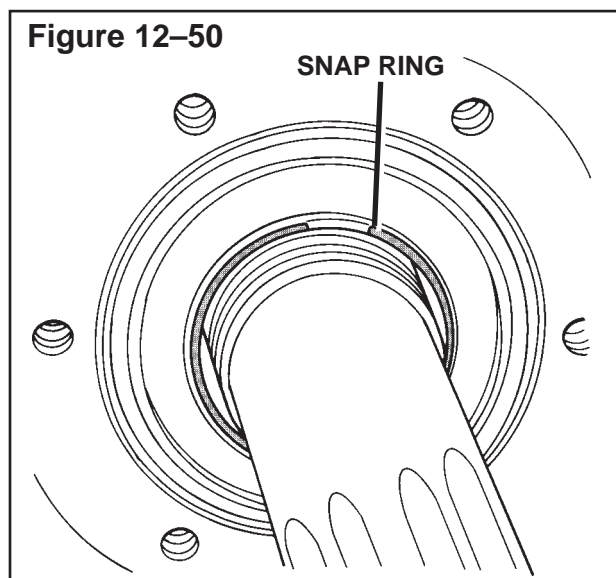

5. Use a sealant dispenser and Loctite® RTV Sealant™, #5699 (Meritor Part Number 2297-A-7021), to put a new sealant pattern on the case for the retainer in the pattern shown in **Figure 12-51**. See “Gasket Sealant” in Section 1.
6. Put the input bearing retainer on the case. Install the mounting capscrews and washers. Tighten the capscrews to 25-35 lb-ft (34-47 N.m).
Figure 12-52.



Figure 12-51

INPUT BEARING RETAINER-TO-TRANSMISSION CASE GASKET PATTERN

- PUT THE PATTERN ON THE INPUT BEARING RETAINER

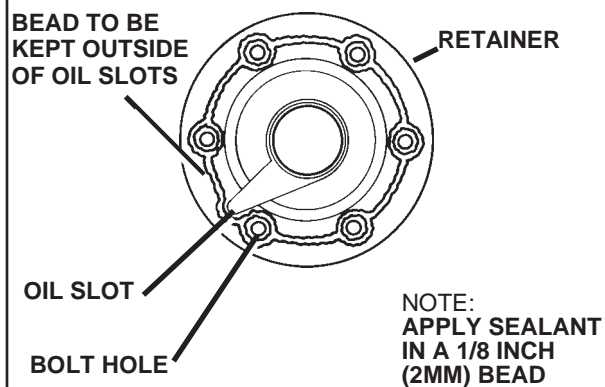
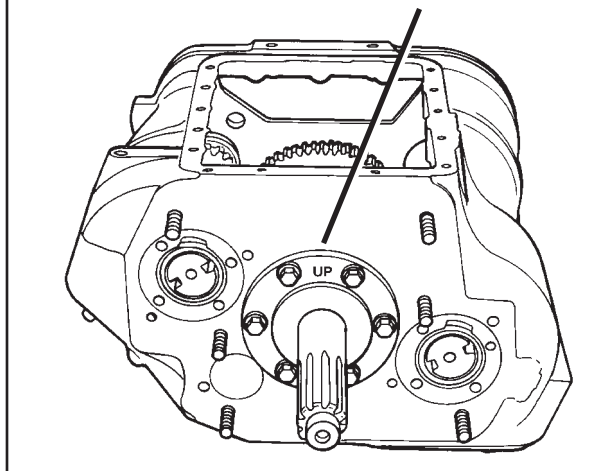

Figure 12-52

INPUT BEARING RETAINER



Installing the Main Countershafts

NOTE:

The bearing cup and the bearing cone must be replaced as an assembly. Do not replace the cup or the cone separately. Replace the cup and the cone in a matched set from the same manufacturer.

1. Lubricate all parts with new oil that is used in the transmission.
2. Use paint to put a timing mark on two teeth of each countershaft driven gear. Make sure the timing mark is aligned with the slot for the key and the "O" stamping on the countershaft. **Figure 12-53.**

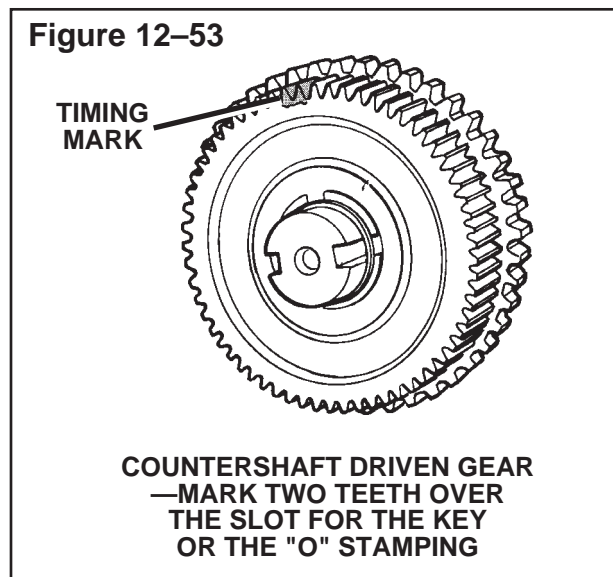

3. Use paint to put a timing mark on one tooth of the main drive gear on the input shaft. Put another paint mark directly opposite (180°) the first mark. **Figure 12-54.**

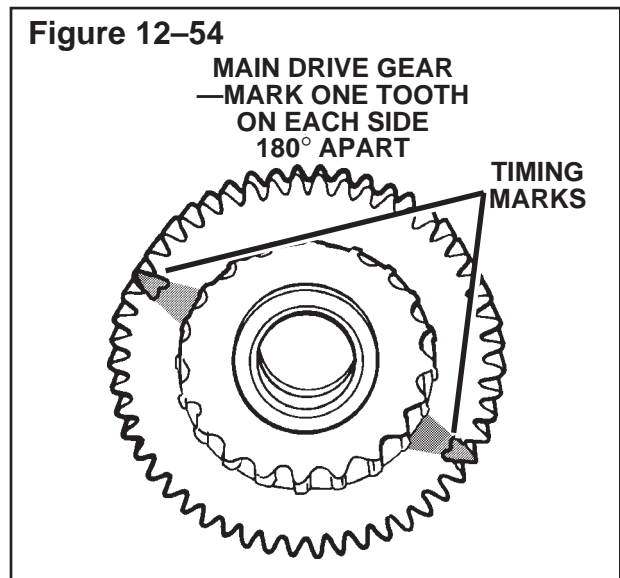

4. Install the lower countershaft so that the large gears are toward the front of the case. Move the countershaft toward the side of the case. **Figure 12-55.**

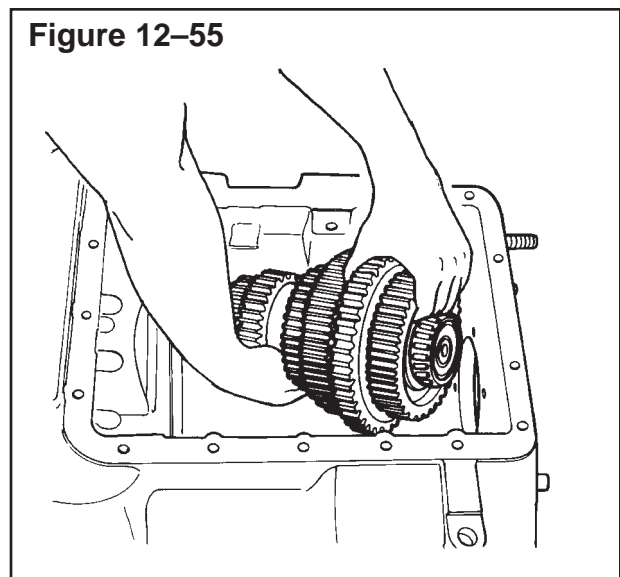

5. Install the upper countershaft assembly in the case. The large gears must be toward the front of the case. Move the countershaft toward the side of the case. **Figure 12-56.**

Section 12

Overhauling the Main Case

Install a long capscrew or T-Handle Tool, 3256-Y-1013, in the hole in the front of the upper countershaft. The tool or the capscrew makes the countershaft easier to move.

Figure 12-56

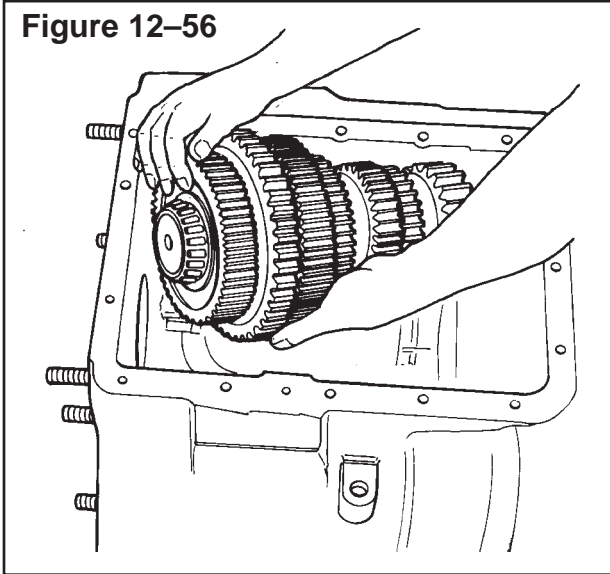

6. Rotate the input shaft and move the lower countershaft assembly so that the timing marks are aligned.

Figure 12-57.

7. Install the mainshaft as described in this section.

Figure 12-57

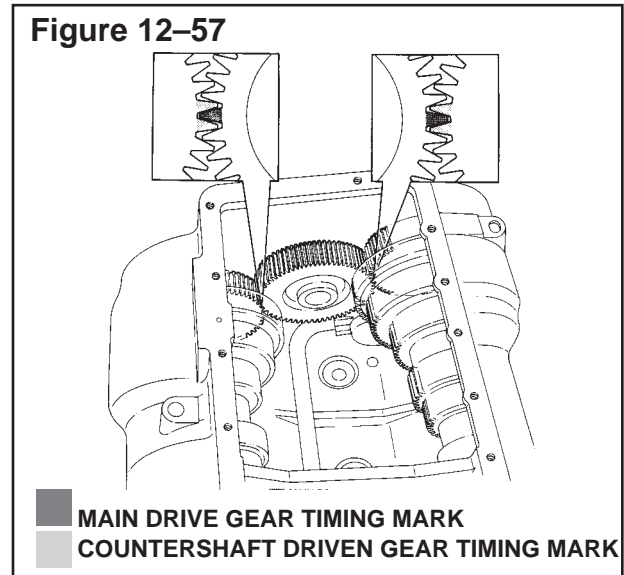

Installing the Mainshaft

⚠ WARNING

Wear safe eye protection and make sure the tools are in safe condition. If the tools are worn or damaged (“mushroomed”), pieces can break and cause serious personal injury.

To install the mainshaft, the input shaft and the main countershafts must be installed in the case.

NOTE:

Apply Loctite #242 (Meritor Part Number 2297-V-5430) or equivalent on the threads of the fasteners.

1. Lubricate all parts with new oil that is used in the transmission.

NOTE:

The rear bearing cone must be installed on the upper countershaft.

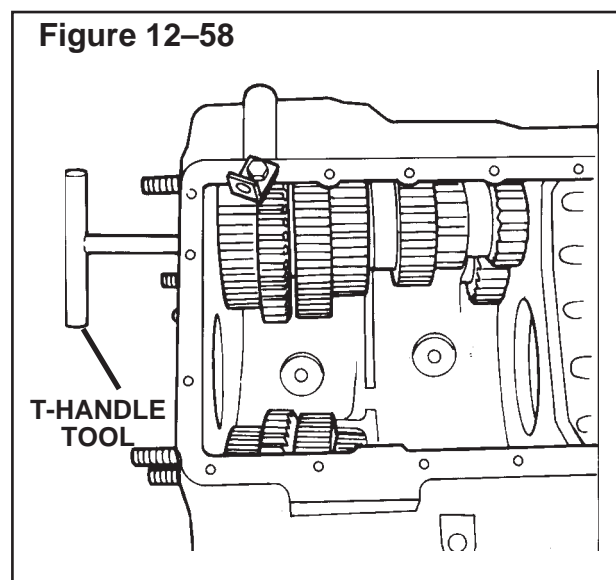

2. Move the upper countershaft toward the side of the case. **Figure 12-58.**

Install a long capscrew or T-Handle Tool, 3256-Y-1013, in the hole in the

Figure 12-59

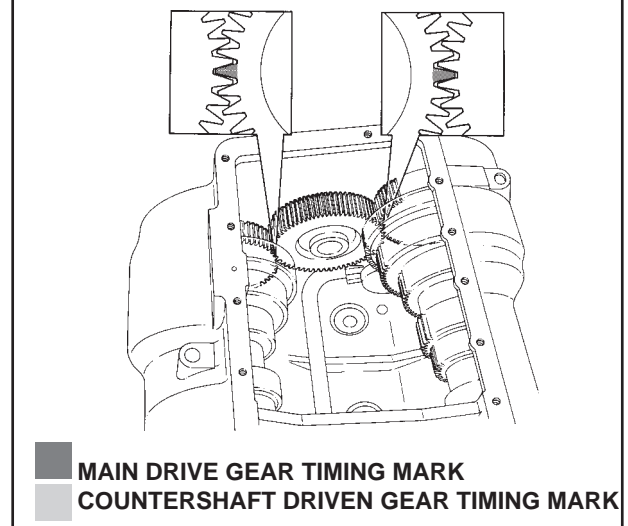

front of the upper countershaft. The tool or the capscrew makes the countershaft easier to move.

3. Rotate the input shaft and move the lower countershaft assembly so that the timing marks are aligned. **Figure 12-59.**
4. Remove the snap ring to remove the auxiliary drive gear assembly from the mainshaft.

Section 12

Overhauling the Main Case

- Remove the snap ring that fastens the reverse gear to the mainshaft. Slide the reverse gear forward until the gear touches the low gear. **Figure 12-60.**
- Install the sliding collar on the front of the mainshaft. **Figure 12-60.**

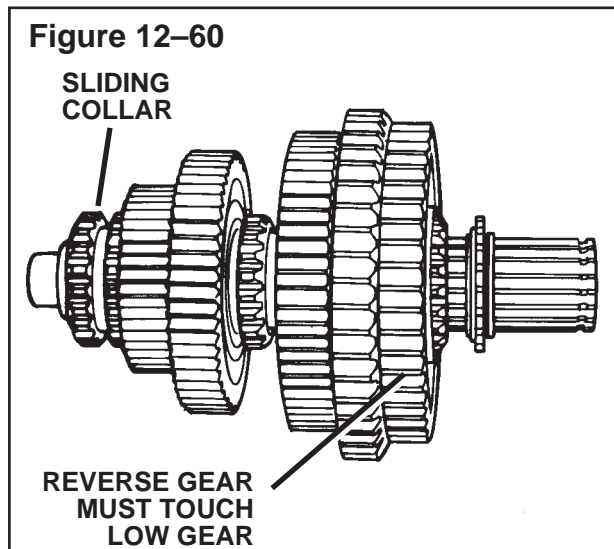

- Put lifting hooks or a rope under the mainshaft assembly. Install the mainshaft assembly in the case. Make sure the front of the mainshaft is installed in the bushing in the input shaft. Temporarily install the auxiliary drive gear to support the rear of the mainshaft. Remove the lifting hooks or rope. **Figure 12-61.**

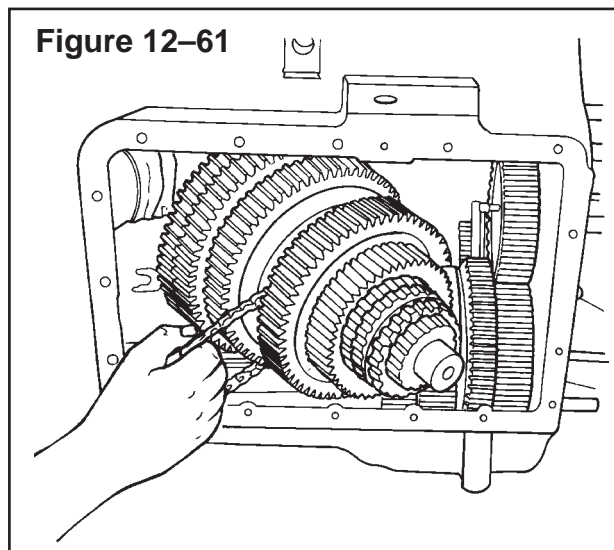

CAUTION

The mainshaft must be supported when the countershaft is serviced. If not supported, the timing marks fall out of alignment. The weight of the mainshaft will also damage the thrust washers between the gears.

- Install the auxiliary drive gear and bearing assembly so that the mainshaft is supported in the case.
- Align the timing marks on the main drive gear of the input shaft with the timing marks on the upper countershaft. Use the T-Handle Tool or the long capscrew to move the countershafts. **Figure 12-62.**

Remove the T-Handle Tool or long capscrews from the countershafts.

NOTE:

The bearing cone must be installed on the rear of the countershaft.

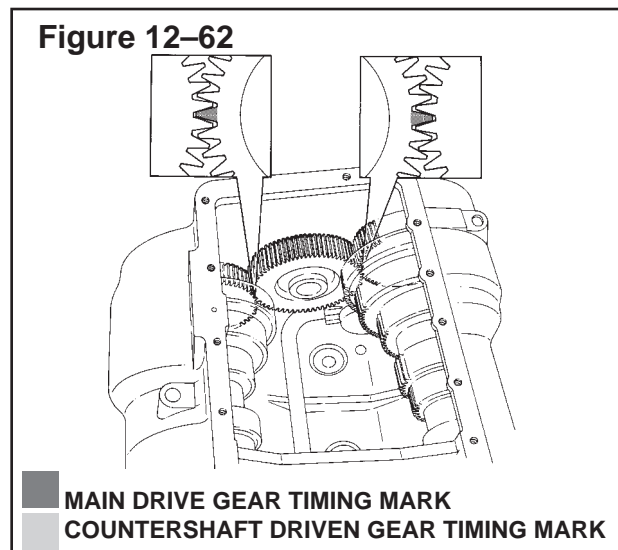

Section 12 Overhauling the Main Case

10. On Design Level 1 transmissions, install the upper rear bearing cup and the upper front bearing cup and cone on the countershaft. See the following procedure.
 - a. Put the cup in the bore for the upper rear countershaft. Use a plastic hammer to install the cup in the bore.
 - b. Use a hammer and a bearing driver tool to install the upper rear countershaft cup. The cup is correctly installed when the cup is past the snap ring groove. **Figure 12-63.**

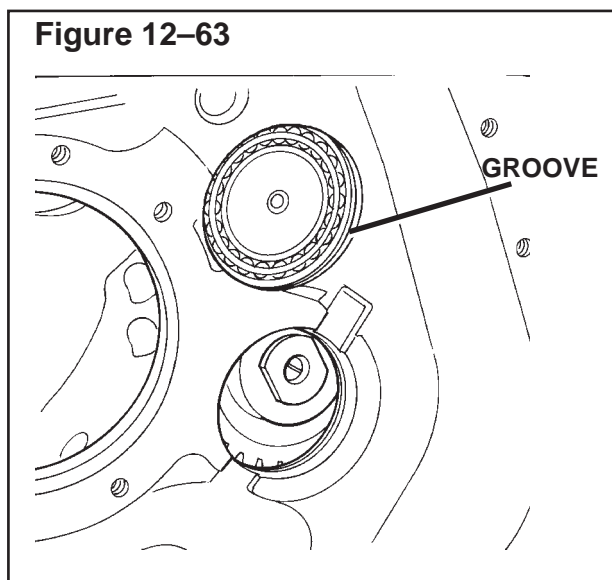

CAUTION

Use hand tools to rotate the forcing screw of the countershaft bearing pusher tool. If power tools are used, the tool will be damaged.

- c. Install Countershaft Bearing Pusher Tool, Meritor Part Number 3256-D-1044 or G&W Tool Number G-28 or equivalent, on the front of the countershaft. Rotate the forcing screw until the rear countershaft bearing cup is against the snap ring. **Figure 12-64.**

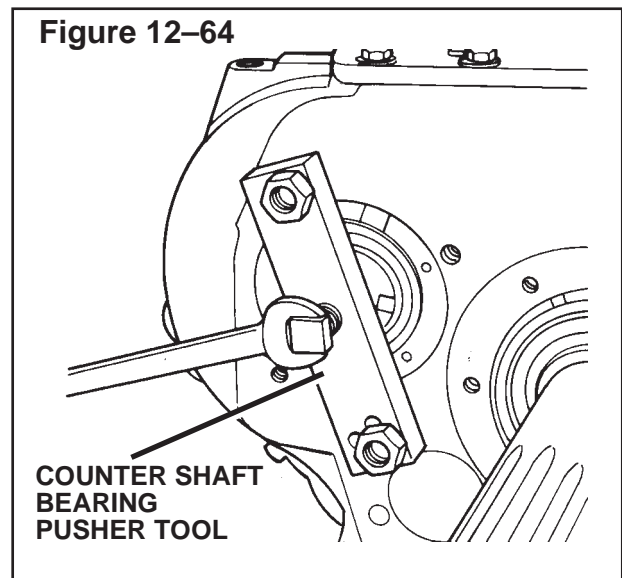

- d. Use a hammer and a bearing driver tool to install the upper front countershaft cone. The cone is correctly installed when the cone touches the countershaft. **Figure 12-65.**

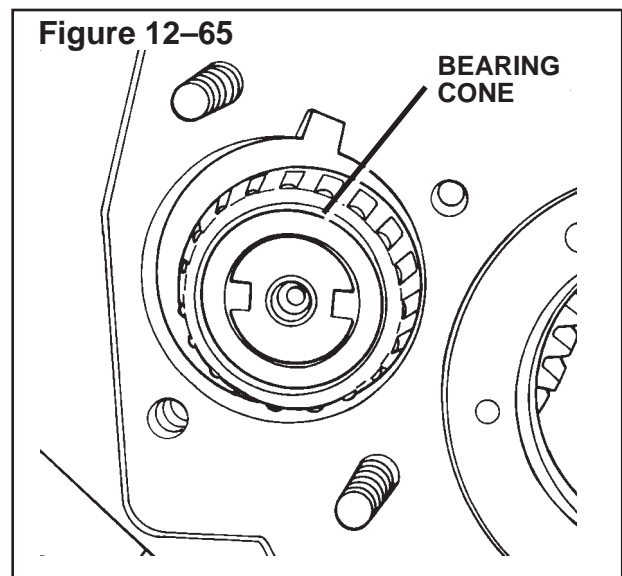

Section 12

Overhauling the Main Case

WARNING

Wear safe eye protection and make sure the tools are in safe condition. If the tools are worn or damaged (“mush-roomed”), pieces can break and cause serious personal injury.

- e. Use a hammer and a bearing driver tool to install the upper front countershaft cup. The cup is correctly installed when the cup is past the snap ring groove. **Figure 12-66.**

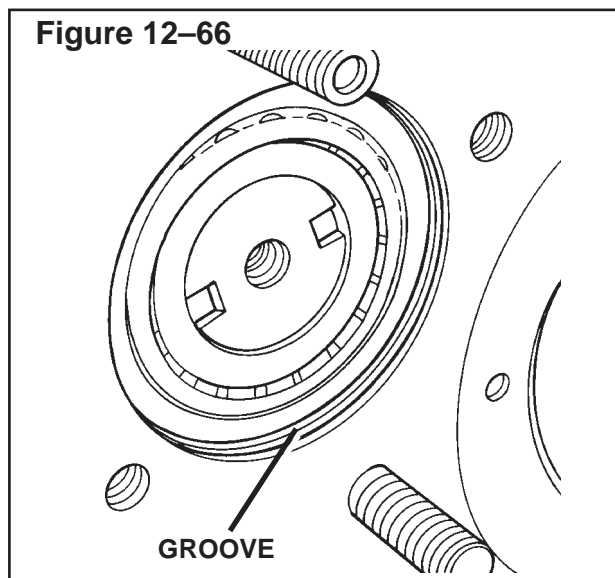

- f. Install the thinnest snap ring (0.068 inch or 1.73 mm), Meritor part number 1229-C-4215 in the bore for the front countershaft. The snap ring is used as a gauge. **Figure 12-67.**
- g. Install T-Handle Tool, Meritor part number, 3256-Y-1013, or a long capscrew in the front of the countershaft. **Figure 12-68.**
- h. Pull the countershaft and front cone assembly into the cup until the front cup is against the snap ring. **Figure 12-68.**
- i. Remove the T-Handle Tool or the long capscrew.

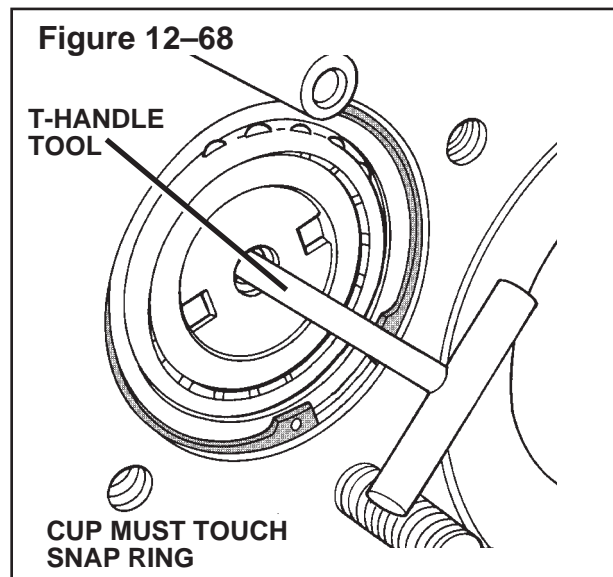
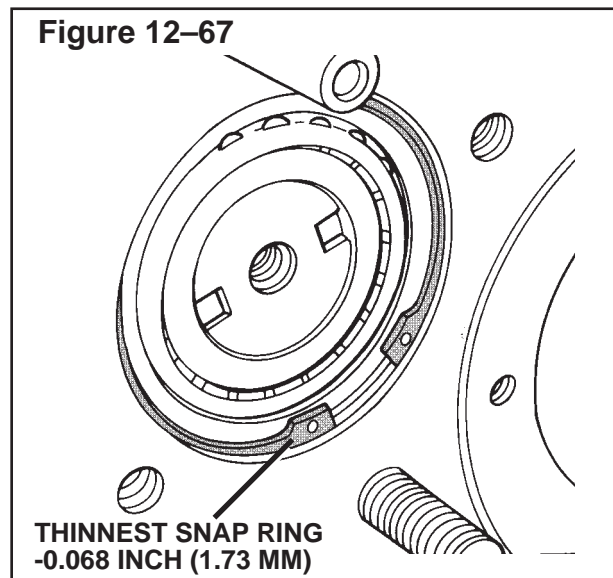

NOTE:

The bearing cone must be installed on the rear of the countershaft.

11. On Design Level 2 transmissions, install the upper rear bearing cup and the upper front bearing cup and cone on the countershaft. See the following procedure.
 - a. Put the cup in the bore for the upper rear countershaft. Use a plastic hammer to install the cup in the bore.

Section 12

Overhauling the Main Case

WARNING

Wear safe eye protection and make sure the tools are in safe condition. If the tools are worn or damaged (“mush-roomed”), pieces can break and cause serious personal injury.

NOTE:

The Piloted Bearing Driver Tool must install the cup so that the cup extends at least 0.125 or 1/8 inch (3 mm) above the surface of the case. Make sure the Driver Tool does not touch any part of the bearing cone or the cone will be damaged.

- b. Use a hammer and a Piloted Bearing Driver to install the rear cup in the bore. The cup is correctly installed when the cup extends 0.125 or 1/8 inch (3 mm) above the surface of the case. **Figure 12–69.**

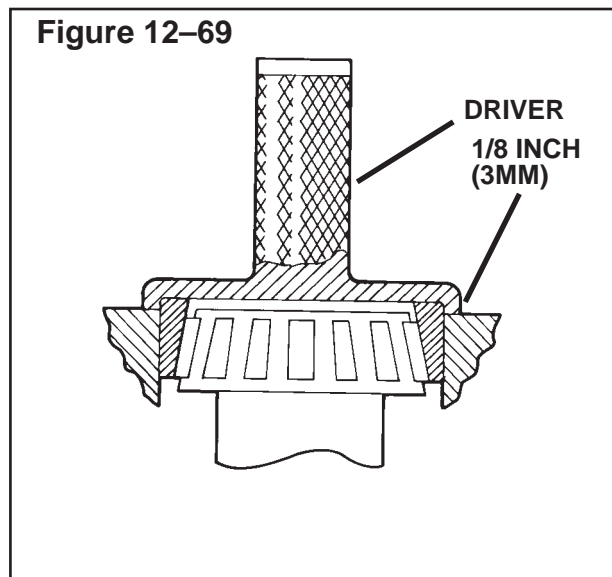

- c. Clean three capscrews that fasten the countershaft rear bearing retainer to the main case. Apply Loctite®#242 (Meritor Part Number 2297–V–5430) or equivalent to the threads of the capscrews.

CAUTION

Use a new hardened countershaft bearing retainer to install the rear countershaft cup. If a retainer that is not hardened is used, the transmissions will be damaged.

- d. Put a new hardened countershaft rear bearing retainer in position on the main case. Install the capscrews. Alternately and evenly tighten the capscrews to 35 lb-ft (47 N.m) until the retainer touches the main case. **Figure 12–70.** 

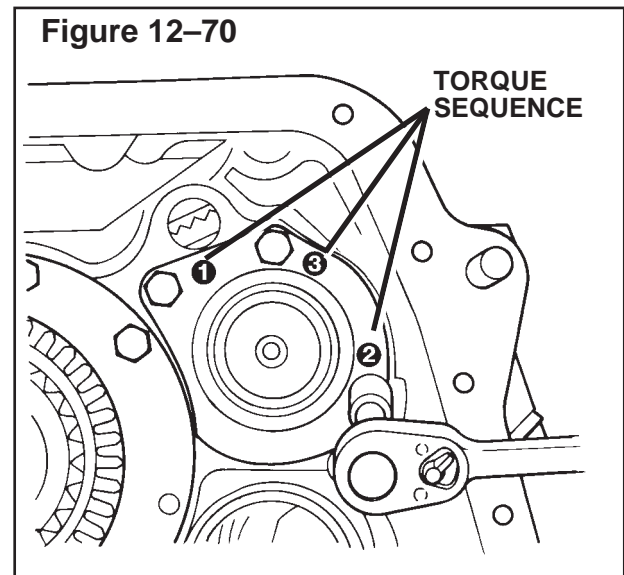

WARNING

Wear safe eye protection and make sure the tools are in safe condition. If the tools are worn or damaged (“mush-roomed”), pieces can break and cause serious personal injury.

- e. Use a hammer and a bearing driver tool to install the upper front countershaft cone. The cone is correctly installed when the bottom of the cone is against the countershaft. **Figure 12–71.**

Section 12

Overhauling the Main Case

Figure 12-71

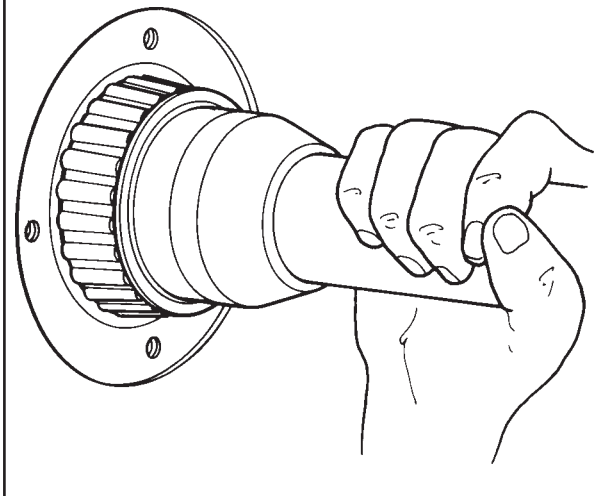

- f. Put the cup in the bore for the upper front countershaft. Use a plastic hammer to start installing the cup in the bore.

WARNING

Wear safe eye protection and make sure the tools are in safe condition. If the tools are worn or damaged (“mushroomed”), pieces can break and cause serious personal injury.

- g. Use a hammer and a bearing driver tool to install the upper front countershaft cup. The cup is correctly installed when the cup touches the bearing cone. **Figure 12-72.**

Figure 12-72

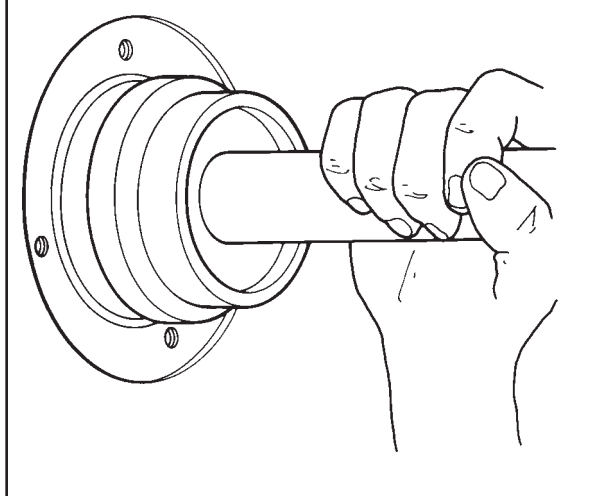

- h. Use a hammer and a Piloted Bearing Driver to install the front cup in the bore. The cup is correctly installed when the cup extends 0.125 inch (3 mm) above the surface of the case.

CAUTION

Make sure the retainer and the shims are correctly installed against the case. Make sure the retainer does not push the shims against the cup or the end play will not be correct.

- i. Install the shims in the bore for the upper front countershaft bearing. Replace any worn or damaged shims. Make sure the slot for the oil passage on the shims are aligned with the oil passage hole. Install the one of following shim selections. **Figure 12-73.**

Section 12

Overhauling the Main Case

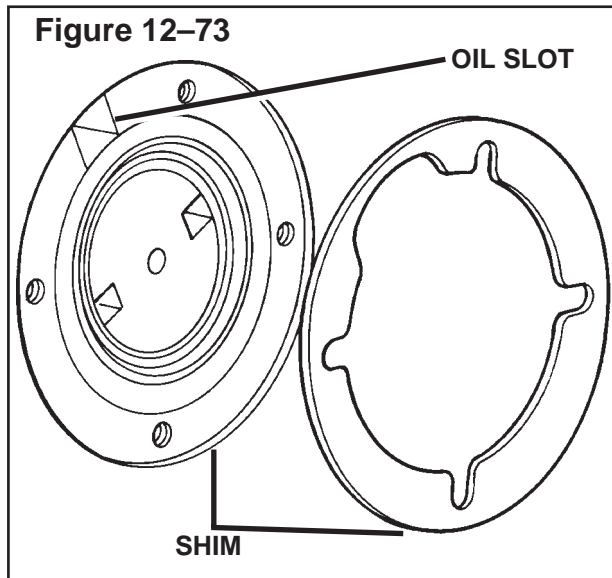

- The shims that were removed during disassembly.
- A 0.005 inch (0.127 mm) shim, Meritor part number, 2803-R-2826.
- A 0.0075 inch (0.190 mm) shim, Meritor part number, 2803-S-2827.

CAUTION

Make sure the retainer and the shims are correctly installed against the case. Make sure the retainer does not push the shims against the cup or the end play will not be correct.

- j. Install a new retainer for the upper and lower front countershaft bearings. Install the Allen-head cap-screws. Alternately and evenly tighten the capscrews to 120 lb-in (14 N.m). **Figure 12-74.** 

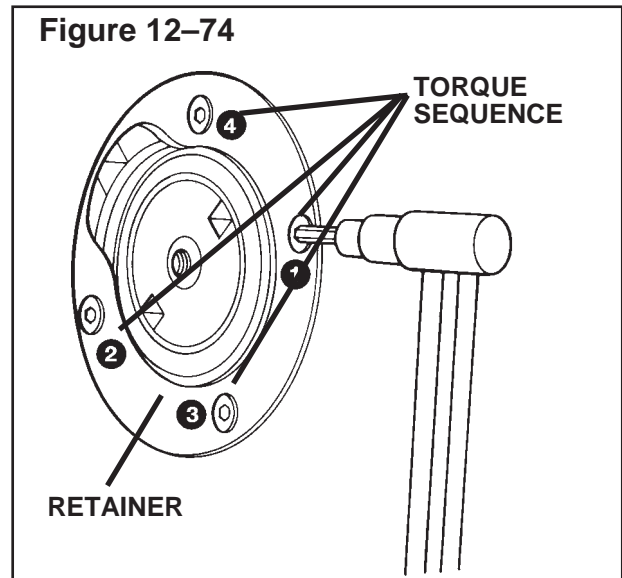

12. Check the end play on the upper and lower main countershafts as described in Section 17, "Main Countershaft End Play Adjustment". When the end play is between 0.002-0.006 inch (0.050-0.152 mm), go to step 13.
- 13 Install the upper reverse idler gear assembly in the top of the case. See the following procedure.
 - a. Install the needle bearing assembly inside the gear. **Figure 12-75.**

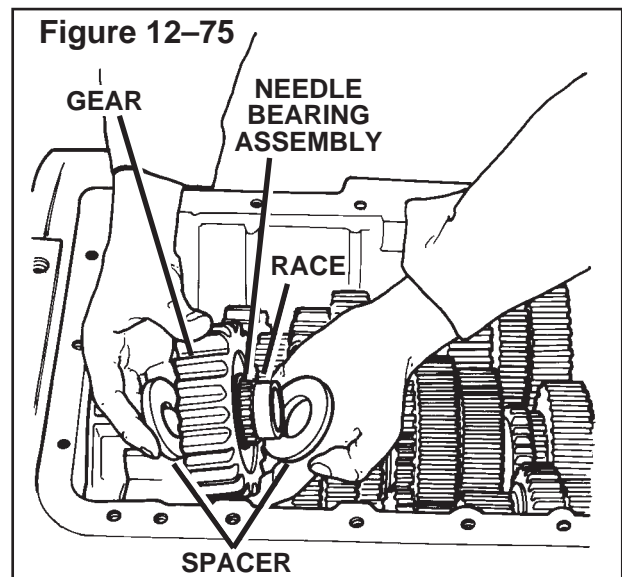

Section 12

Overhauling the Main Case

- b. Install the inner race inside the needle bearing assembly.
Figure 12-75.
- c. Install a spacer washer on each side of the reverse idler gear.
Figure 12-75.
- d. Put the reverse idler gear in position in the top of the case.
- e. From the auxiliary cover side of the transmission case, install the shaft through the reverse idler gear assembly.
- f. Install the nut and the washer on the upper reverse idler gear assembly. Hold the end of the shaft with a screwdriver. Tighten the nut to 75-100 lb-ft (100-135 N.m).
Figure 12-76.

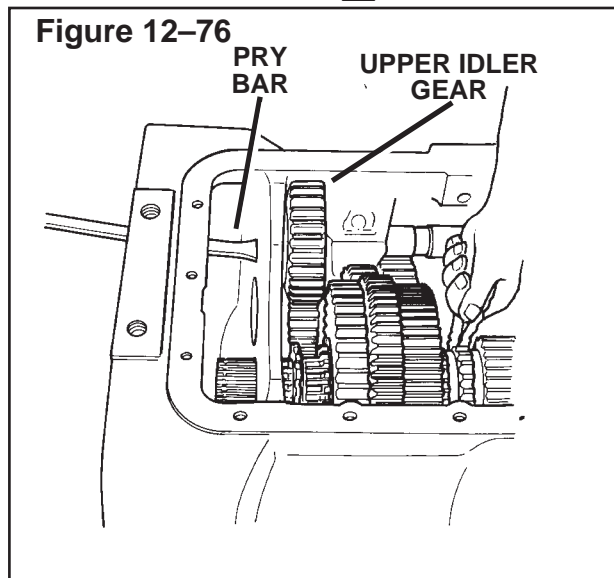

14. Move the reverse gear to the rear of the mainshaft. Remove the auxiliary drive gear. **Figure 12-77.**

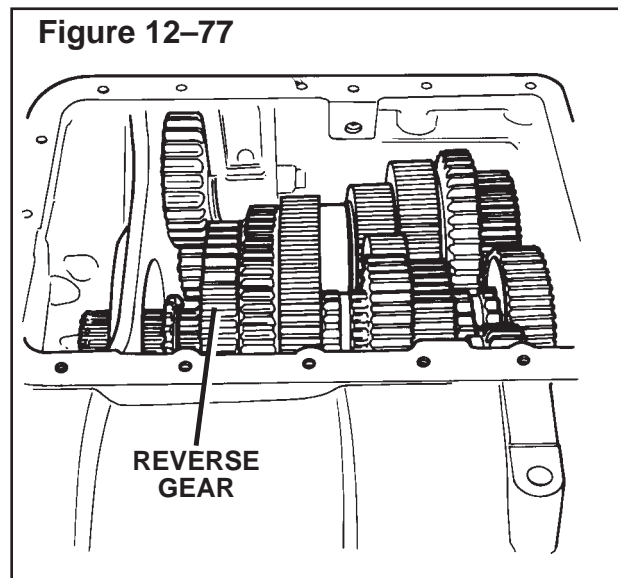

15. Install a new snap ring that fastens the reverse gear on the mainshaft. Make sure the snap ring is completely installed in the groove. **Figure 12-78.**

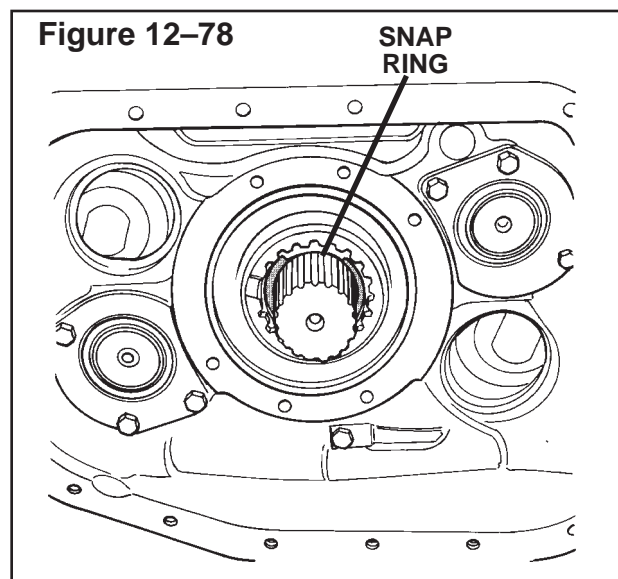

16. Install the thrust washer on the mainshaft. **Figure 12-79.**
17. Install the auxiliary drive gear assembly on the mainshaft and in the rear of the case. See the following.

Section 12 Overhauling the Main Case

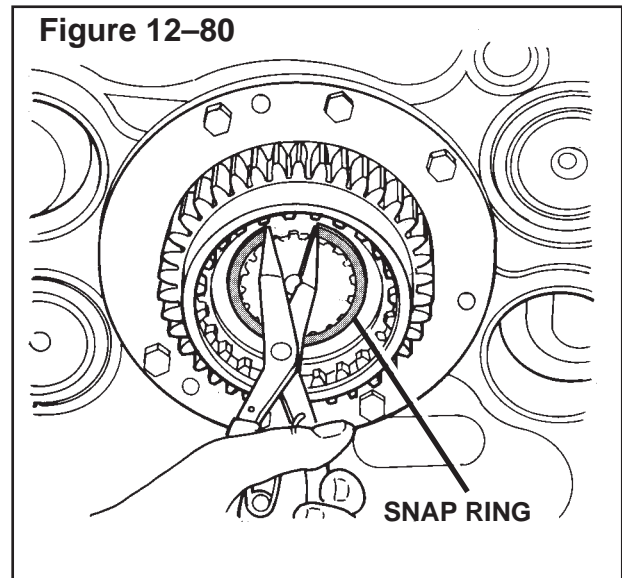
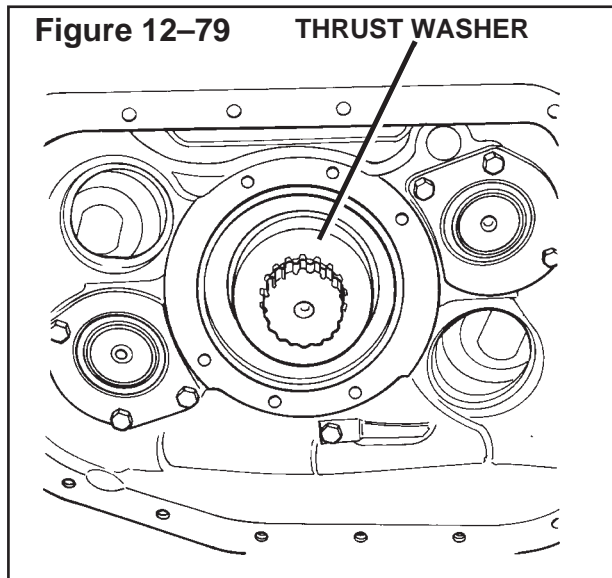

Round Retainer—Figure 12-80

- Install the retainer, the bearing and gear assembly on the mainshaft. Make sure the groove for the snap ring on the shaft is visible.
- Rotate the retainer so that the holes in the retainer are aligned with the bores in the case.
- Install and tighten the capscrews to 35-45 lb-ft (47-61 N.m) **T**

Two-Piece Retainer—Figure 12-81

- Install the bearing assembly in the case over the mainshaft.
 - Install the two-piece retainer on the case.
 - Install and tighten the capscrews to 35-45 lb-ft (47-61 N.m). **T**
 - Install the auxiliary drive gear on the mainshaft. Make sure the groove for the snap ring on the shaft is visible.
18. Install a new snap ring that fastens the auxiliary drive gear on the mainshaft. **Figure 12-80.**

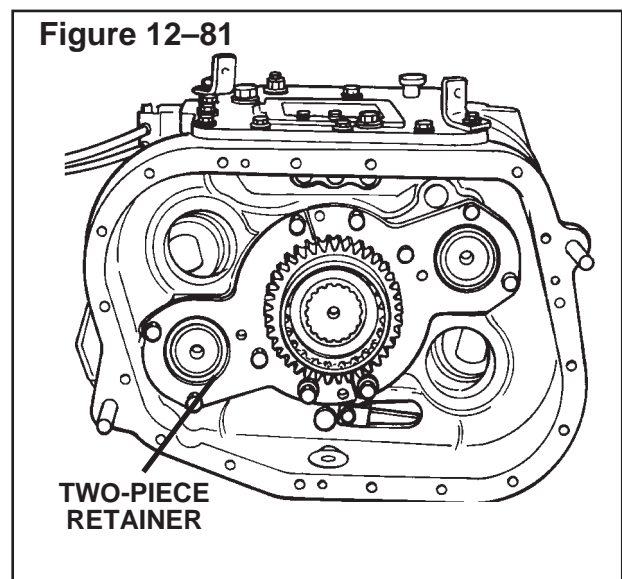

Section 13

Overhauling the Auxiliary Drive Gear



WARNING

To prevent serious eye injury, always wear safe eye protection when doing maintenance or service.

Disassembling the Auxiliary Drive Gear Assembly

1. Remove the auxiliary case. See Section 11, "Removing and Installing the Auxiliary Case".
2. Remove the capscrews that fasten the bearing retainer of the auxiliary drive gear to the transmission case. **Figure 13-1.**
3. Remove and discard the snap ring that fastens the auxiliary drive gear to the mainshaft. **Figure 13-1.**
4. If a two-piece retainer is used for the auxiliary drive gear, use pry bars to separate the auxiliary drive gear from the mainshaft. Remove the gear. Remove the two-piece retainer **Figure 13-2.**
5. If a round retainer is used for the auxiliary drive gear, clean the puller holes and install a 3/8"-16 x 1.00" capscrew in the three puller holes in the bearing retainer of the auxiliary drive gear. Evenly tighten the three capscrews to remove the auxiliary drive gear from the mainshaft.

If necessary, tap on the mainshaft with a rubber or plastic mallet to separate the gear from the mainshaft. Remove the round retainer. **Figure 13-3.**

Figure 13-1

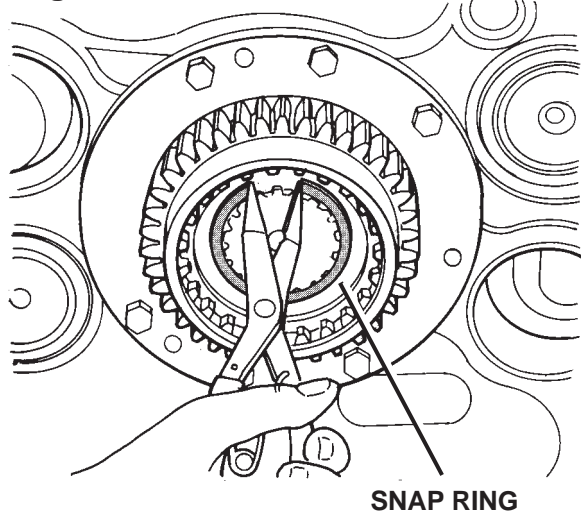

Figure 13-2

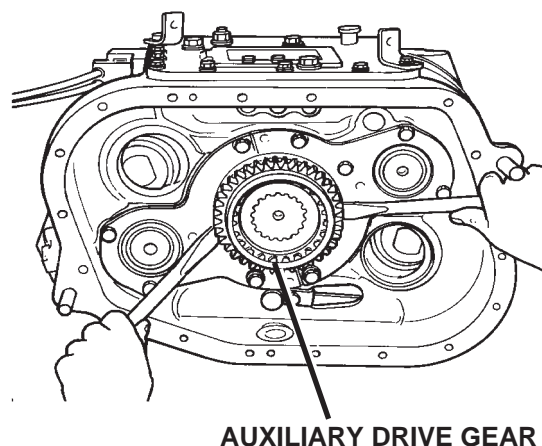
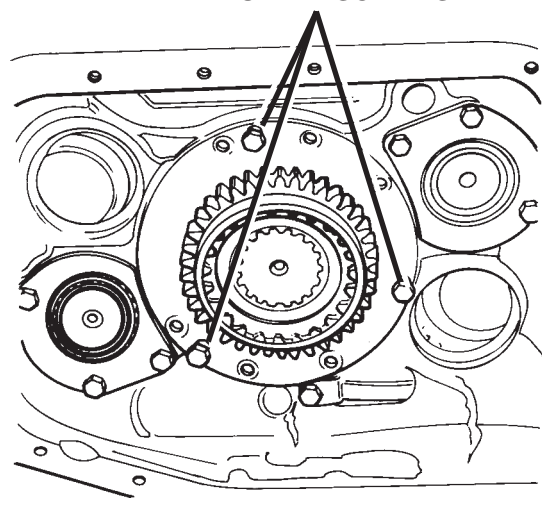

Figure 13-3

PULLER SCREWS



Section 13

Overhauling the Auxiliary Drive Gear

NOTE:

The ball bearing assembly for the auxiliary drive gear is sometimes come out when the auxiliary drive gear is removed. If necessary, pull on the assembly to separate the gear from the bearing.

5. If necessary, remove the ball bearing assembly from the main case. Put a pry bar under the snap ring on the ball bearing assembly for the auxiliary drive gear. Remove the bearing.

Figure 13-4.

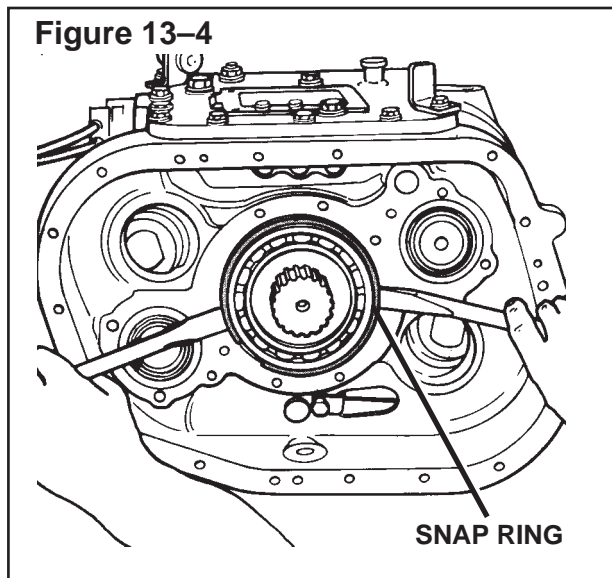

6. If worn or damaged, remove and replace the two O-rings from the bottom grooves of the auxiliary drive gear.
7. Inspect the teeth of the auxiliary drive gear. Replace the gear if the teeth are worn or damaged. Figure 13-5.

Figure 13-5

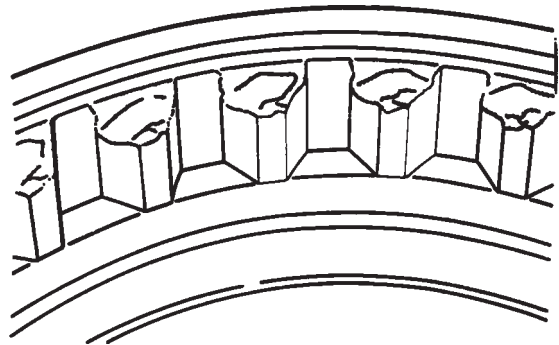

8. Inspect the synchronizer surface on the auxiliary drive gear. If the surface is discolored, worn or damaged replace the gear and the synchronizer. For synchronizer service procedures, see Section 16, "Overhauling the Auxiliary Case". Figure 13-6.
9. Inspect the ball bearing. Make sure the bearing rotates in the race and that the outer race is not worn or damaged. Replace worn or damaged bearings.

Figure 13-6

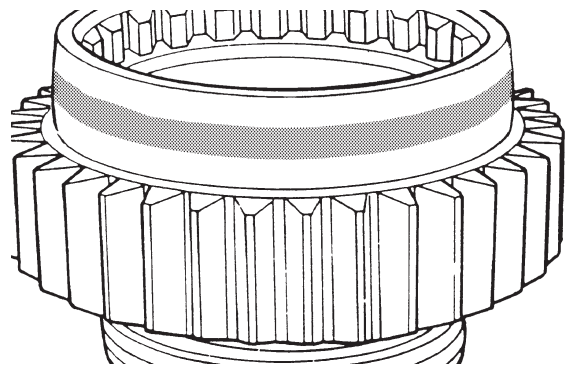

Section 13

Overhauling the Auxiliary Drive Gear

Assembling the Auxiliary Drive Gear Assembly

1. Lubricate all the parts with new oil that is used in the transmission.
2. If removed, install two, new O-rings in the bottom grooves of the auxiliary drive gear. Make sure the O-rings are lubricated with new oil that is used in the transmission. **Figure 13-7.**

Figure 13-7

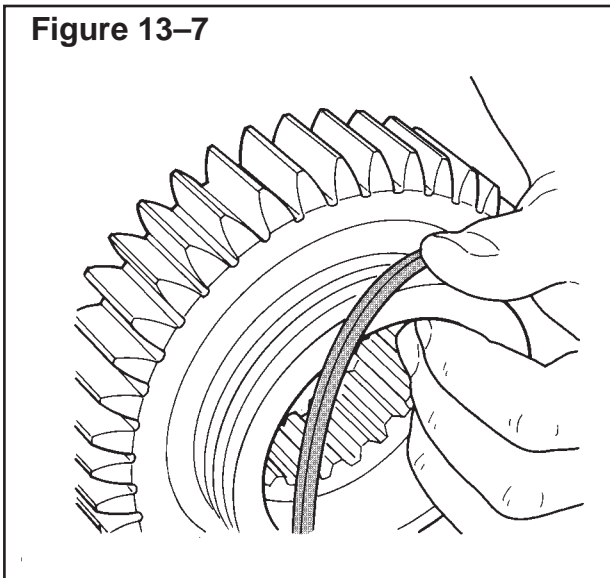

3. Install the auxiliary drive gear assembly on the mainshaft and in the rear of the case. See the following.

Round Retainer—Figure 13-8

- a. Install the retainer, the bearing and gear assembly on the mainshaft. Make sure the groove for the snap ring on the shaft is visible.
- b. Rotate the retainer so that the holes in the retainer are aligned with the bores in the case.
- c. Install and tighten the capscrews to 35-45 lb-ft (47-61 N.m) **T**

Two-Piece Retainer—Figure 13-9

- a. Install the bearing assembly in the case over the mainshaft.
- b. Install the two-piece retainer on the case.

Figure 13-8

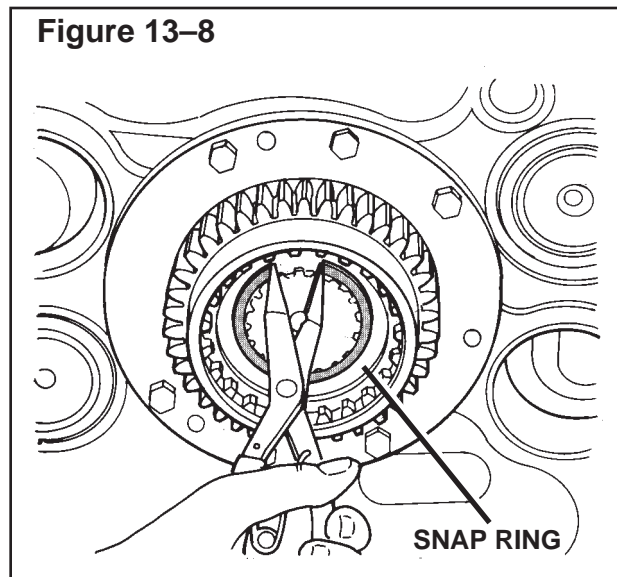
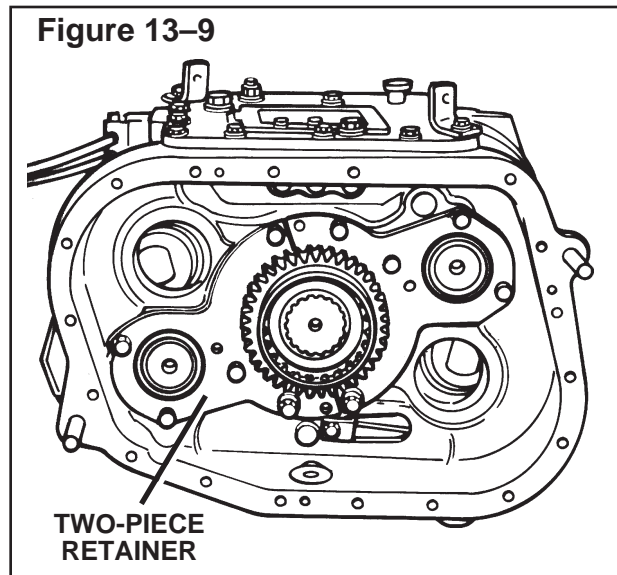

Figure 13-9



- c. Install and tighten the capscrews to 35-45 lb-ft (47-61 N.m). **T**
 - d. Install the auxiliary drive gear on the mainshaft. Make sure the groove for the snap ring on the shaft is visible.
4. Install a new snap ring that fastens the auxiliary drive gear on the mainshaft. **Figure 13-8.**
 5. Install the auxiliary case. See Section 11, "Removing and Installing the Auxiliary Case".

Disassembling the Mainshaft

See Figure 14-1.

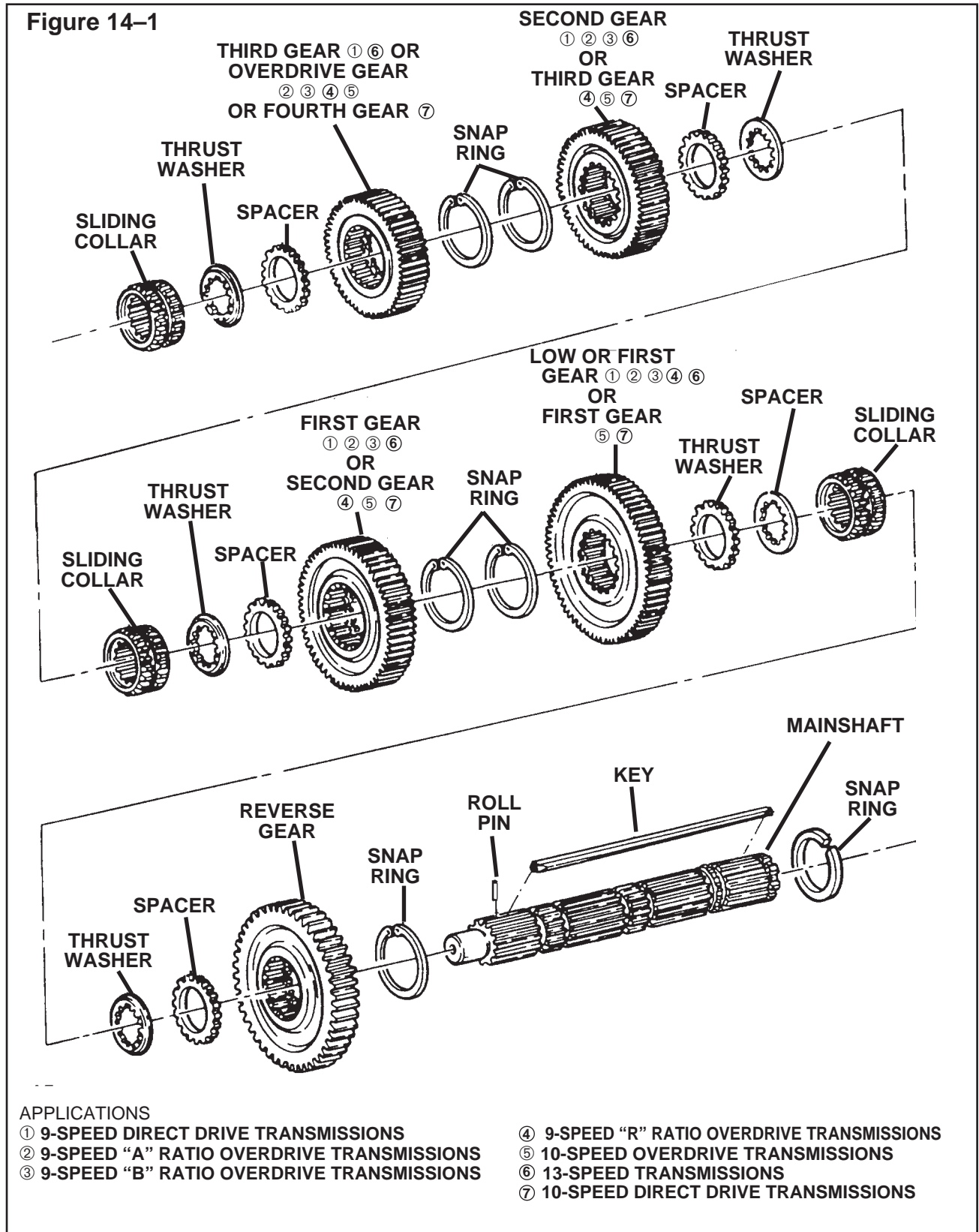

Section 14

Overhauling the Mainshaft



WARNING

To prevent serious eye injury, always wear safe eye protection when doing maintenance or service.

NOTE:

The thrust washer on the mainshaft, the snap ring in the reverse gear and the front sliding collar are removed when the mainshaft is removed from the transmission.

1. If installed, remove the 3rd-4th sliding collar from the mainshaft.
2. Put the mainshaft in a vise with brass jaws. Make sure the auxiliary drive gear end of the shaft is toward you.
3. Remove the following parts of the mainshaft in this order. Keep all parts together after disassembly.

NOTE:

See Figure 14–1 to identify the components of the mainshaft assembly for the transmission models.

- a. Remove the snap ring from the second groove from the top of the shaft.
- b. Use a small punch to push the key away from the roll pin at the bottom of the shaft.
- c. Remove the key from the top of the shaft.

- d. Remove the spacer and the thrust washer.
- e. Remove the reverse gear.
- f. Remove the clutch collar.
- g. Remove the thrust washer, the spacer and the low or the first gear.
- h. Remove the first or the second gear.
- i. Remove the spacer and the thrust washer.
- j. Remove the clutch collar .
- k. Remove the thrust washer, the spacer and the second or the third gear.
- m. Remove the overdrive or the third gear.
- n. Remove the spacer and the thrust washer.

NOTE:

Remove the roll pin, only if the pin is worn or damaged. The roll pin is difficult to remove.

4. If worn or damaged, remove and replace the roll pin.
5. If worn or damaged, remove and replace the snap rings from inside the gears. **Figure 14–2.**
6. Inspect all parts. See “Inspecting the Parts” in Section 1.

Section 14

Overhauling the Mainshaft

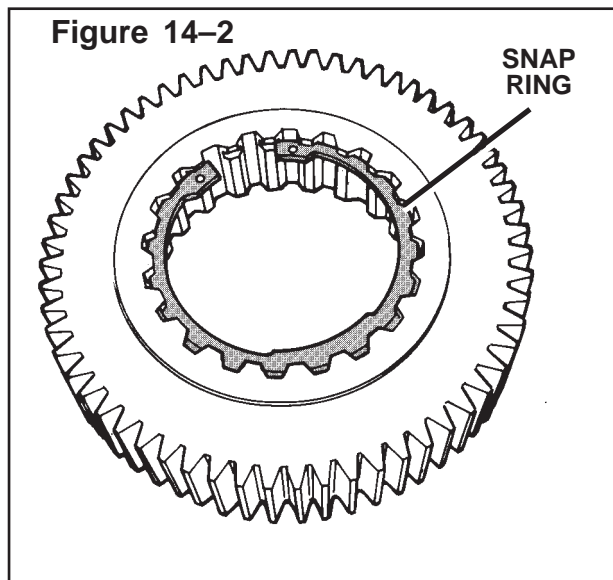

Assembling the Mainshaft

See Figure 14-1.

NOTE:

See Figure 14-1 to identify the components of the mainshaft assembly for the transmission models.

CAUTION

Use the correct snap ring in the gears or the transmissions will not operate correctly. Transmissions with serial numbers LB93021753 and below, use part number 1229-X-4418. Transmissions with serial numbers LB93021754 and above, use part number 1229-W-4625.

1. If removed, install the snap rings in the gears. **Figure 14-2**

WARNING

When using a hammer and a steel drift, wear safe eye protection and make sure the tools are in safe condition. Do not use tools that are worn or damaged ("mushroomed"). If the tools are not in safe condition, pieces can break and cause serious personal injury.

2. If removed, use a hammer and a steel drift to install a new roll pin.

Figure 14-3.

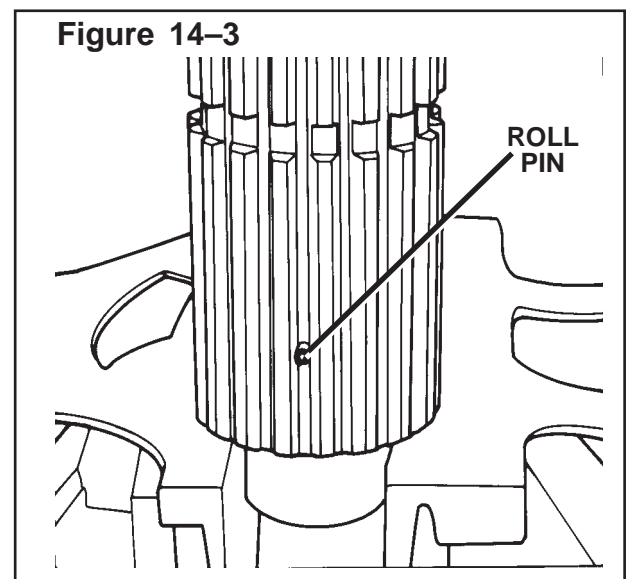

3. Lubricate all the parts of the mainshaft with the same oil used in the transmission.
4. Install the mainshaft in a vise with brass jaws. Make sure the slot for the key is toward you.

Section 14

Overhauling the Mainshaft

CAUTION

Use the correct selective washer. Do not mix washers or the transmission will not operate correctly.

5. Choose the correct selective thrust washer for the third or overdrive gear. See the following.
 - If the selective washers **are not replaced**, use the original washers.
 - If the selective washers **are replaced**, install the medium size of washer.

For transmissions with serial numbers LB93021753 and below, use a 0.220 inch (5.60 mm) washer.

For transmissions with serial numbers LB93021754 and above, use a 0.275 inch (7.00 mm) washer.

6. Install the selective thrust washer for the third or overdrive gear. See the following. **Figure 14-4.**
 - a. Install the washer on the shaft. Make sure the smooth side is towards you.
 - b. Slide the washer to the groove above the roll pin.
 - c. Move the washer so that the teeth of the washer are directly over the splines of the shaft. The washer must not slide down the shaft.

NOTE:

The key will be removed and installed during this procedure. Mark the groove where the roll pin is installed.

7. Install the key in the slot where the roll pin is installed. Make sure the key touches the roll pin. **Figure 14-5.**
8. Install the spacer on top of the washer. **Figure 14-5.**

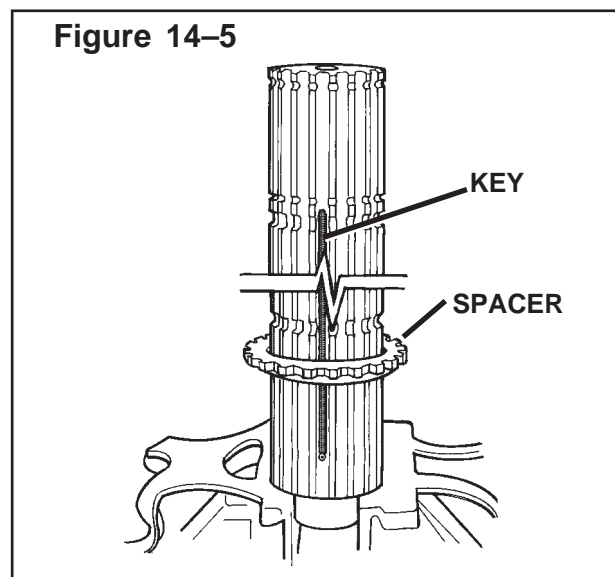
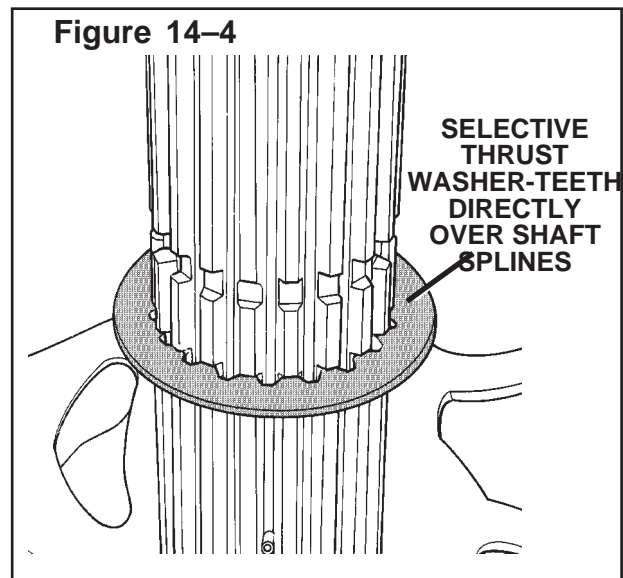

9. Install the third or the overdrive gear on the shaft. Make sure the splines in the gear engage the teeth on the spacer and the snap ring is against the spacer. **Figure 14-6.**

Section 14 Overhauling the Mainshaft

Figure 14-6

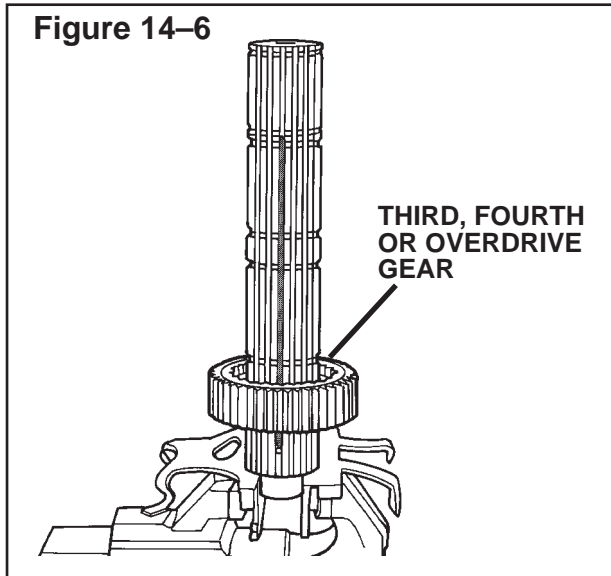

10. Install the second or the third gear. Make sure the snap ring is towards the third or overdrive gear. **Figure 14-7.**
11. Install a spacer. Make sure the teeth of the spacer engage the splines of the gear. **Figure 14-7.**

Figure 14-7

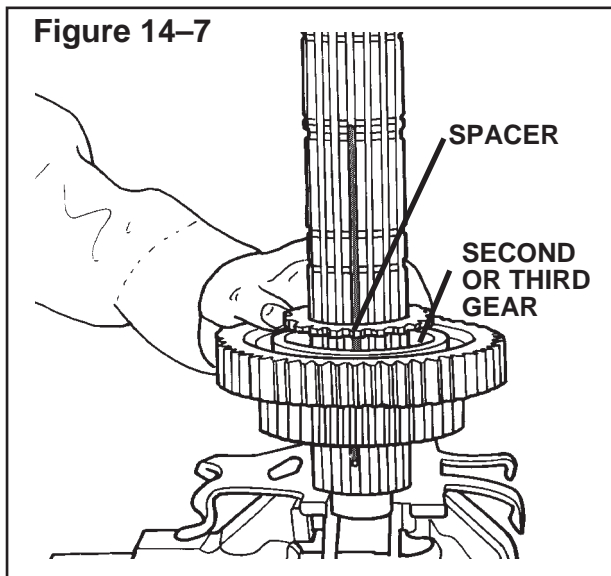

CAUTION

Make sure the selective washers do not move when the key is removed. If the washers move, the gears will fall and the assembly must be disassembled and assembled.

12. Remove the key.
13. Choose the correct selective thrust washer for the second or third gear. See the following.
 - If the selective washers **are not replaced**, use the original washers.
 - If the selective washers **are replaced**, install the thinnest size of washer.

For transmissions with serial numbers LB93021753 and below, use a 0.216 inch (5.50 mm) washer.

For transmissions with serial numbers LB93021754 and above, use a 0.272 inch (6.90 mm) washer.

14. Install the selective thrust washer for the second or third gear. See the following. **Figure 14-8.**

Figure 14-8

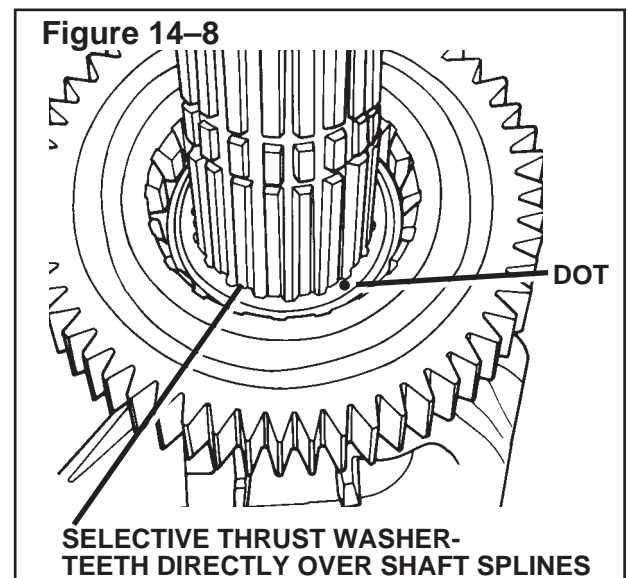

Section 14

Overhauling the Mainshaft

- a. Install the washer on the shaft. Make sure the chamfered side with the dot is towards you.
- b. Slide the washer to the second groove above the roll pin.
- c. Move the washer so that the teeth of the washer are directly over the splines of the shaft. The washer must not slide down the shaft.

If necessary, put a small screwdriver in the dot to move the washer. **Figure 14–8.**

15. Check the clearance between the third and the second gears or the overdrive and the third gears. See the following procedure.
 - a. Put two screwdrivers across from each other between the gears. **Figure 14–9.**
 - b. Lightly push on the screwdrivers to evenly spread the gears. Make sure the gears are parallel to each other. **Figure 14–9.**

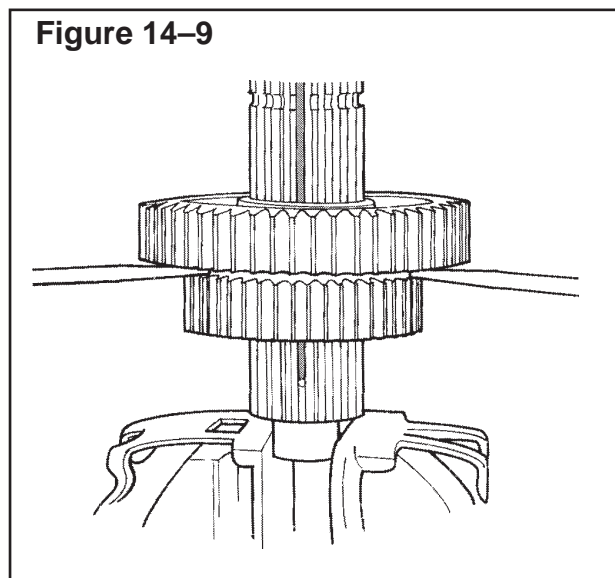

NOTE:

Do not push on the screwdrivers when the feeler gauges are installed.

- c. Put two small feeler gauges between the hubs. Each feeler gauge must be opposite the other. The clearance must be 0.006-0.012 inch (0.152 mm-0.304 mm).

Figure 14–10.

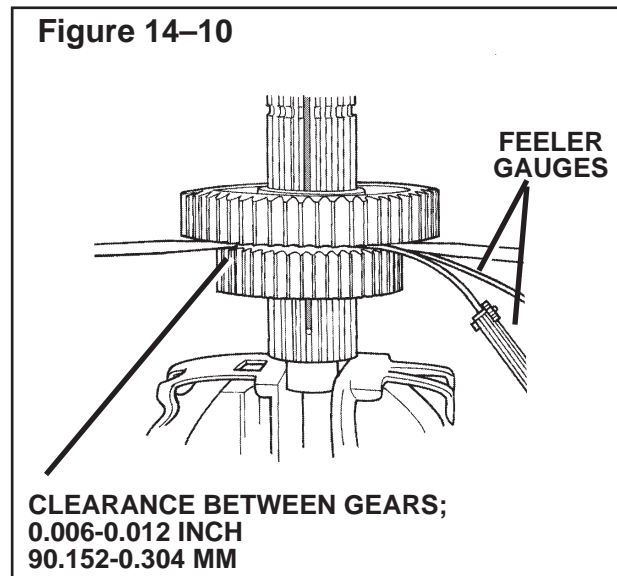

- d. If the clearance is less than 0.006 inch (0.152 mm), install a thinner selective thrust washer in the second or the third gear.

If the clearance is more than 0.012 inch (0.304 mm), install a thicker selective thrust washer.

Three sizes of thrust washers are available.

For transmissions with serial numbers LB93021753, the sizes are: 0.216, 0.220 and 0.224 inch (5.50, 5.60 and 5.70 mm).

For transmissions with serial numbers LB93021754 and above, the sizes are: 0.272, 0.275 and 0.279 inch (6.90, 7.00 and 7.10 mm).

Section 14

Overhauling the Mainshaft

- e. Remove the screwdrivers and feeler gauges.
17. Install the sliding collar. Make sure the slot in the collar is installed over the key. **Figure 14–11.**

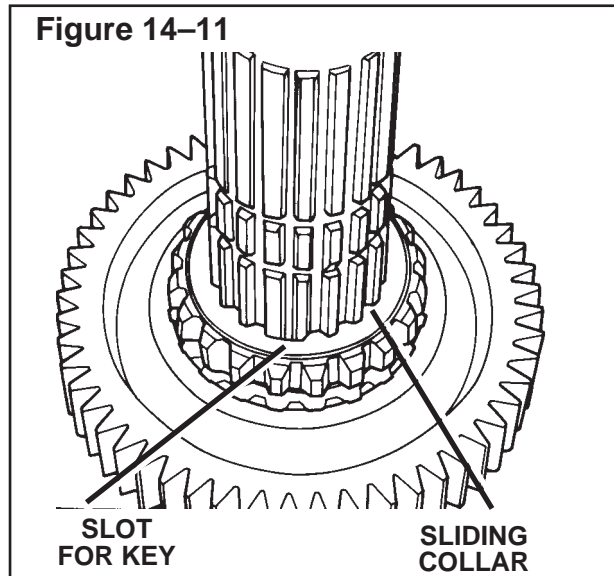

CAUTION

Use the correct selective washer. Do not mix washers or the transmission will not operate correctly.

18. Choose the correct selective thrust washer for the first or second gear. See the following.
- If the selective washers **are not replaced**, use the original washers.
 - If the selective washers **are replaced**, install the medium size of washer.

For transmissions with serial numbers LB93021753 and below, use a 0.220 inch (5.60 mm) washer.

For transmissions with serial numbers LB93021754 and above, use a 0.275 inch (7.00 mm) washer.

19. Remove the key. Install the selective thrust washer for the first or second gear. See the following.

Figure 14–12.

- Install the washer on the shaft. Make sure the smooth side is towards you.
- Slide the washer to the third groove above the roll pin.
- Move the washer so that the teeth of the washer are directly over the splines of the shaft. The washer must not slide down the shaft.

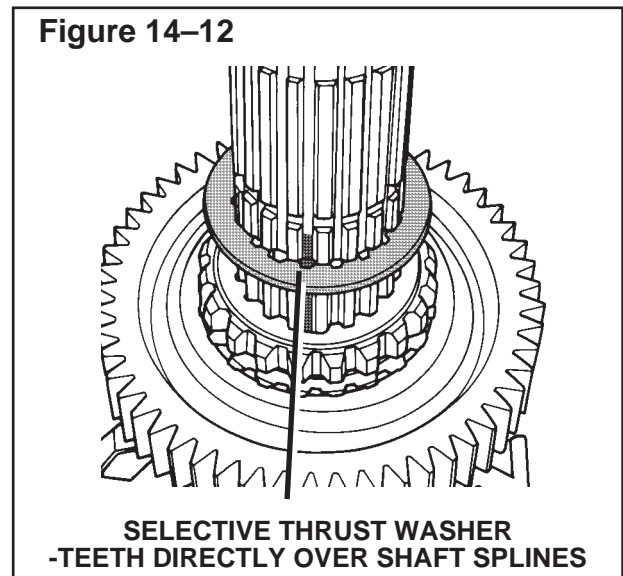

20. Install the key in the slot where the roll pin is installed. The key must touch the roll pin. **Figure 14–13.**
21. Install the spacer on top of the washer. **Figure 14–13.**

Section 14

Overhauling the Mainshaft

Figure 14-13

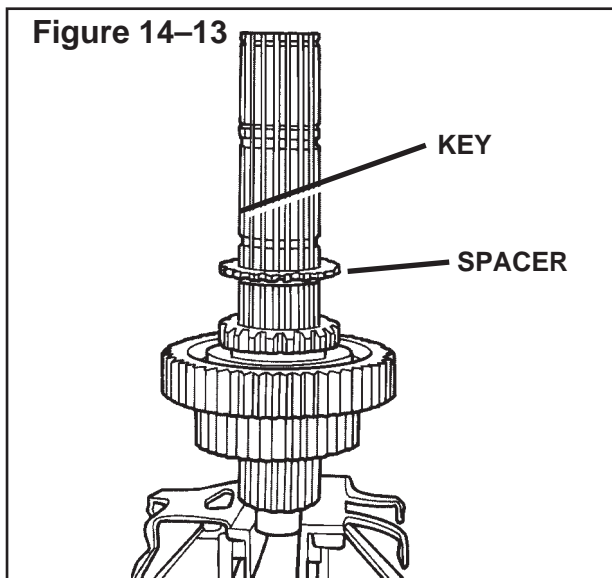

22. Install the first or second gear on the shaft. Make sure the splines of the gear engage the teeth on the spacer and the snap ring is against the spacer. **Figure 14-14.**

Figure 14-14

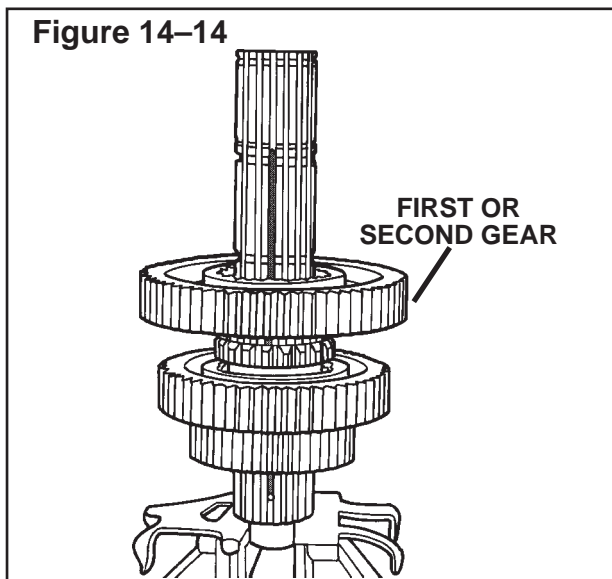

23. Install the low or first gear. Make sure the snap ring is towards the first or second gear. **Figure 14-15.**
24. Install a spacer. Make sure the teeth of the spacer engage the splines of the gear. **Figure 14-15.**

Figure 14-15

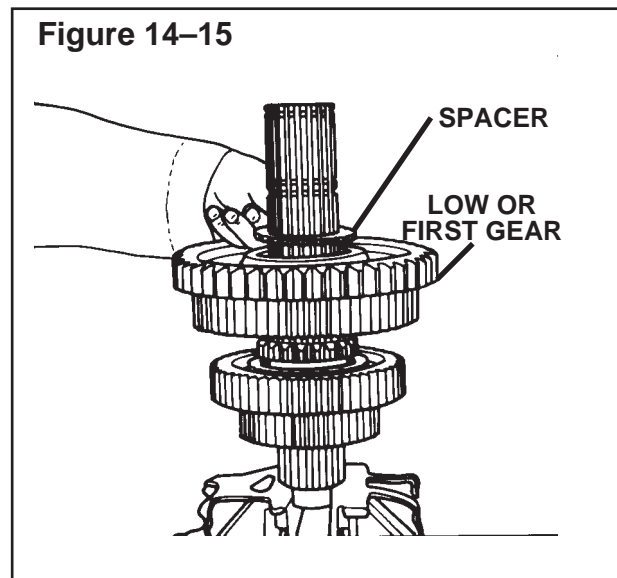

CAUTION

Make sure the selective washers do not move when the key is removed. If the washers move, the gears will fall and the assembly must be disassembled and assembled.

25. Remove the key.
26. Choose the correct selective thrust washer for the low or first gear. See the following.
- If the selective washers **are not replaced**, use the original washers.
 - If the selective washers **are replaced**, install the thinnest size of washer.

For transmissions with serial numbers LB93021753 and below, use a 0.216 inch (5.50 mm) washer.

For transmissions with serial numbers LB93021754 and above, use a 0.272 inch (6.90 mm) washer.

Section 14 Overhauling the Mainshaft

27. Install the selective thrust washer for the low or first gear. See the following. **Figure 14-16.**

- a. Install the washer on the shaft. Make sure the chamfered side with the dot is towards you.
- b. Slide the washer to the fourth groove above the roll pin.
- c. Move the washer so that the teeth of the washer are directly over the splines of the shaft. The washer must not slide down the shaft.

If necessary, put a small screwdriver in the dot on the washer to move the washer. **Figure 14-16.**

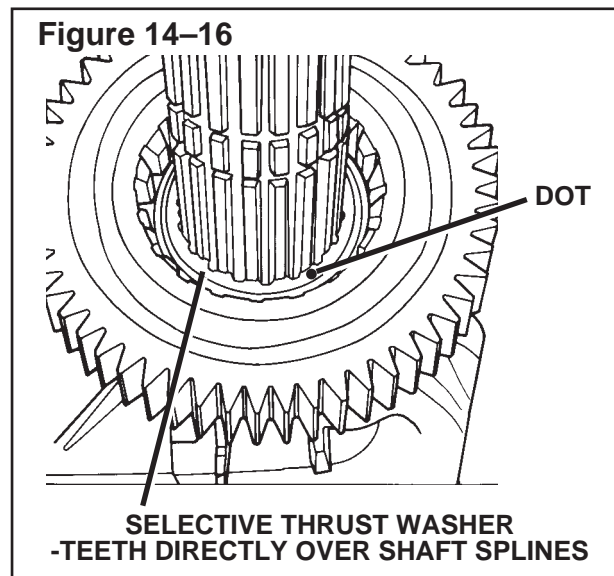

28. Check the clearance between the low or the first and the first or second gears. See the following procedure.

- a. Put two screwdrivers across from each other between the first and low or the second and the first gears. **Figure 14-17.**
- b. Lightly push on the screwdrivers to evenly spread the gears. Make sure the gears are parallel. **Figure 14-17.**

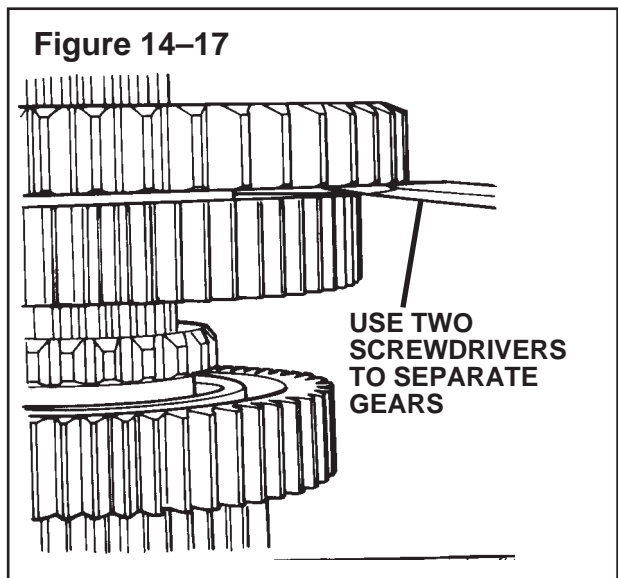

NOTE

Do not push on the screwdrivers when the feeler gauges are installed.

- c. Put two feeler gauges between the hubs. Each feeler gauge must be opposite the other. The clearance must be 0.006-0.012 inch (0.152 mm-0.304 mm). **Figure 14-18.**

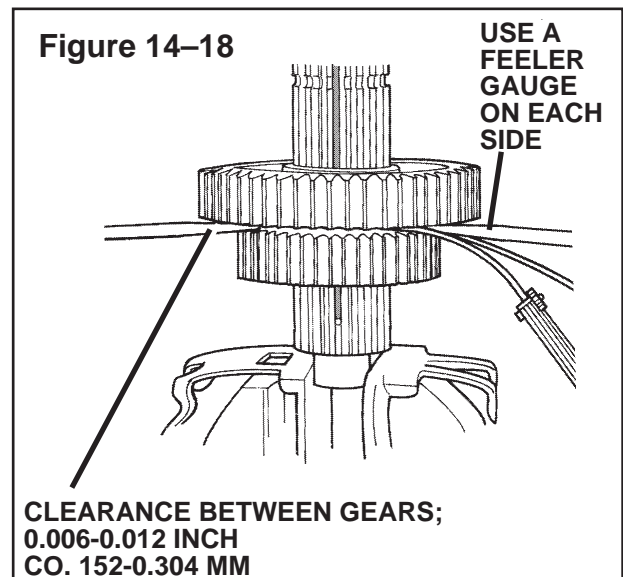

Section 14

Overhauling the Mainshaft

- d. If the clearance is less than 0.006 inch (0.152 mm), install a thinner selective washer.

If the clearance is more than 0.012 inch (0.304 mm), install a thicker selective washer.

Three sizes of thrust washers are available.

For transmissions with serial numbers LB93021753, the sizes are: 0.216, 0.220 and 0.224 inch (5.50, 5.60 and 5.70 mm).

For transmissions with serial numbers LB93021754 and above, the sizes are: 0.272, 0.275 and 0.279 inch (6.90, 7.00 and 7.10 mm).

- e. Remove the screwdrivers and feeler gauges.

27. Install the sliding collar on the shaft. Make sure the slot in the collar is installed over the key. **Figure 14–19.**

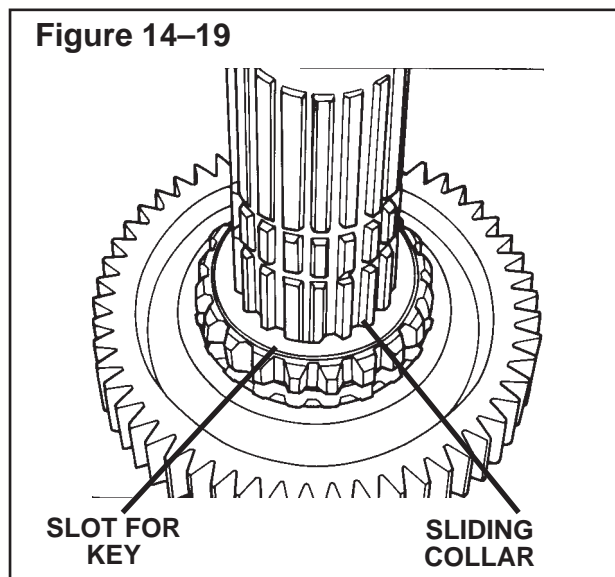

CAUTION

Use the correct selective washer. Do not mix washers or the transmission will not operate correctly.

28. Choose the correct selective thrust washer for the reverse gear. See the following.
- If the selective washers **are not replaced**, use the original washers.
 - If the selective washers **are replaced**, install the medium size of washer.
- For transmissions with serial numbers LB93021753 and below, use a 0.220 inch (5.60 mm) washer.
- For transmissions with serial numbers LB93021754 and above, use a 0.275 inch (7.00 mm) washer.
29. Remove the key. Install the selective thrust washer for the reverse gear. See the following. **Figure 14–20.**
- a. Install the washer on the shaft. Make sure the smooth side is towards you.
 - b. Slide the washer to the fifth groove above the roll pin.
 - c. Move the washer so that the teeth of the washer are directly over the splines of the shaft. The washer must not slide down the shaft.

Section 14 Overhauling the Mainshaft

Figure 14-20

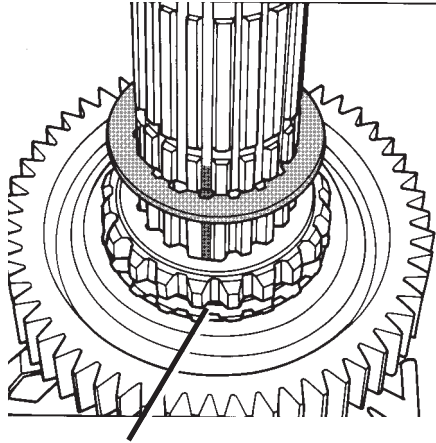

**SELECTIVE THRUST WASHER
-TEETH DIRECTLY OVER SHAFT SPLINES**

30. Install the key in the slot where the roll pin is installed. Make sure the key touches the roll pin. **Figure 14-21.**

Figure 14-21

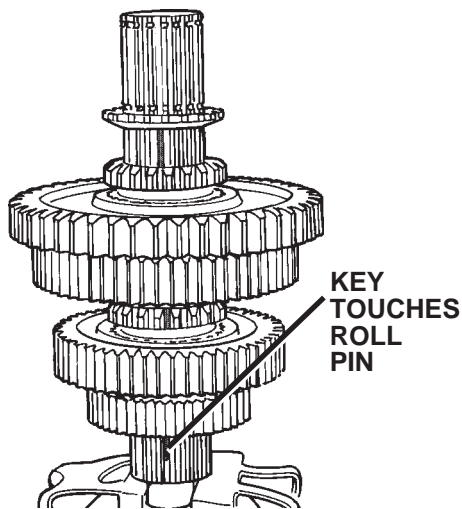

31. Install the spacer on top of the washer. **Figure 14-22.**

Figure 14-22

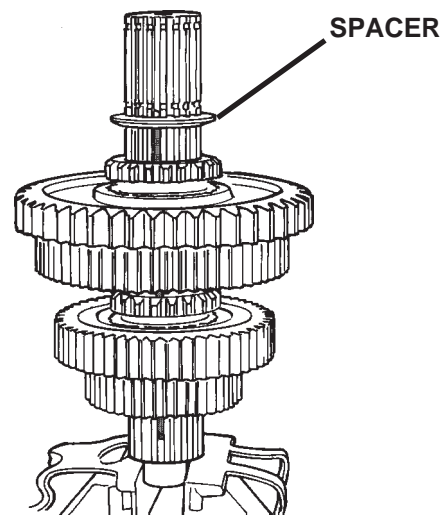

32. Install the reverse gear on the shaft. Make sure the splines in the gear engage the teeth in the spacer and the snap ring is against the spacer. **Figure 14-23.**

Figure 14-23

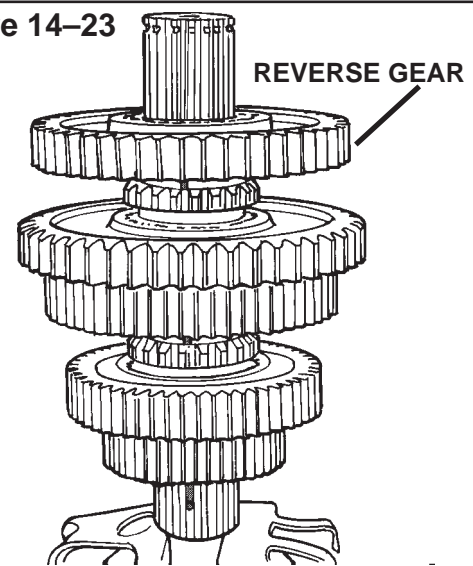

33. Install the snap ring in the second snap ring groove from the top of the mainshaft. Make sure the opening of the snap ring is opposite (180°) the key. **Figure 14-24.**

Section 14

Overhauling the Mainshaft

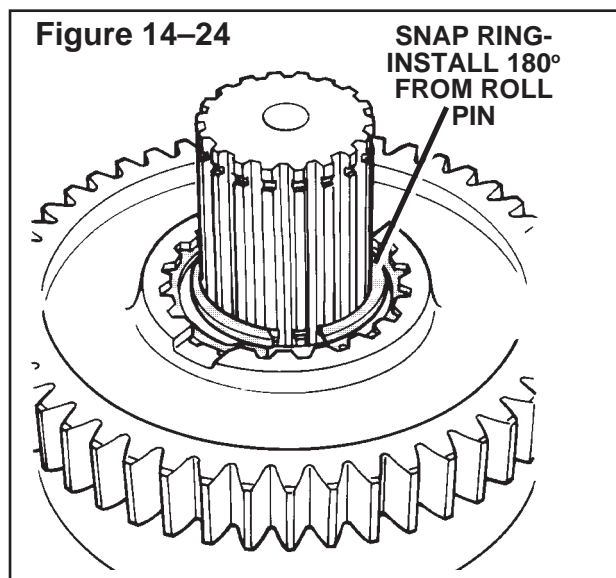

34. Install the thrust washer for the auxiliary drive gear on the mainshaft in the second groove from the top of the mainshaft. **Figure 14-25.**

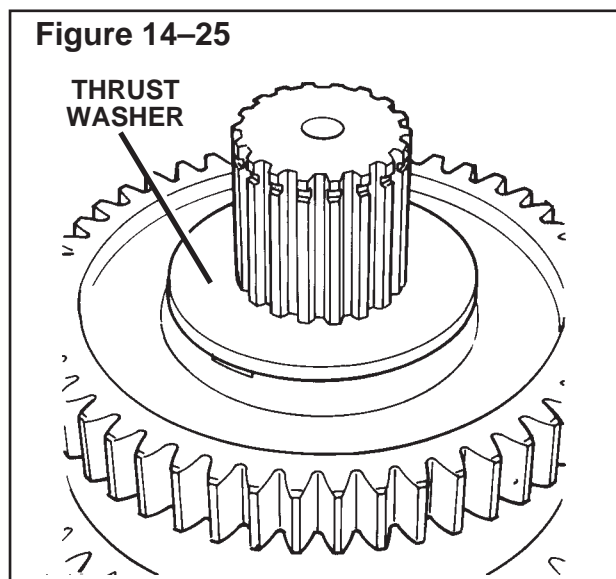

35. Install the auxiliary drive gear assembly on the mainshaft. Make sure the bearing is installed toward the mainshaft. **Figure 14-26.**
36. Install the snap ring that fastens the auxiliary drive gear to the mainshaft. **Figure 14-26.**

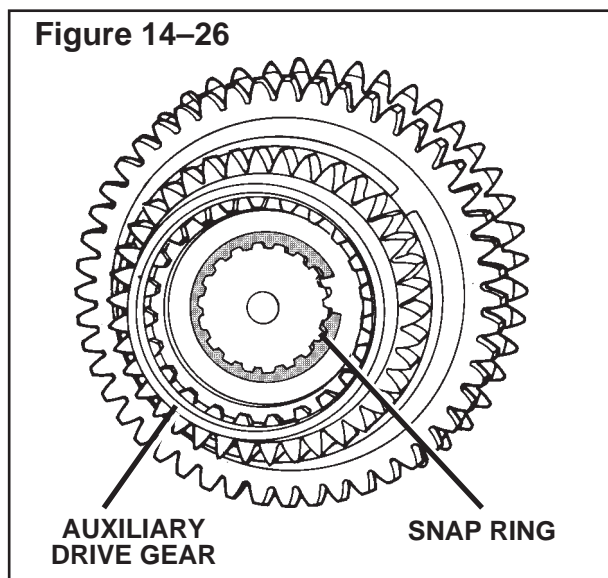

37. Check the clearance between the auxiliary drive gear and the reverse gear. See the following procedure.
- Lift on the auxiliary drive gear and push on the reverse gear. Make sure the auxiliary drive gear is parallel to the reverse gear. Make sure the snap rings are correctly installed. **Figure 14-27.**

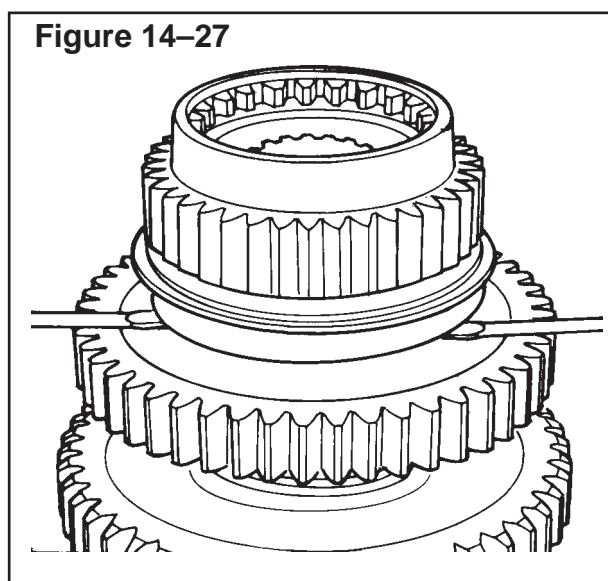

Section 14

Overhauling the Mainshaft

- b. Put a two feeler gauges between the hubs. The clearance must be 0.006-0.012 inch (0.152 mm-0.304 mm). **Figure 14-28.**

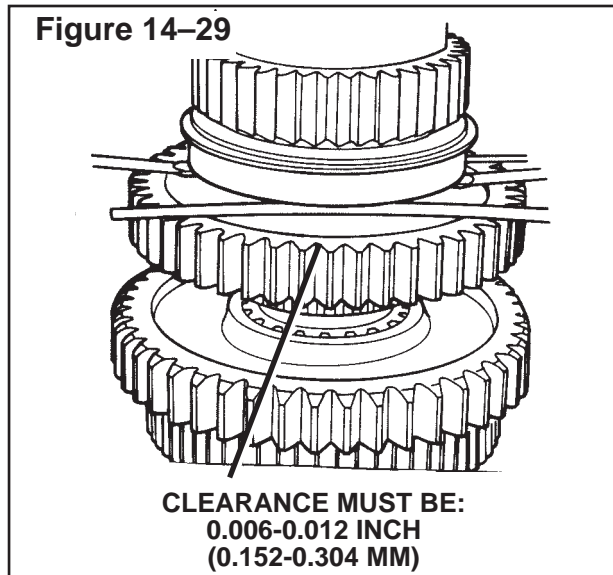

- c. If the clearance is less than 0.006 inch (0.152 mm), install a thinner selective washer in the reverse gear.
- d. If the clearance is more than 0.012 inch (0.304 mm), install a thicker selective washer in the reverse gear.

Three sizes of thrust washers are available.

For transmissions with serial numbers LB93021753, the sizes are: 0.216, 0.220 and 0.224 inch (5.50, 5.60 and 5.70 mm).

For transmissions with serial numbers LB93021754 and above, the sizes are: 0.272, 0.275 and 0.279 inch (6.90, 7.00 and 7.10 mm).

- e. Remove the screwdrivers and feeler gauges.

38. Remove the mainshaft assembly from the vise.
39. Install the sliding collar over the roll pin on the top of the mainshaft.



CAUTION

Be careful when moving the mainshaft assembly. The movement of the gears can damaged the washers.

Section 15

Overhauling the Main Countershafts

Disassembling the Upper and the Lower Main Countershaft Assemblies

See Figure 15-1.

Figure 15-1

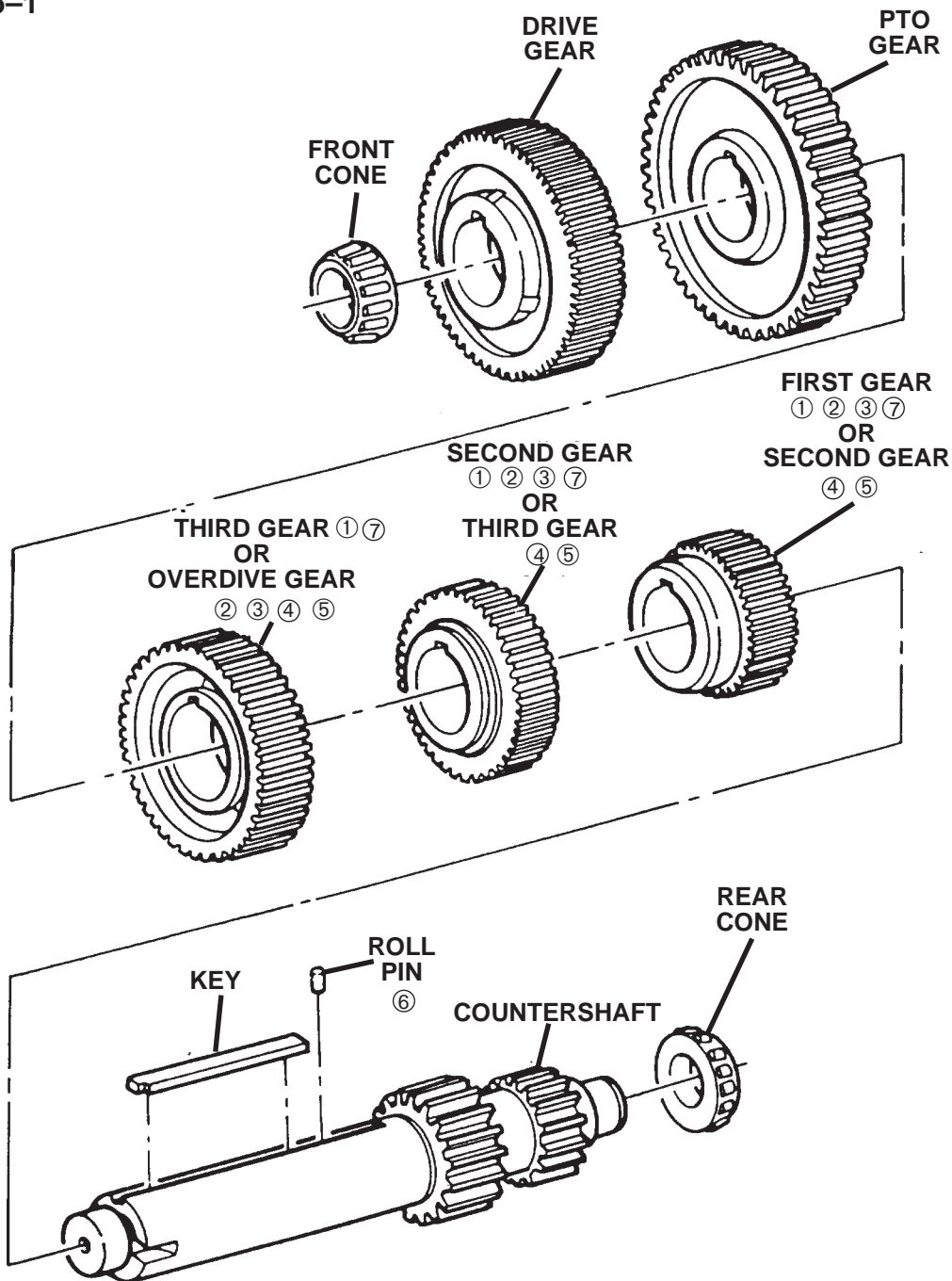

APPLICATIONS

- ① 9-SPEED DIRECT DRIVE TRANSMISSIONS
- ② 9-SPEED "A" RATIO OVERDRIVE TRANSMISSIONS
- ③ 9-SPEED "B" RATIO OVERDRIVE TRANSMISSIONS

- ④ 9-SPEED "R" RATIO OVERDRIVE TRANSMISSIONS
- ⑤ 10-SPEED OVERDRIVE TRANSMISSIONS
- ⑥ 9-SPEED DESIGN LEVEL 1 TRANSMISSIONS
- ⑦ 13-SPEED TRANSMISSION

Section 15

Overhauling the Main Countershaft



WARNING

To prevent serious eye injury, always wear safe eye protection when doing maintenance or service.

NOTE:

The upper and lower main countershafts are serviced in the same way.

NOTE:

See Figure 15-1 to identify the components of the countershaft assembly for the transmission models.

1. If necessary, remove the front and rear countershaft bearings. See the following.
 - a. **Puller Method-Rear Bearing.**
Put a step plate on the countershaft. Install a puller tool so that the jaws of the puller are under the race of the cone. Remove and discard the cone. **Figure 15-2.**

Figure 15-2

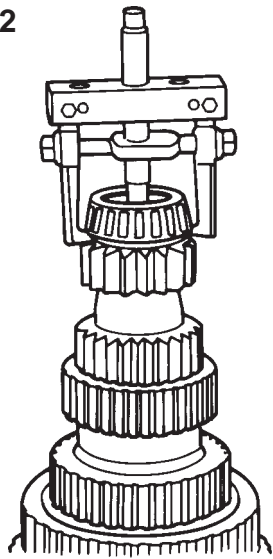

- b. **Press Method-Front Bearing.**
Do steps 2 and 3 of this procedure.
- c. **Press Method-Rear Bearing.**
Put a splitter tool under the race of the cone. Support the countershaft on the splitter tool. Put a sleeve

that fits inside the diameter of the countershaft. Press the countershaft from the cone. Discard the cone. **Figure 15-3.**

Figure 15-3

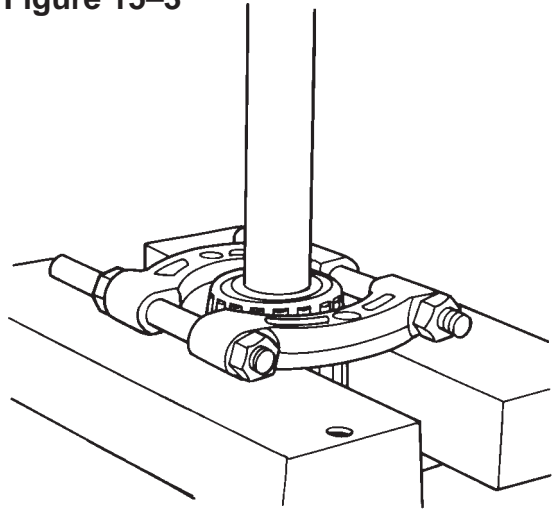

2. Put the countershaft in a press so that the main drive gear is toward the top of the press. Support the countershaft on the third or overdrive gear assembly. **Figure 15-4.**
3. Put a sleeve on the top of the shaft. Press the shaft from the third or the overdrive gear, the PTO gear and the main drive gear. **Figure 15-4.**

Figure 15-4

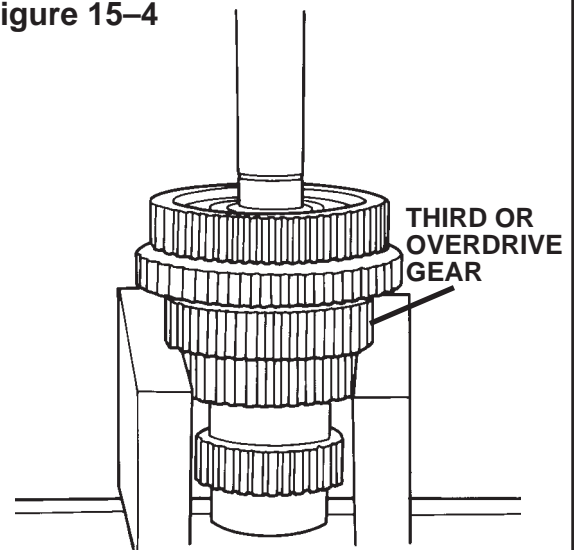

Section 15

Overhauling the Main Countershafts

- Support the countershaft on the first or second gear. Put a sleeve on top of the shaft. Press the shaft from the second or the third gear and the first or the second gear. **Figure 15-5.**

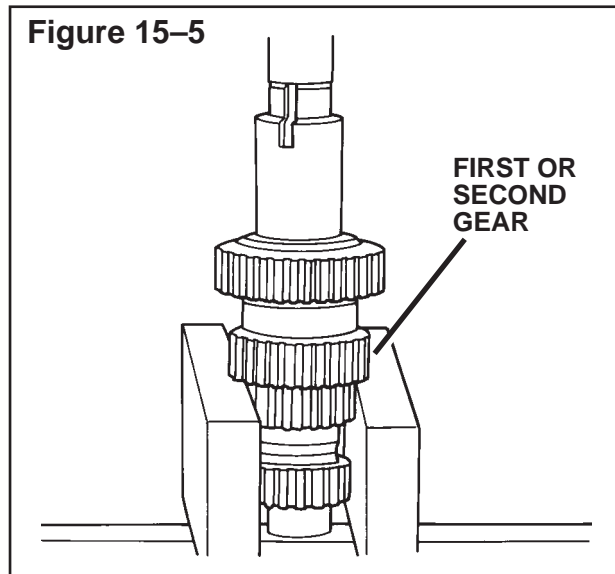

- Remove the key from the groove in the shaft. **Figure 15-6.**
- On Design Level 1 Transmissions,** remove the roll pin from the shaft. **Design Level 2 Transmissions** do not use a roll pin. **Figure 15-6.**
- Inspect all parts. See "Inspecting the Parts" in Section 1.

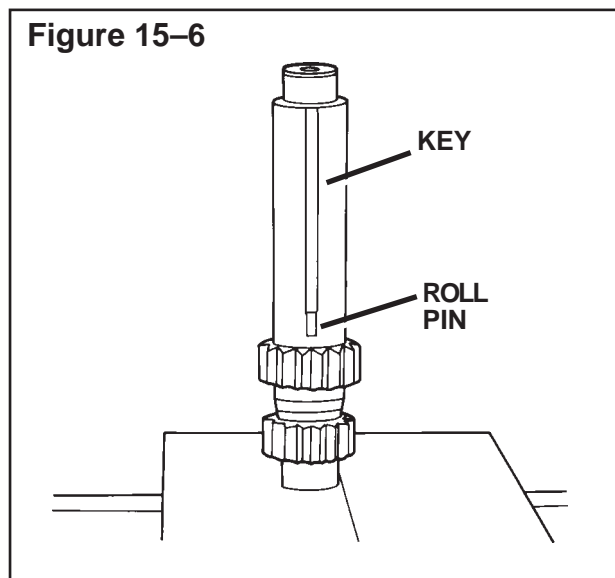

Assembling the Upper and the Lower Main Countershaft Assemblies

NOTE:

The upper and lower countershafts are each serviced in the same way.

NOTE:

See Figure 15-1 to identify the components of the countershaft assembly for the transmission models.

- Lubricate all the parts with new oil that is used in the transmission.
- On Design Level 1 Transmissions,** install the roll pin in the hole in the groove for the key. **Figure 15-6.**

WARNING

Wear safe eye protection and make sure the tools are in safe condition. If the tools are worn or damaged ("mushroomed"), pieces can break and cause serious personal injury.

- Use a punch and a hammer to install the key in the groove. **On Design Level 1 Transmissions,** make sure the taper on the end of the key is installed toward the roll pin. **Figure 15-6.**
- Put the first or the second gear on a press so that the hub is toward the bottom of the press. Put the shaft in the gear. Make sure the slot in the gear is aligned with the key. Put a sleeve on the top of the shaft. Press the shaft until the first gear touches the gear on the countershaft. **Figure 15-7.**

Section 15

Overhauling the Main Countershaft

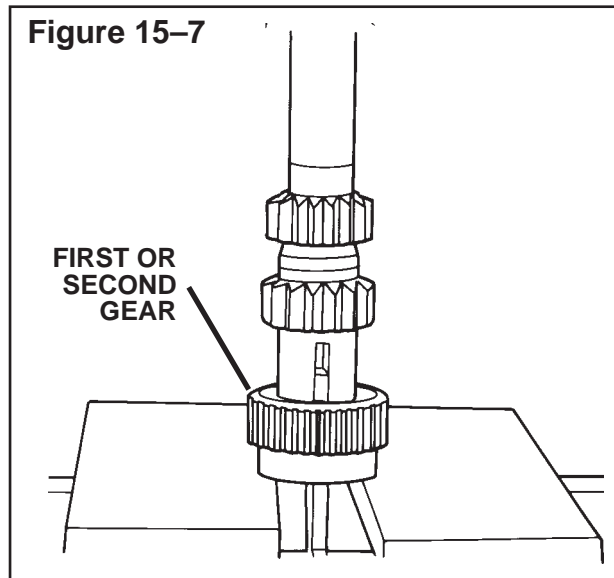

5. Put the second or the third gear on a press. Put the shaft in the gear. Make sure the slot in the gear is aligned with the key. Put a sleeve on the shaft. Press the shaft until the hub of the second gear touches the hub of the first gear. **Figure 15-8.**

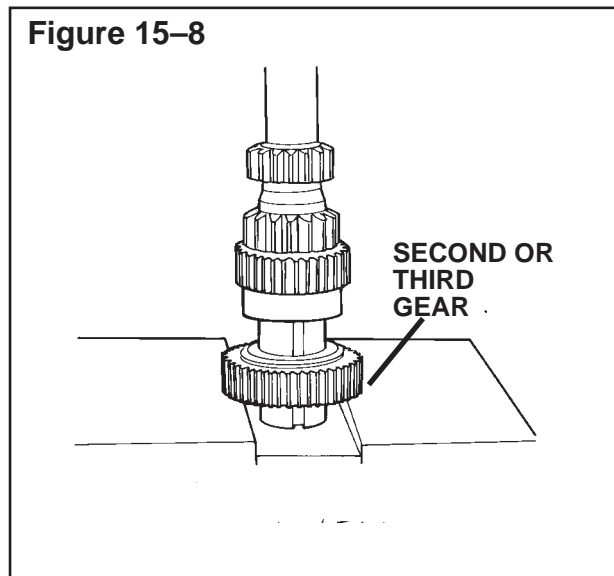

6. Put the third or the overdrive gear on a press so that the hub is away from the top of the press. Put the shaft in the gear. Make sure the slot in the gear is aligned with the key. Put a sleeve on the shaft. Press the shaft until the hub of the third gear touches the hub of the second gear. **Figure 15-9.**

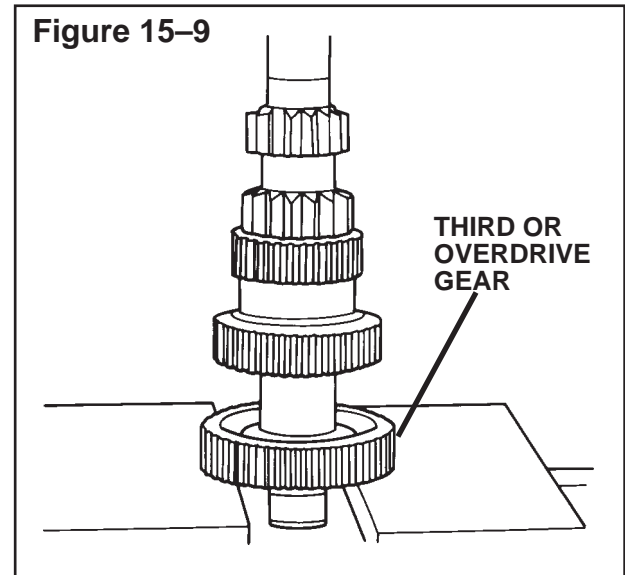

7. Put the PTO gear on the press so that the chamfered side of the teeth are toward from the top of the press. Put the shaft in the gear. Make sure the slot in the gear is aligned with the key in the shaft. Press the PTO gear on the shaft until the PTO hub touches the hub of the third or overdrive gear.
8. Put the main drive gear on a press so that the large hub of the gear is toward the PTO gear. Put the shaft in the gear. Make sure the slot in the gear is aligned with the key in the shaft. Put a sleeve on the top of the shaft. Press the shaft into the gear until the hub of the main drive gear touches the hub of the PTO gear. **Figure 15-10.**

Section 15

Overhauling the Main Countershafts

Figure 15-10

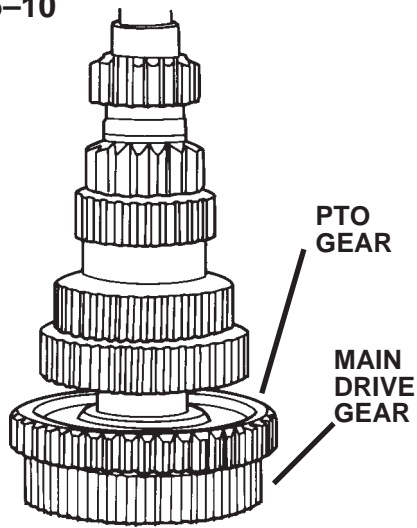

CAUTION

Use the bearing inner race for installation. If pressure is applied to the bearing cage, the bearing will be damaged.

9. Install the front and rear countershaft bearing cones in one of the following ways.
 - Use a sleeve or a bearing installation tool to install the cones. Make

sure the bottom of the cone touches the shoulder on the shaft.
Figure 15-11.

WARNING

Follow the instructions of the manufacturer of the bearing heater. The heated cones can burn you.

- Use a bearing heater to install the cones on the shaft. Make sure the bottom of the cone touches the shoulder on the shaft.

Figure 15-11

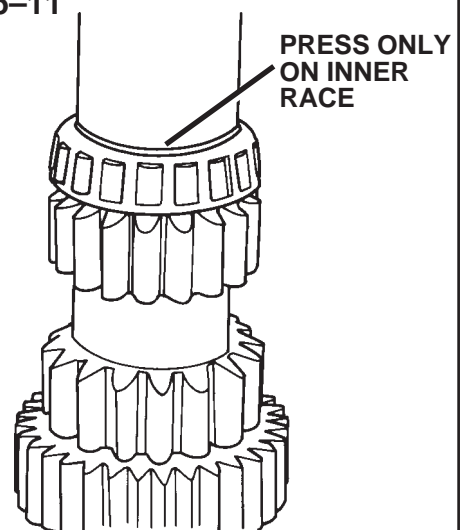

Disassembling the Auxiliary Case - Nine- and Ten-Speed Transmissions

See Figure 16-1.

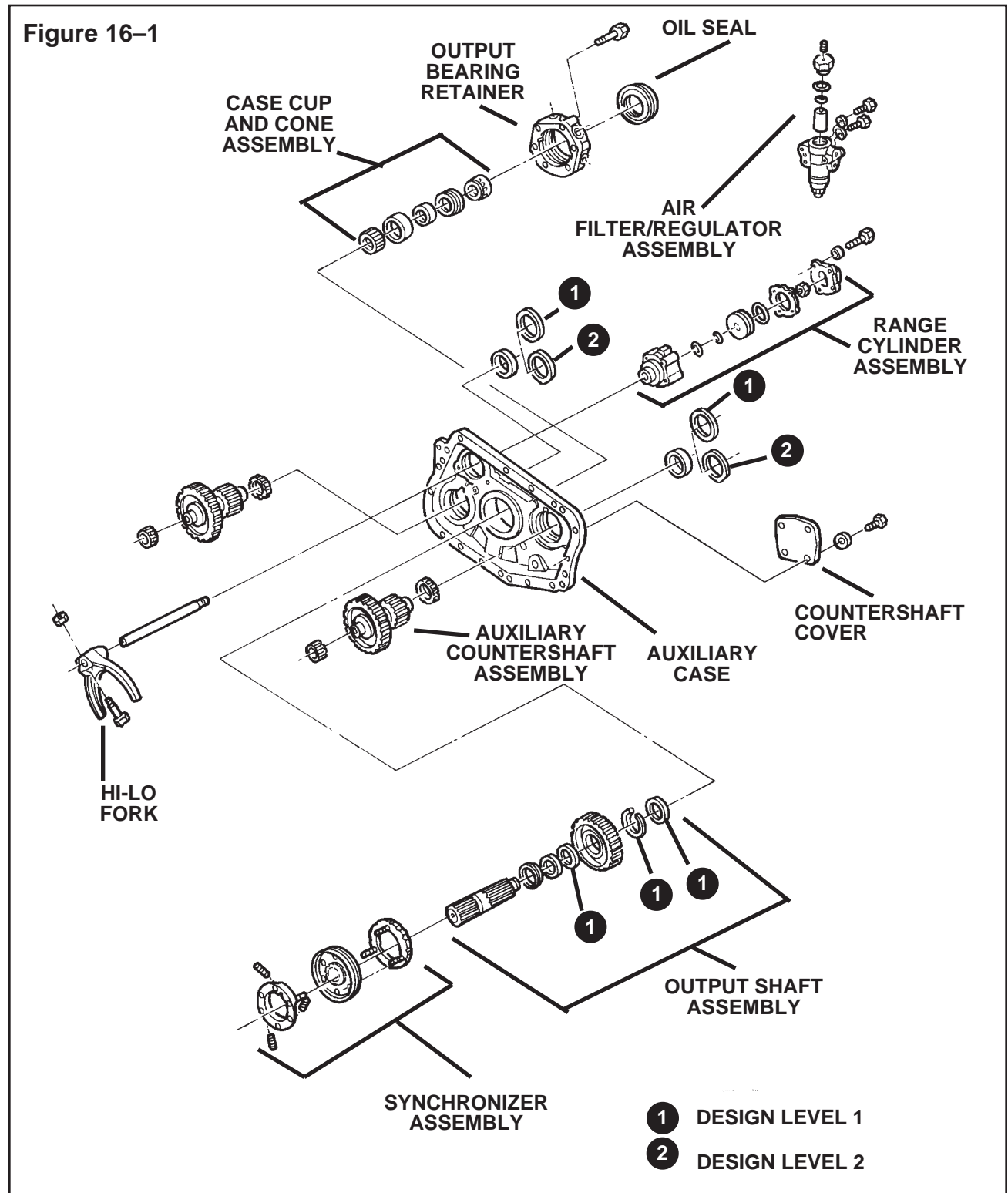

Section 16 Overhauling the Auxiliary Case

Nine-Speed and Ten-Speed Transmissions

! WARNING

To prevent serious eye injury, always wear safe eye protection when doing maintenance or service.

1. If necessary, remove the air filter/regulator assembly from the range cylinder cover.
2. Remove the capscrews and washers from the range cylinder cover. Remove the range cylinder cover. **Figure 16-2.**

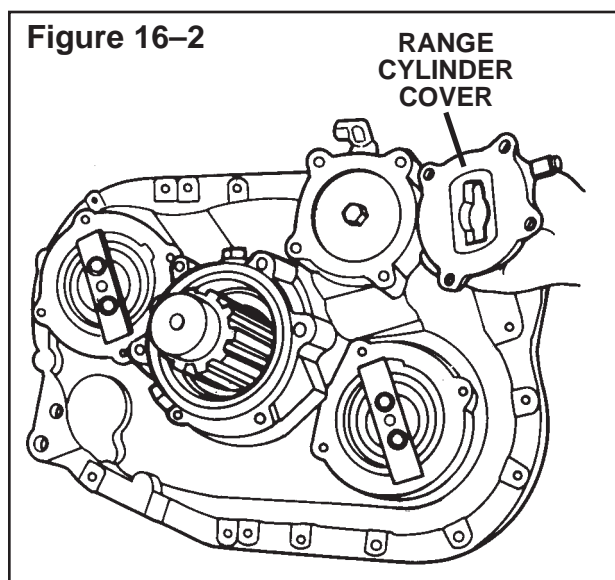

3. Remove and discard the gasket between the range cylinder cover and the range cylinder housing. **Figure 16-3.**
4. Remove the nut from the piston in the range cylinder housing. **Figure 16-3.**

Figure 16-3

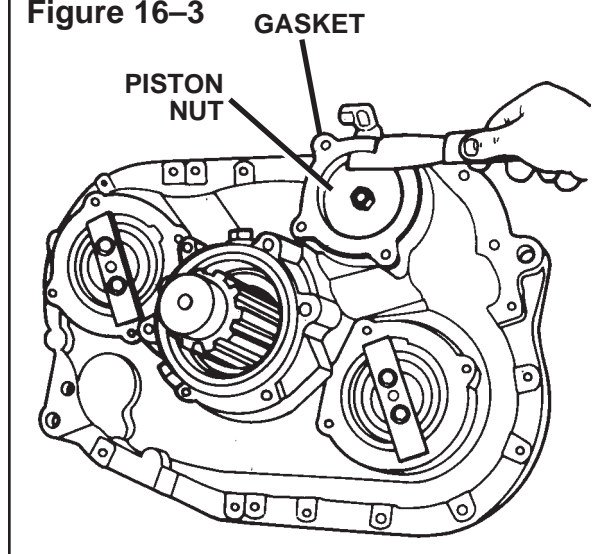

! WARNING

If necessary, use a safe amount of air pressure at the LO range port to remove the piston from the range cylinder. If too much air pressure is used, the piston will come out of the housing with enough force to cause serious personal injury.

5. Remove the piston from the bore of the range cylinder. Inspect the large O-ring on the outer diameter of the piston. If worn or damaged, remove and replace the O-ring. **Figure 16-4.**

Inspect the small O-ring in the inner diameter of the piston bore. If worn or damaged, remove and replace the O-ring. **Figure 16-4.**

Inspect the piston, especially the outer diameter for wear and damage. If worn or damaged, replace the piston and the housing as an assembly.

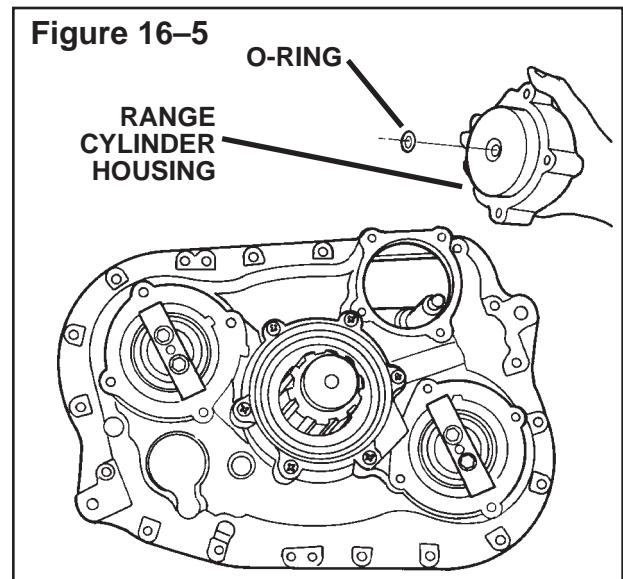
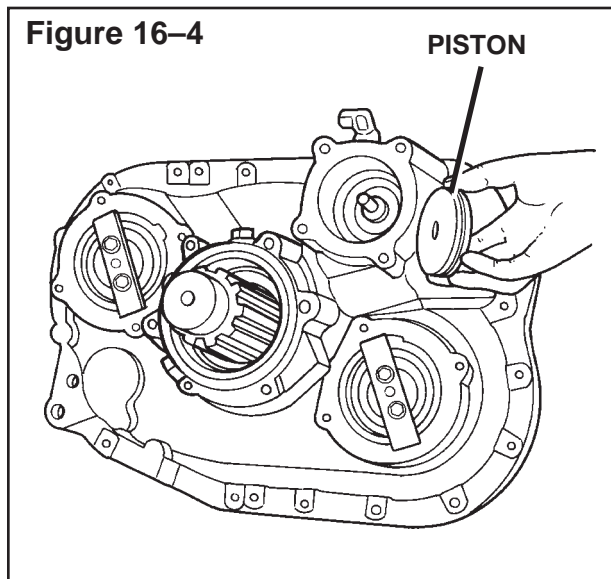

NOTE:

An O-ring is used between the range cylinder housing and the auxiliary cover on Design Level 1 Nine-Speed Transmissions. Replace with gasket sealant during assembly.

6. Remove the range cylinder housing from the cover. Inspect the O-ring in the bore for the shift shaft. Replace, if damaged. If used, remove and replace the O-ring between the housing and the auxiliary case with sealant with sealant during assembly.

Figure 16-5.

Inspect the range cylinder housing, especially the bore for wear and damage. If worn or damaged, replace the piston and the housing as an assembly

7. Remove the mounting capscrews and washers from the output bearing retainer to the auxiliary cover. Remove the retainer. Use a scraper to remove the sealant material from the cover and the retainer. **Figure 16-6.**
8. Inspect the oil seal in the output bearing retainer. If the seal is worn or damaged, remove and replace the seal. **Figure 16-6.**

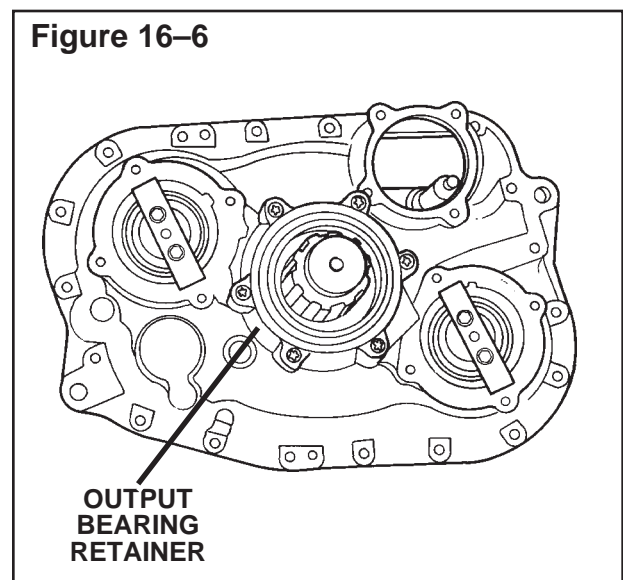

Remove the plugs from the output bearing retainer. Inspect the O-rings on the plugs. Replace worn or damaged O-rings.

9. If a mechanical speedometer is used, inspect the speedometer bushing inside the output bearing retainer. If worn or damaged, remove the bushing.
10. Remove the capscrews and the washers that fasten the holding cover tools on the auxiliary countershafts. Remove the holding cover tools.

Section 16 Overhauling the Auxiliary Case

Nine-Speed and Ten-Speed Transmissions

11. **On Design Level 1 Nine-Speed Transmissions**, remove the snap ring that fastens the upper and lower countershafts in the cover. Remove the rear bearing cups. Mark the snap rings and cups for the correct location. **Figure 16-7.**

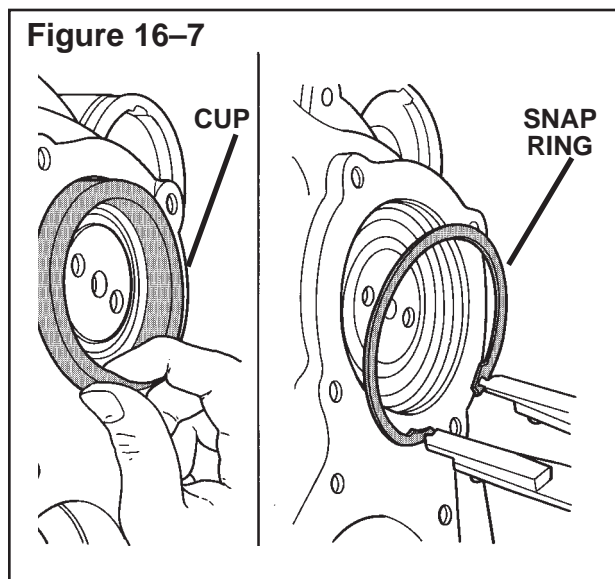

On Design Level 2 Nine-Speed and Ten-Speed Transmissions, remove the spacers for the upper and lower countershafts. Remove the rear bearing cups. Mark the spacers and the cups for correct installation. **Figure 16-8**

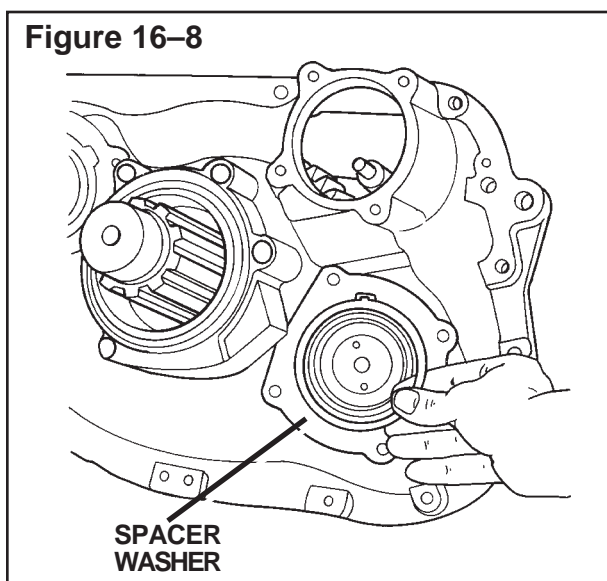

NOTE:

If a pin and a clip is used to fasten the HI-LO fork to the shift shaft, replace with a nut and shoulder bolt during assembly.

12. Remove the shoulder bolt and the nut (or pin and clip) that fastens the HI-LO fork to the shift shaft. **Figure 16-9.**

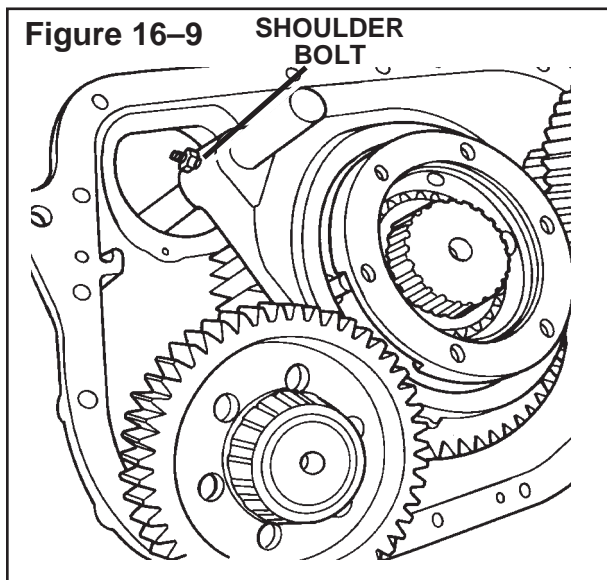

WARNING

When using a hammer and a steel drift, wear safe eye protection and make sure the tools are in safe condition. Do not use tools that are worn or damaged (“mushroomed”). If the tools are not in safe condition, pieces can break and cause serious personal injury.

13. If necessary, use a hammer and a steel drift to remove the shift shaft from the HI-LO fork. **Figure 16-10.**
14. Remove the HI-LO fork from the synchronizer collar. **Figure 16-10.**

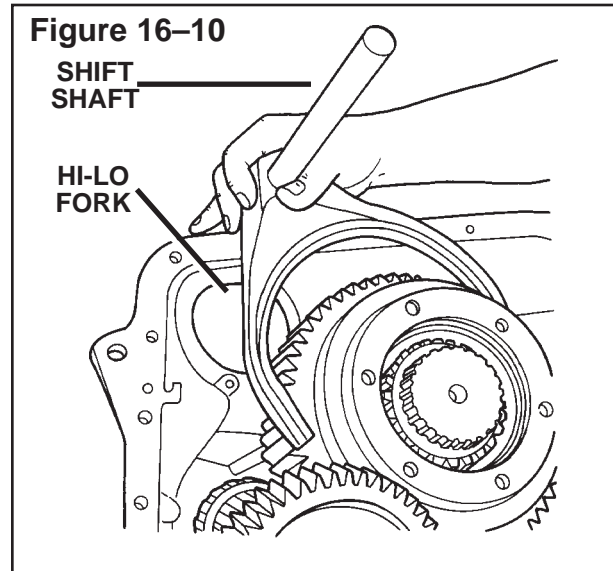

15. Remove the upper and lower auxiliary countershafts from the cover. **Figure 16-11.**
16. Remove the synchronizer assembly from the output shaft. **Figure 16-11.**

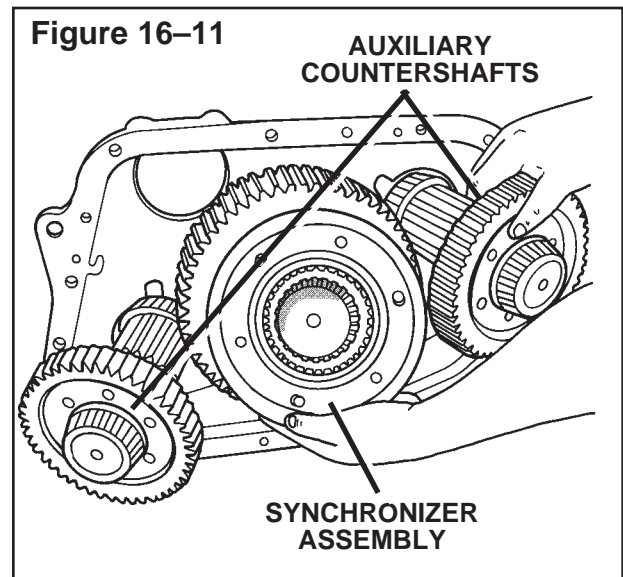

17. If worn or damaged, disassemble the synchronizer assembly. See the following procedure.

NOTE:

When separating the synchronizers, put a towel over the synchronizers to keep the springs from flying out.

- a. Pull up on the high synchronizer to separate the high synchronizer from the low synchronizer. Do not lose the springs when the synchronizers are separated.

Figure 16-12.

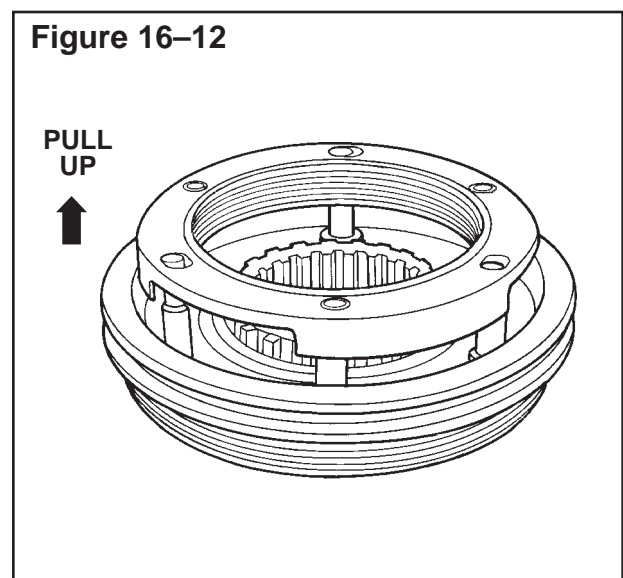

Section 16 Overhauling the Auxiliary Case

Nine-Speed and Ten-Speed Transmissions

- b. Remove the springs from the holes in the high synchronizer. **Figure 16-13.**

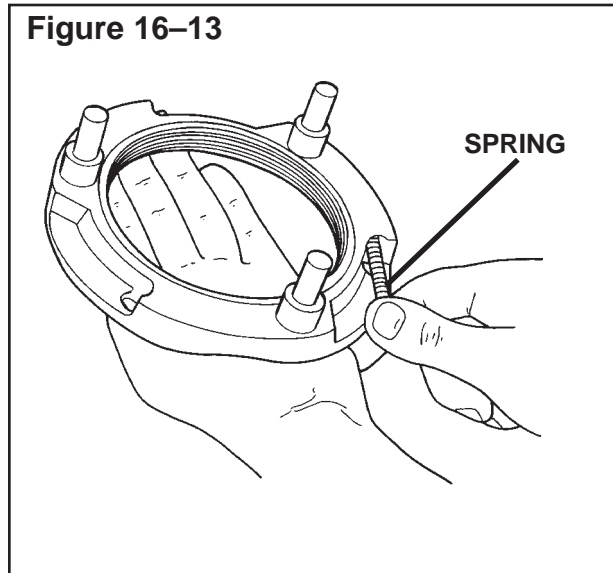

- c. Remove the collar from the low synchronizer. **Figure 16-14.**

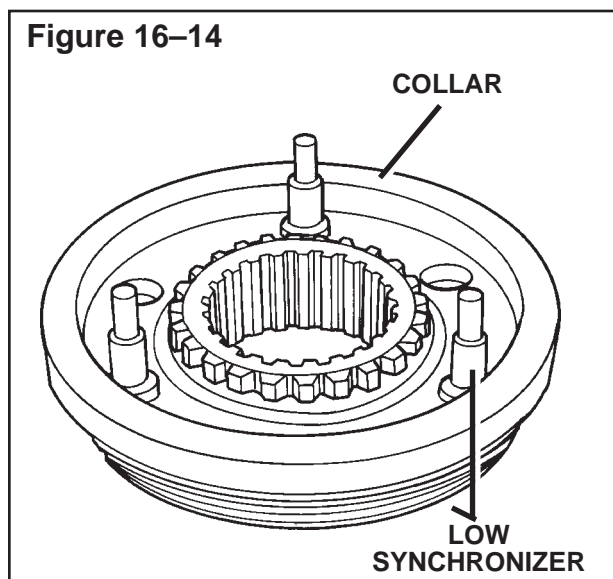

18. If worn or damaged, remove the front and rear bearing cones from the upper and lower auxiliary countershafts. Use a puller to remove the cones from the countershaft. Make sure the jaws of the puller are under the bearing races. **Figure 16-15.**

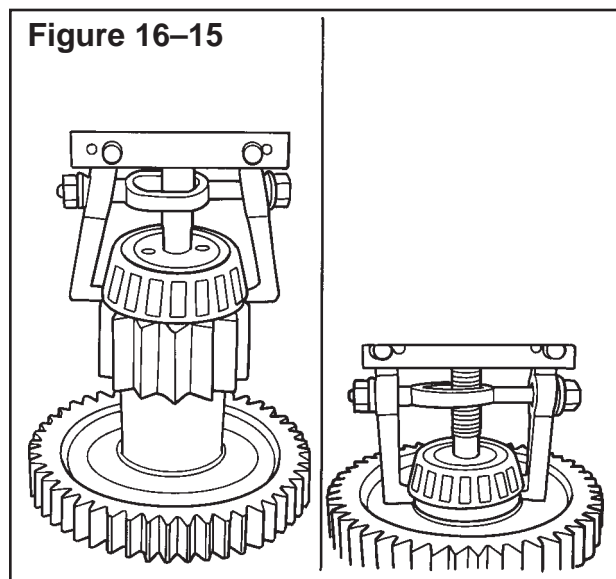

19. If necessary, remove the output shaft and the low gear assembly from the auxiliary cover. See the following procedure.

- a. Support the auxiliary cover on the low gear in a press. Make sure the output shaft is toward the top of the press. **Figure 16-16.**
- b. Put a sleeve on the top of the output shaft. Press the output shaft from the low gear assembly and the cover. **Figure 16-16.**

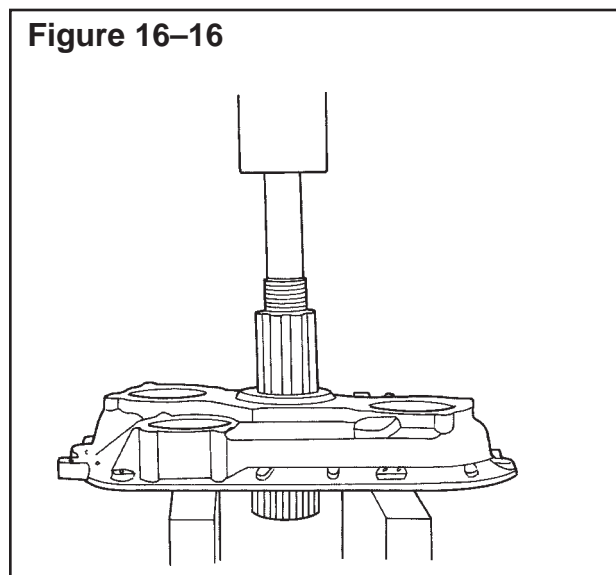

- c. Remove the outer bearing cone and the spacer from the cover. **Figure 16-17.**

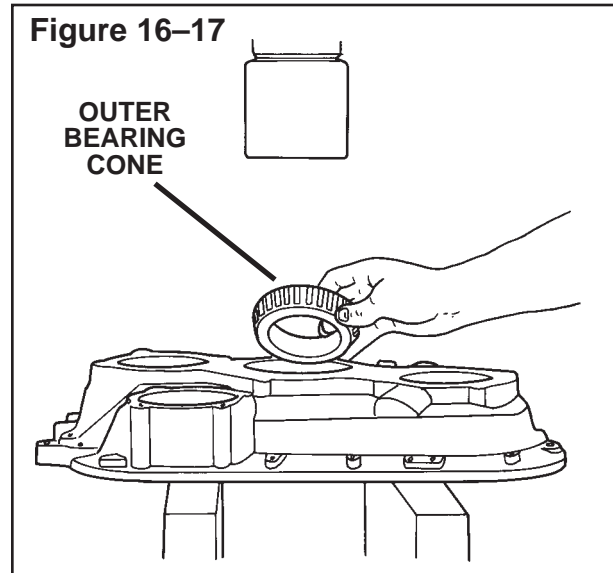

- d. Remove the cover from the press. Remove the auxiliary low gear and the inner bearing cone from the cover. **Figure 16-18.**

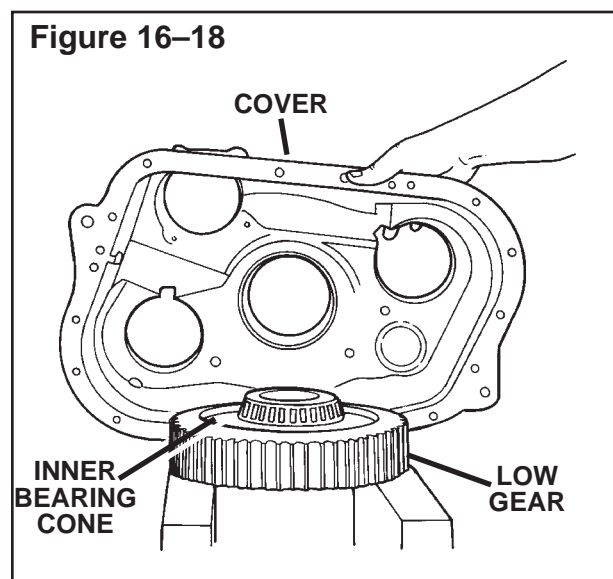

- 20. If necessary, remove the inner and the outer bearing cups for the output shaft from the auxiliary cover. See the following procedure. **Figure 16-19.**

- a. Support the case on a press. Make sure the inner surface of the case is toward the top of the press.
- b. Put a sleeve on the outer race of the inner bearing cup.
- c. Press the inner and the outer cups from the cover. Discard the cups.

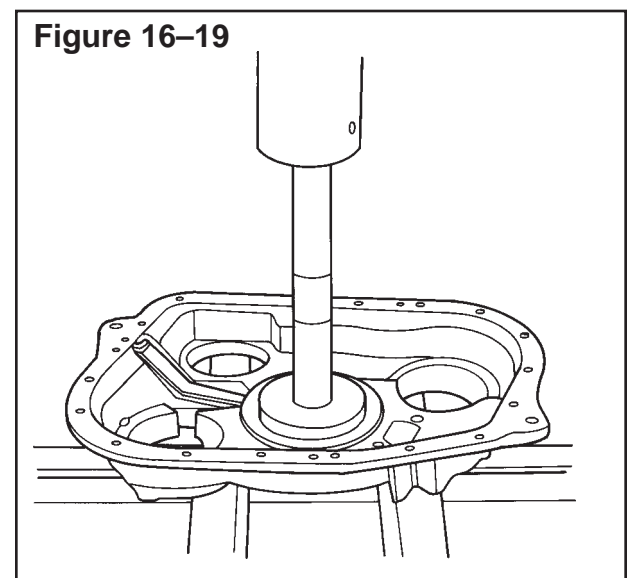

- 21. ***On Design Level 1, Nine-Speed Transmissions***, remove the toothed spacer from the output shaft or from inside the low gear. Remove the thrust washer from the top of the gear.

Section 16 Overhauling the Auxiliary Case

Nine-Speed and Ten-Speed Transmissions

NOTE:

115 and 125 series transmissions use one spacer on the output shaft. 135, 145, 155 and 165 series transmissions use two spacers on the output shaft.

22. Remove the spacer(s) from the top of the output shaft. **Figure 16-20.**
23. Inspect all parts. See "Inspecting the Parts" in Section 1.

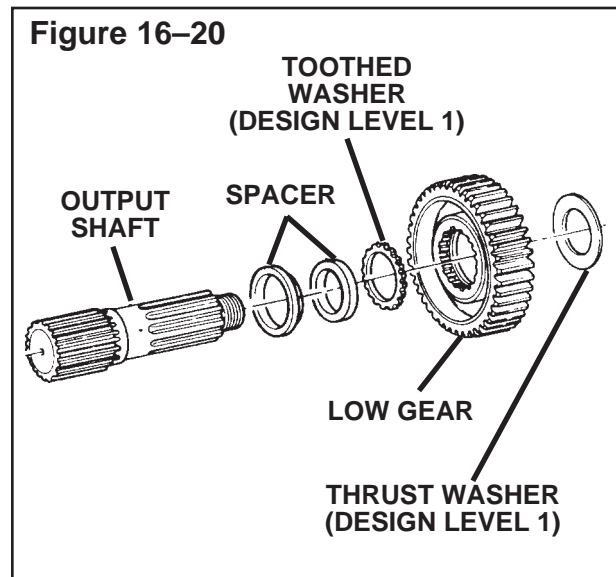

Assembling the Auxiliary Case — Nine- and Ten-Speed Transmissions

See Figure 16-1.

NOTE

The bearing cup and the bearing cone must be replaced as an assembly. Do not replace the cup or the cone separately. Replace the cup and the cone in a matched set from the same manufacturer.

1. Lubricate all the parts of the auxiliary cover with the oil used in the transmission
2. **On Design Level 1 Nine-Speed Transmissions**, if removed, install the snap ring in the groove inside the auxiliary low gear. Make sure the round side of the snap ring is installed toward the gear. **Figure 16-21.**
3. Put timing marks on the auxiliary low gear. Mark one tooth with paint. Mark a second tooth opposite (180°) the first tooth. **Figure 16-21.**

Figure 16-21

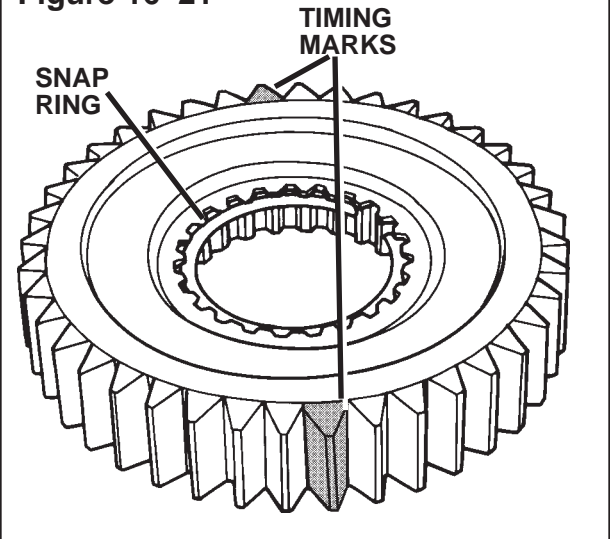

4. Use paint to put timing marks next to each other on two teeth of each countershaft low gear. Make sure the mark is aligned with the "O" stamping on the counter shaft. **Figure 16-22.**

Figure 16-22

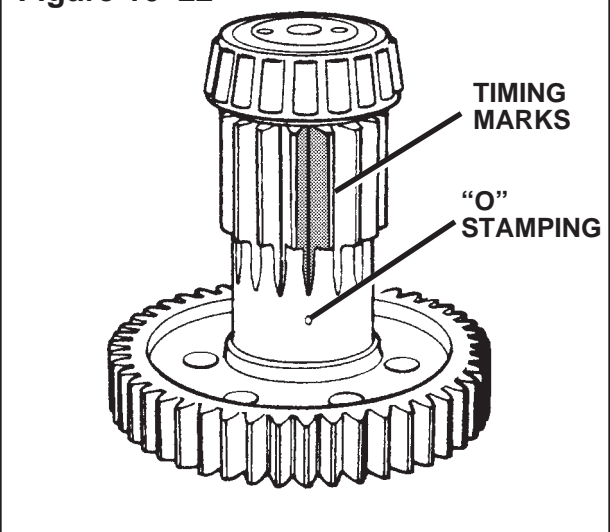

Section 16 Overhauling the Auxiliary Case

Nine-Speed and Ten-Speed Transmissions

5. Assemble the output shaft and low gear assembly according to the following procedure: **Figure 16-23**.
 - a. Put the output shaft on the work bench. Make sure the threaded end of the shaft is up.
 - b. **On Design Level 1, Model 115 and 125 Transmissions**, install the output shaft spacer with the shoulder. Make sure the spacer is installed with the large section toward the bottom of the shaft.

On Design Level 1, Model 135 and 145 Transmissions, install the output shaft spacer with the shoulder. Make sure the spacer is installed with the large section toward the bottom of the shaft. Install the small spacer on top of the spacer with the shoulder.

On Design Level 2, Model 115 and 125 Transmissions, install the flat output shaft spacer on the shaft.

Figure 16-23

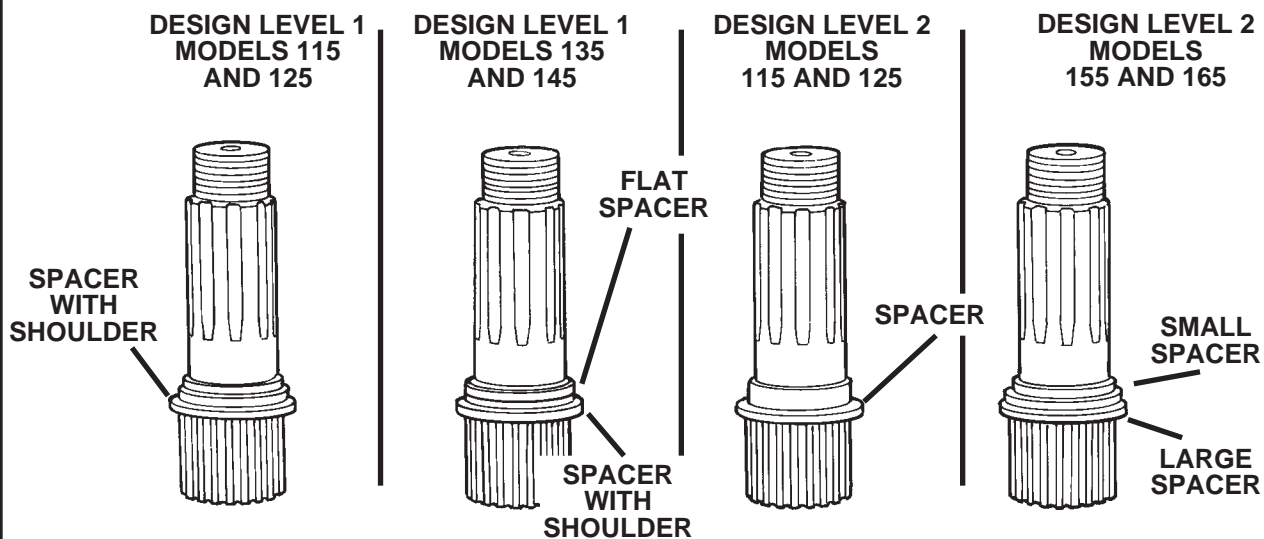
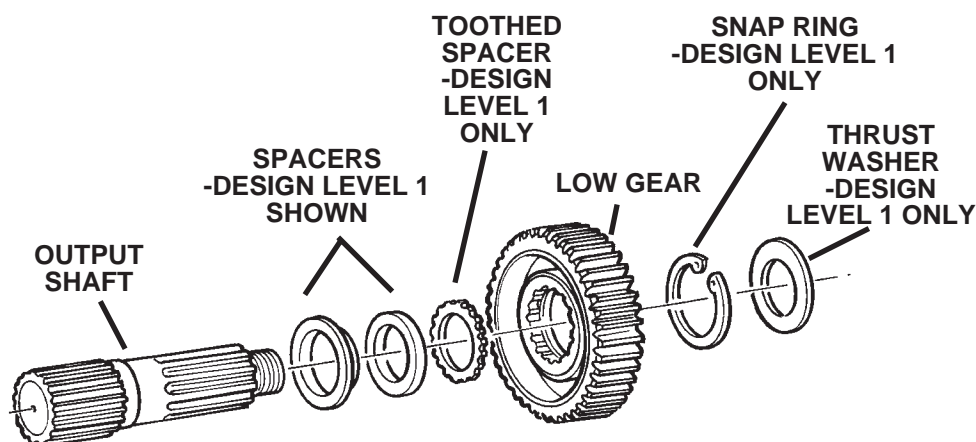

On Design Level 1, Model 135, 145, 155 and 165 Transmissions, install the large output shaft spacer on the shaft. Install the small output shaft spacer on top of the large spacer.

- c. *One Design Level 1 Nine-Speed Transmissions,* install the toothed spacer in the low gear.
- d. *One Design Level 1 Nine-Speed Transmissions,* install the snap ring in the low gear.
- e. Install the auxiliary low gear on the output shaft. **Figure 16-23.**
- f. *On Design Level 1 Nine-Speed Transmissions,* install the thrust washer on top of the low gear. **Figure 16-23.**

6. Install the bearing cone on the output shaft and low gear assembly. See the following procedure. **Figure 16-24.**

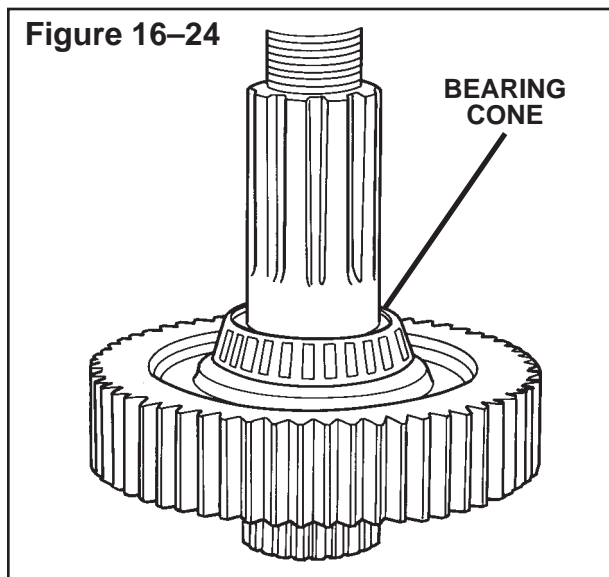

WARNING

A bearing heater can be used to install the bearing cone. Follow the instructions of the manufacturer of the bearing heater. The heated cones can burn you.

- a. Put the output shaft and low gear assembly on a press. Support the shaft on the bottom of the shaft. Make sure the threads on the shaft are toward the top of the press.
- b. Install a bearing cone on the shaft. Make sure the large diameter of the gear is toward the cone.
- c. Put a sleeve on the cone. Press the cone on the shaft until the cone touches the thrust washer or the low gear. Make sure the gear and the bearing cone rotates on the shaft.
- d. Install the spacer on the shaft. **Figure 16-25.**

Figure 16-25

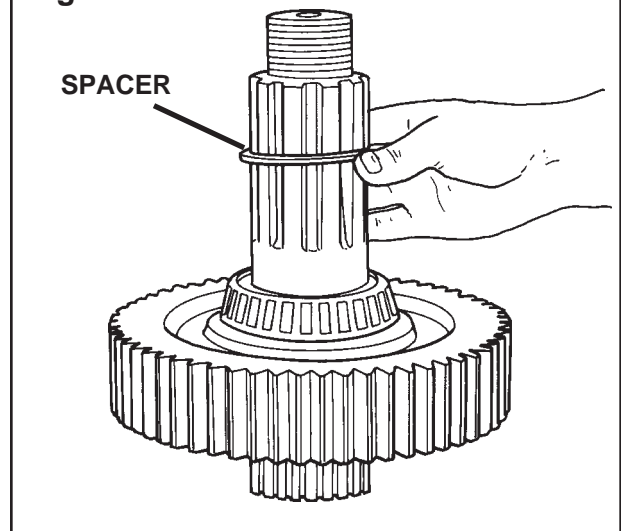

7. If removed, install the bearing cups for the output shaft in the auxiliary cover. See the following procedure.
- a. Put the cover in a press so that the outside is toward the top of the press. Support the cover under the output shaft bore. **Figure 16-26.**
 - b. Put the inner bearing cup in the cover. Make sure the letters on the cup are toward you. Install a sleeve or a bearing installation tool on the race of the bearing. **Figure 16-26.**

Figure 16-26

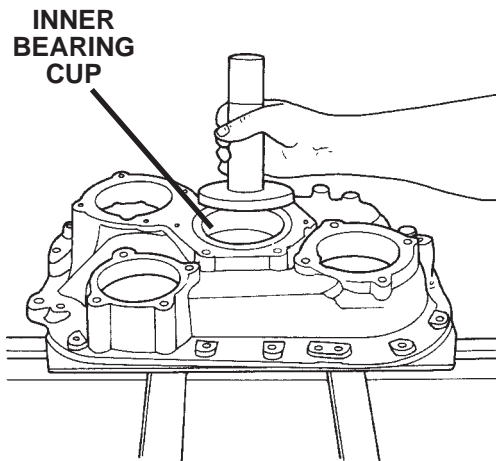

- c. Press the inner cup into the cover. **Figure 16-26.**
- d. Put the outer cup on top of the inner cup. Make sure the slots of the outer cup are against the inner cup. **Figure 16-27.**

Figure 16-27

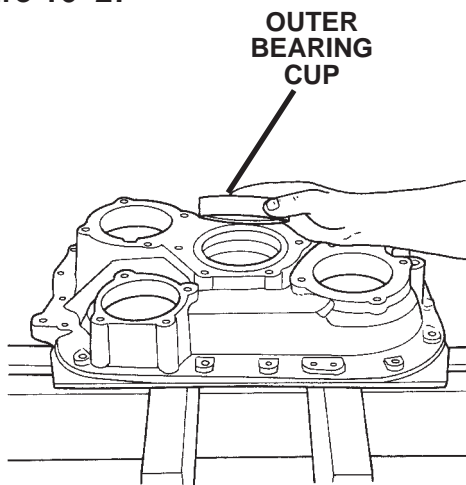

- e. Put a sleeve or installation tool on the top of the outer cup. Press both cups into the bore. The cups are correctly installed when the outer cup touches the shoulder in the bore of the cover. **Figure 16-28.**

Figure 16-28

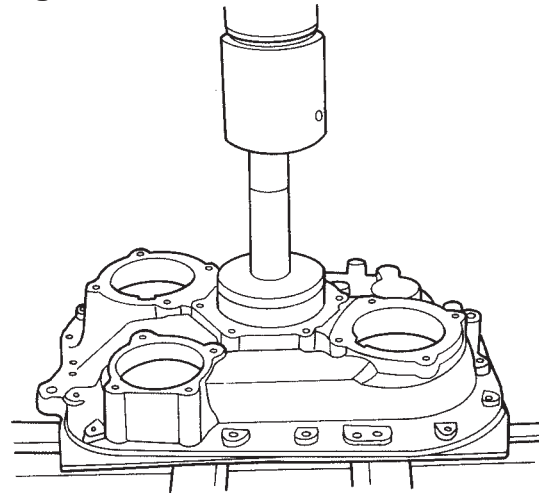

- 8. If removed, install the bearing cones on the auxiliary countershafts. See the following procedure. **Figure 16-29.**

CAUTION

A bearing heater can be used to install the bearing cone. Follow the instructions of the manufacturer of the bearing heater. The heated cones can burn you.

- a. Put the countershaft in a press so that the front of the countershaft is toward the top of the press. Support the countershaft on the gear.
- b. Put the front cone on the countershaft so that the bottom of the cone is toward the gear.
- c. Put a sleeve on the inner race of the cone. Press the cone on the countershaft. The cone is correctly installed when the bottom of the cone touches the gear.
- d. Turn the shaft over so that the opposite end is toward the top of the press. Repeat steps a-c to install the rear cone.

Figure 16-29

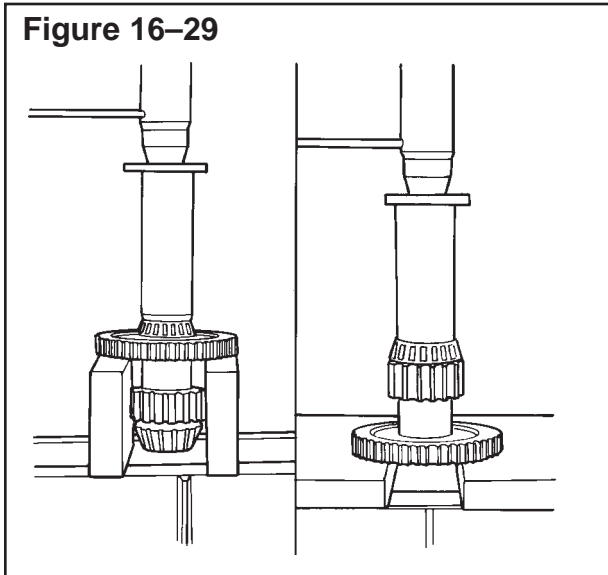

9. Install the auxiliary cover on the output shaft and low gear assembly and the auxiliary countershafts. See the following procedure.
- a. Put the output shaft and low gear assembly in a press. Make sure the threads on the shaft are toward the top of the press. **Figure 16-30.**
 - b. Put each auxiliary countershaft next to the output shaft. Make sure the timing marks on each countershaft and the low gear are aligned. **Figure 16-30.**

Figure 16-30

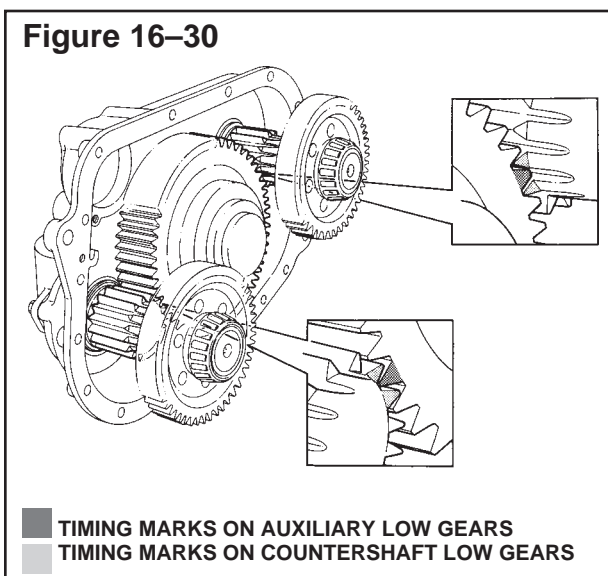

- c. Put the auxiliary cover on the output shaft and low gear assembly and the auxiliary countershafts. **Figure 16-31.**

Figure 16-31

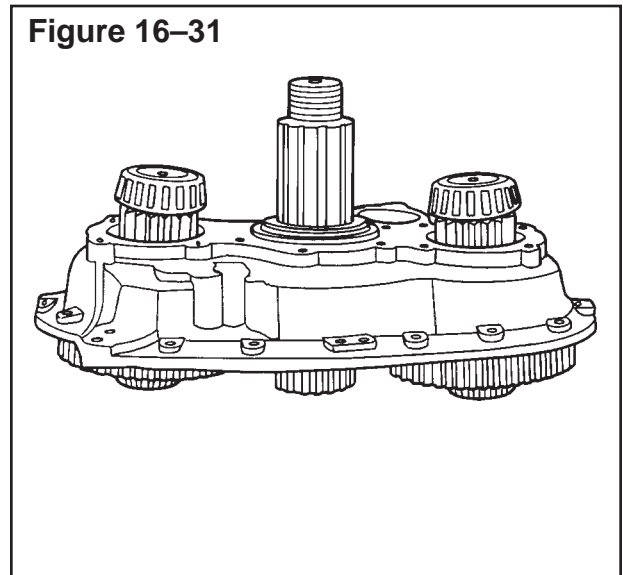

- d. Install the outer bearing cone on the output shaft. Make sure the letters on the cone are toward the top of the press.
- e. Install a sleeve on the outer bearing cone. Press the cone on the shaft and into the cup in the bore of the cover. **Figure 16-32.**

Figure 16-32

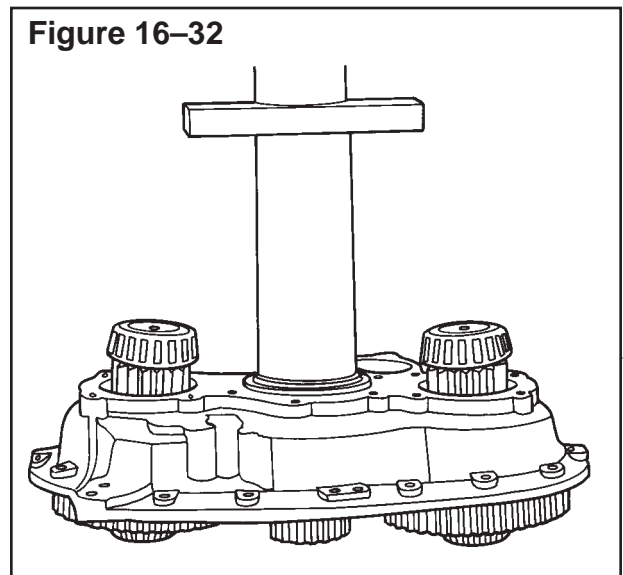

Section 16 Overhauling the Auxiliary Case

Nine-Speed and Ten-Speed Transmissions

10. Assemble the synchronizer assembly.

- a. Put the low synchronizer on the table so that the pins are toward you.
- b. Install the synchronizer collar over the pins on the low synchronizer. Make sure the chamfered holes in the collar are over the pins and towards the low synchronizer. Make sure the low synchronizer touches the collar. **Figure 16-33.**

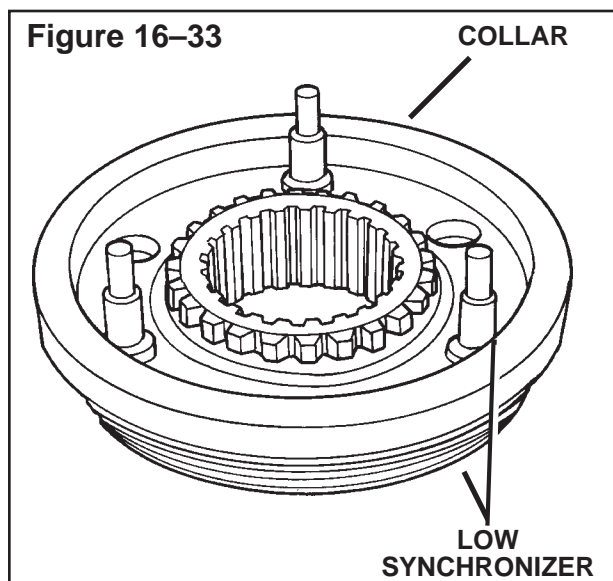

- c. Install the springs into the holes in the high synchronizer. Use grease to retain the springs. Use a multi-purpose lubricating grease with NLGI Number 2 rating. **Figure 16-34.**
- d. Install the high synchronizer on the pins of the low synchronizer cone. Rotate the high synchronizer so that the springs are against the side of the pins of the low synchronizer. **Figure 16-34.**

Figure 16-34

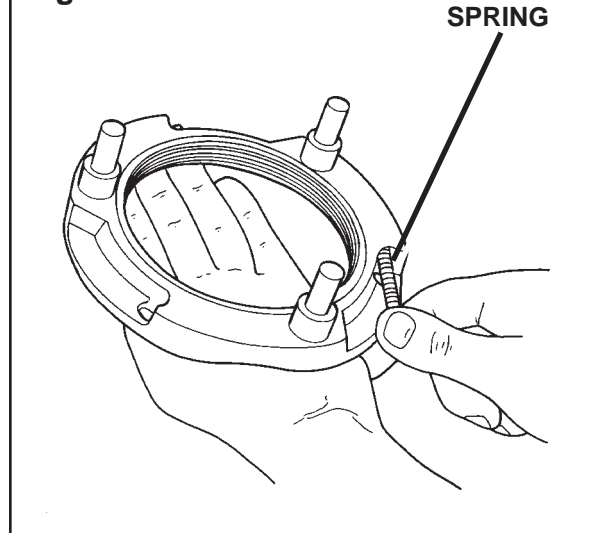

NOTE:

Put a towel under the low synchronizer to keep the assembly from moving when the high synchronizer is installed.

- e. Push down on the high synchronizer so that the pins of the low synchronizer are installed in the holes in the high synchronizer. **Figure 16-35.**

Figure 16-35

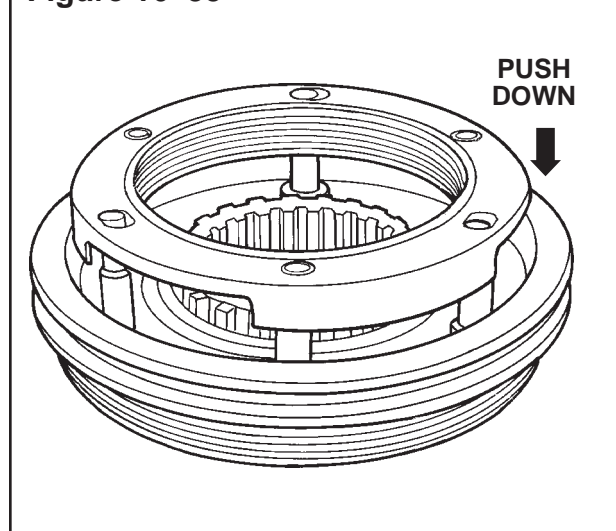

11. Support the output shaft so that the cover is in the upright position.
12. Make sure the timing marks on the low gear and each auxiliary countershaft are in alignment.
13. Install the synchronizer assembly on the output shaft inside the auxiliary cover. Make sure the high synchronizer is toward you. **Figure 16-36.**

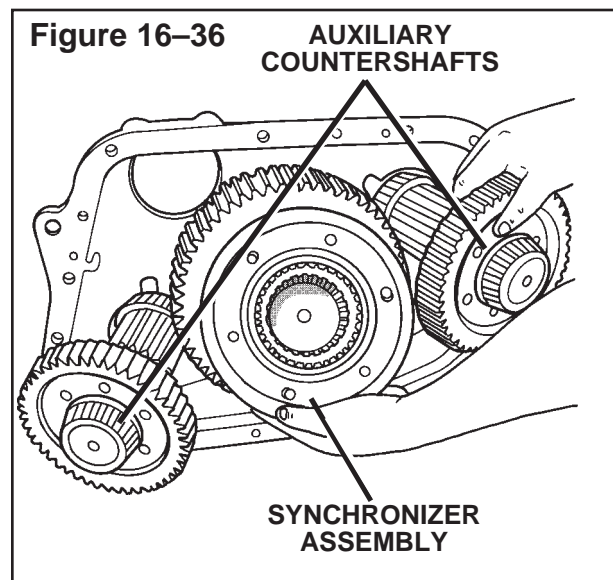

NOTE:

The cup was marked during disassembly. Make sure the cup is installed in the correct location.

14. Install the correct cup on the rear bearing of the upper auxiliary countershaft. **Figure 16-37.**
15. Install the correct cup on the rear bearing of lower auxiliary countershaft. **Figure 16-37.**

Figure 16-37

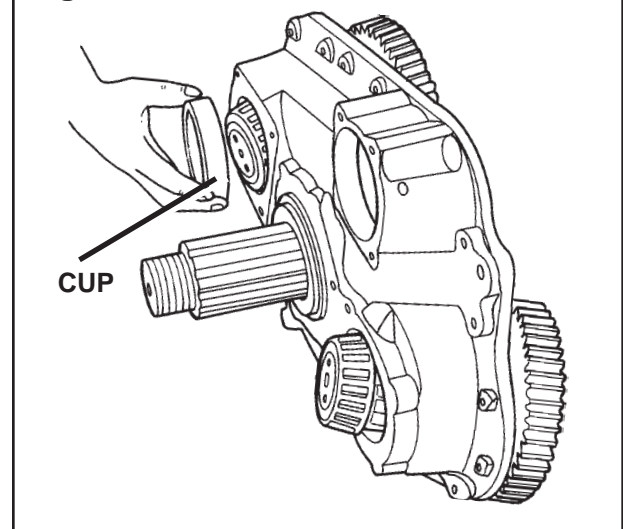

16. ***On Design Level 1 Nine-Speed Transmissions***, do the following:

- a. Install the snap ring that retains the cups in the case. Use the snap ring that was removed during disassembly.
- b. install Holding Cover Tools, 3305-R-1214 on each countershaft. Use capscrews to fasten the cover tools to the countershafts and the cover. **Figure 16-38.**

On Design Level 2 Nine-Speed and Ten-Speed Transmissions, do the following:

- a. Install the selective washers in front of the cups. Make sure the tabs on the washers are in the slots in the case. **Figure 16-38.**
- b. Install Holding Cover Tools, 3305-R-1214 on each countershaft. Use capscrews to fasten the cover tools to the countershafts and the cover. **Figure 16-38.**

Section 16 Overhauling the Auxiliary Case

Nine-Speed and Ten-Speed Transmissions

Figure 16-38

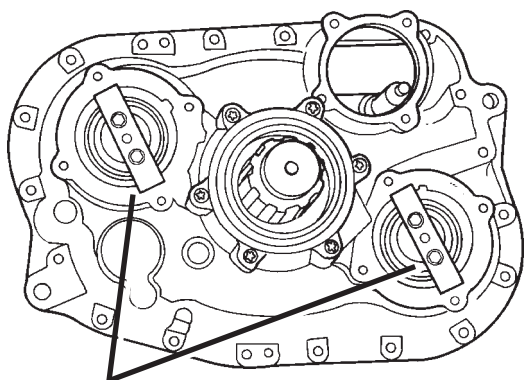

HOLDING
COVER TOOLS
3305-R-1214

17. If removed, use the correct driver tool to install a new bushing for the speedometer gear inside the output bearing retainer.
18. Use a sealant dispenser and Loctite® RTV Sealant™, #5699 (Meritor Part Number 2297-A-7021) or equivalent to make a 1/8 inch (2 mm) sealant pattern for the output bearing retainer. Make sure the sealant material does not cover the oil passage. See **Figure 16-39** for the sealant pattern. See "Installing the Sealant" in Section 1.

Figure 16-39

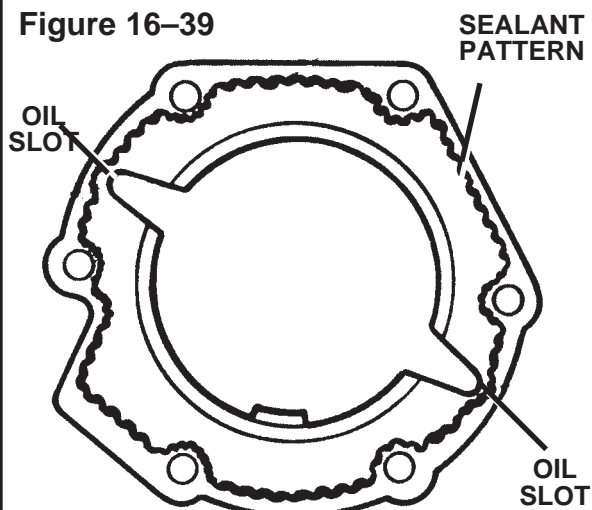

19. Install the output bearing retainer on the auxiliary cover. Make sure the oil passage in the retainer is aligned over the oil hole in the cover.

Figure 16-40.

Figure 16-40

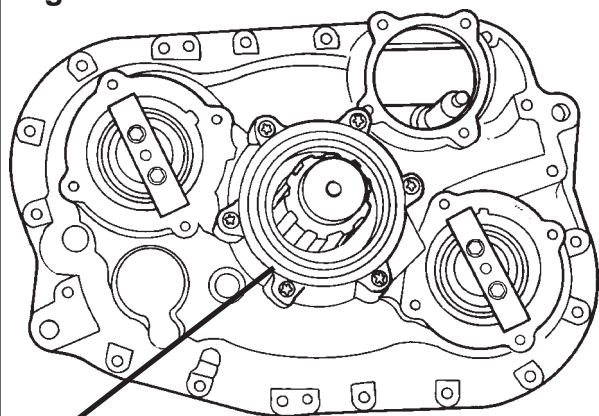

OUTPUT
BEARING
RETAINER

20. Install the mounting capscrews for the output bearing retainer. Tighten the capscrews to 35-45 lb-ft (47-71 N.m).



21. If removed, install the oil seal in the output bearing retainer. See the following procedure. **Figure 16-41.**

CAUTION

Hold the seal only on the outer diameter. Do not touch the inner diameter of the seal. Touching contaminates the inner diameter of the seal and causes a leak between the shaft and the seal.

- a. Lubricate the outer diameter of the seal. Put the oil seal in the cover. Make sure the letters on the seal are installed away from the retainer.

CAUTION

Use the correct tool to install the oil seal. If the correct tool is not used, the seal will leak.

- b. Use seal driver tool, 3256-Z-1014, (Kent-Moore Tool Number J-39161) to drive the seal into the cover. The seal is correctly installed when the outer flange of the seal touches the retainer.

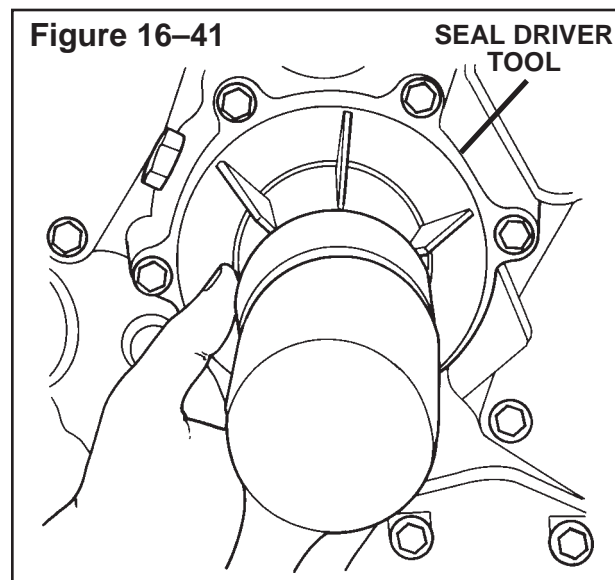

22. Put the **HI-LO** shift fork in position so that the fork engage the synchronizer collar. Make sure the bore of the fork is aligned with the bore of the range cylinder. Make sure the hole in the fork is installed away from the cover. **Figure 16-42.**
23. Install the **HI-LO** shift shaft from inside the front of the auxiliary cover. Make sure the threads on the end of the shaft are installed first. **Figure 16-42.**

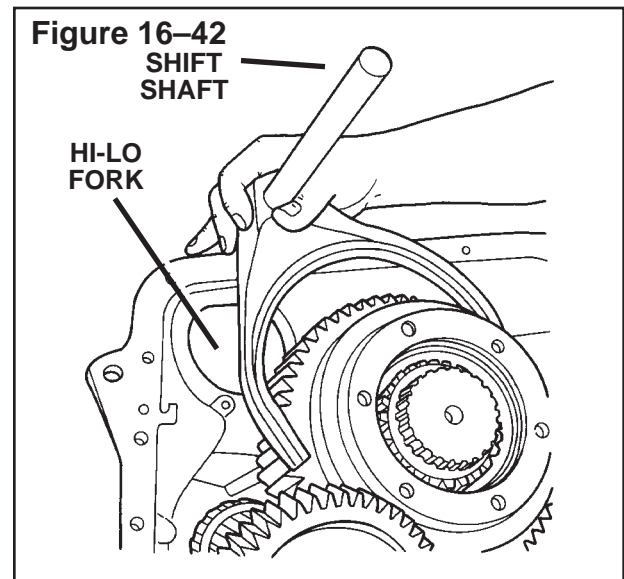

NOTE:

If a pin and a clip was used to fasten the HI-LO fork to the shaft, replace the pin and the clip with a nut (NL-25-1) and shoulder bolt (10-X-1534).

24. Align the hole of the shaft with the hole of the shift fork. Install the bolt and the lock nut. Tighten the nut to 8-12 lb-ft (11-16 N.m). **Figure 16-43.**

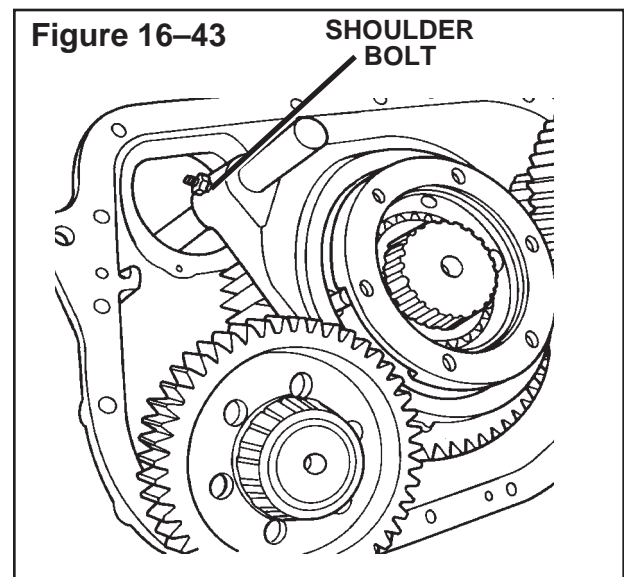

⚠ CAUTION

Do not use too much silicone lubricant on the O-rings and the bore of the range cylinder housing. If too much lubricant is used, the range may shift slowly.

25. Lubricate the O-rings and the bore of the range cylinder housing with the a silicone lubricant such as Dow Corning #111 Silicone Grease or equivalent. Install the O-ring in the groove in the bore of the range cylinder housing. **Figure 16-44.**

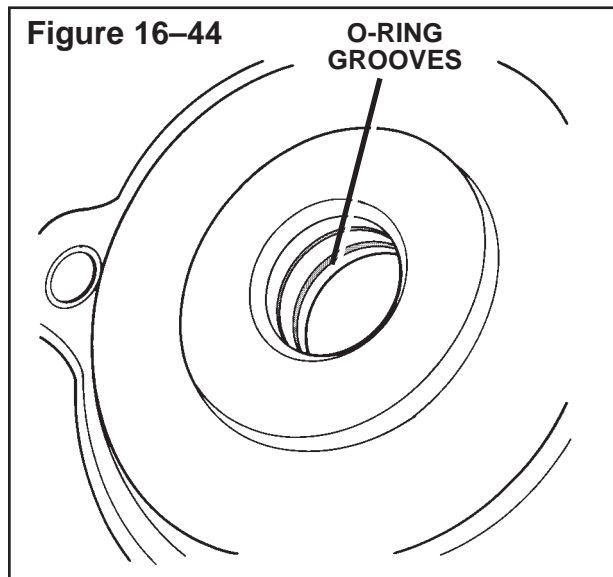

26. Use a sealant dispenser and Loctite® RTV Sealant™, #5699 (Meritor Part Number 2297-A-7021) or equivalent to make a 1/8 inch (2 mm) sealant pattern for the range cylinder housing. See **Figure 16-45** for the sealant pattern. See “Installing the Sealant” in Section 1. Install the range cylinder housing on the auxiliary cover.

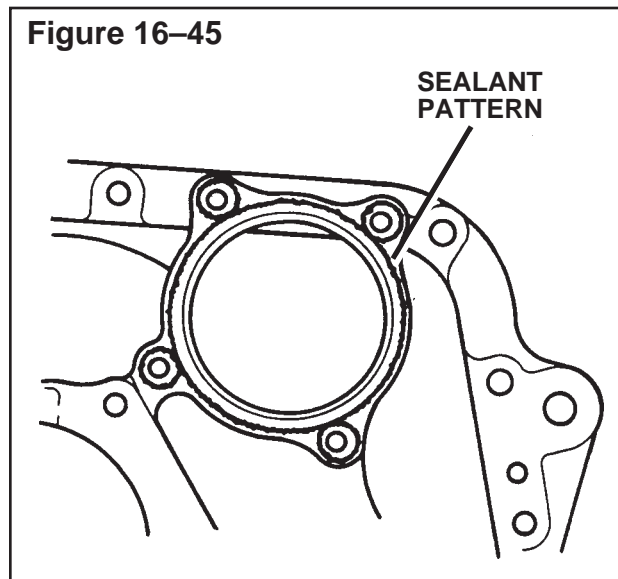

27. Lubricate the O-rings for the piston with a silicone lubricant such as Dow Corning #111 Silicone Grease or equivalent. Install the O-rings on the outer diameter and the inner diameter of the piston. **Figure 16-46.**

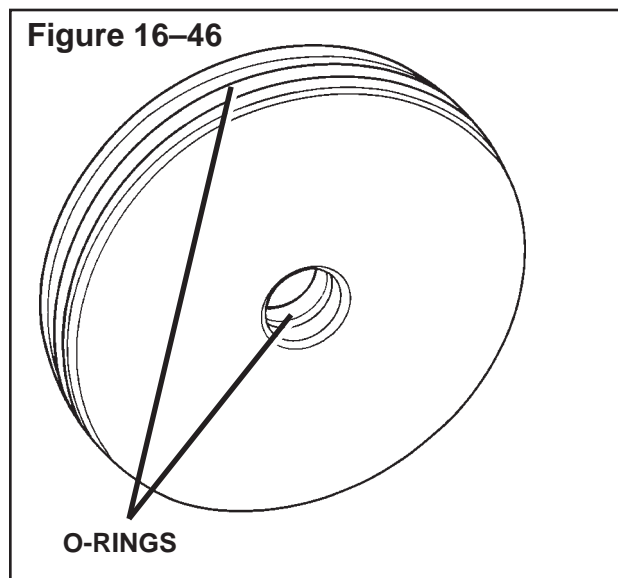

28. Install the piston on the shaft in the range cylinder. Install the nut that fastens the piston on the shaft. Tighten the nut to 35-50 lb-ft (48-67 N.m). **Figure 16-47.** **T**
29. Install the gasket between the range cylinder cover and the range cylinder housing. Install the cover.
30. Install the capscrews and the washers that fasten the range cylinder cover to the auxiliary cover. Tighten the capscrews to 35-45 lb-ft (47-61 N.m). **T**
31. Put the auxiliary cover in the **LO** range.
32. Clean the outer diameter of the cups for the front bearing cones of the auxiliary countershafts. Put the cups in the correct bores in the transmission case. **Figure 16-48.**

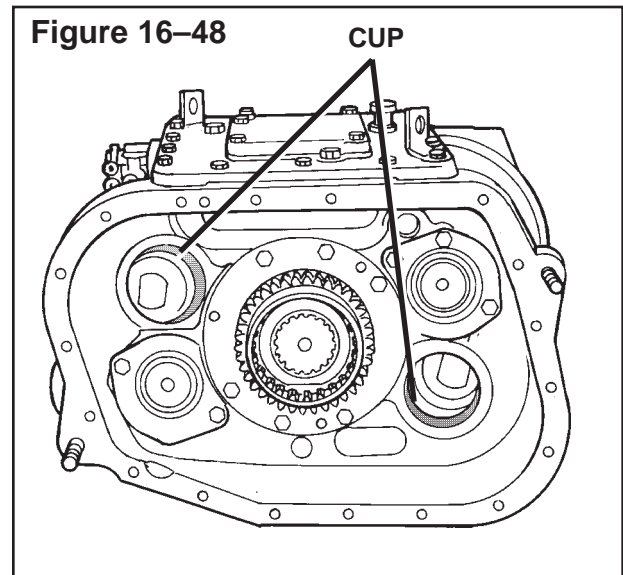
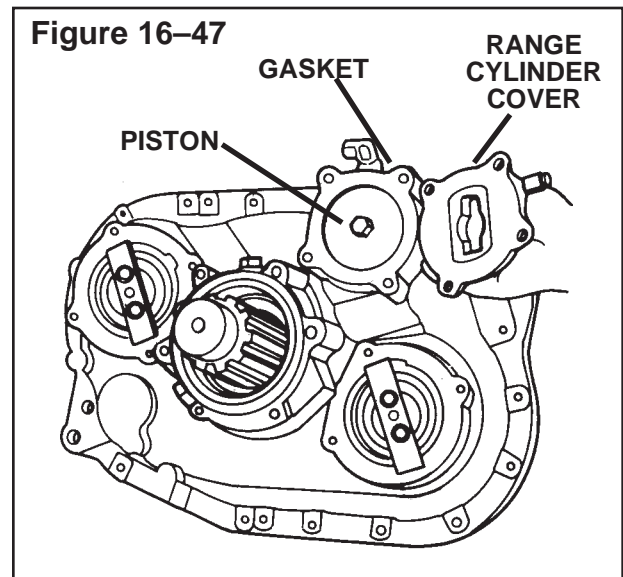

Disassembling the Auxiliary Case — Thirteen-Speed Transmissions

See Figure 16-49.

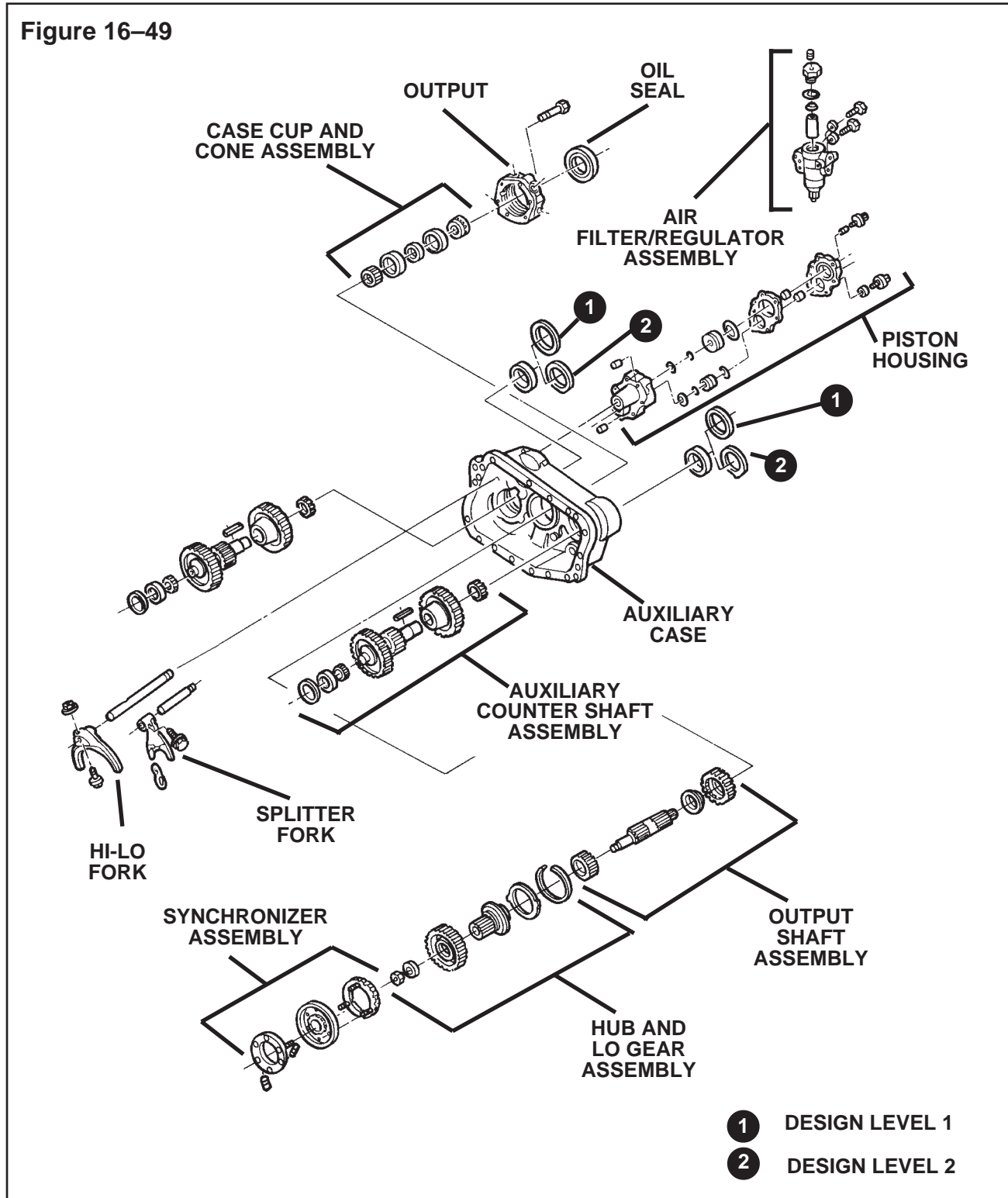

WARNING

To prevent serious eye injury, always wear safe eye protection when doing maintenance or service.

1. Put the auxiliary cover in a holding fixture, such as an axle repair stand.
2. Remove the capscrews and washers that fasten the piston housing cover to the auxiliary cover. Remove the cover and the gasket. If necessary, remove the fitting and the shuttle valve from the cover. **Figure 16-50.**
3. Remove the nuts and the washers that fasten the pistons to the shift shafts. Discard the nut. **Figure 16-50.**

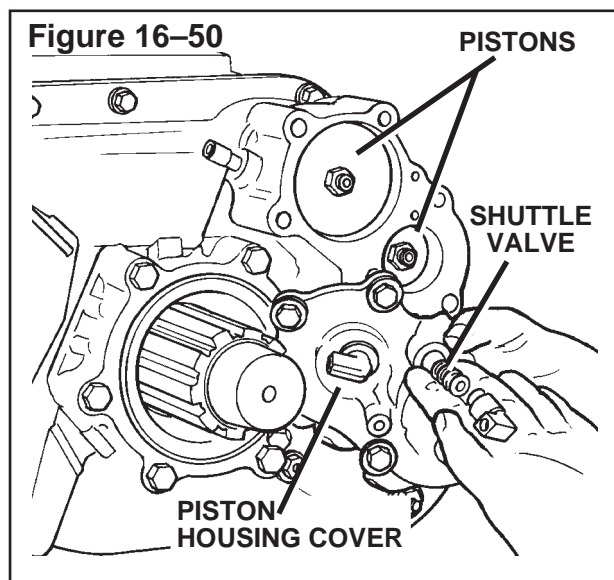

4. Remove the piston housing and the pistons as an assembly. Inspect the O-rings on the pistons. Replace worn or damaged O-rings. **Figure 16-51.**

Figure 16-51

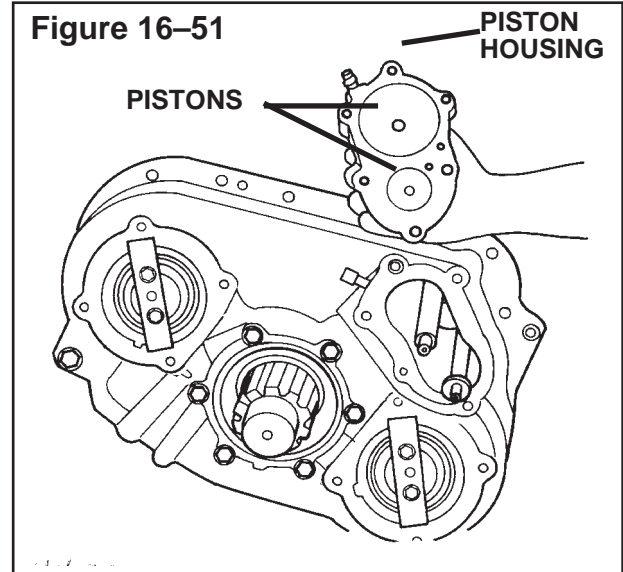

5. Use a scraper to remove the gasket material from between the cover and the housing.
6. Inspect the O-rings in the shaft bores of the piston housing. If worn or damaged, replace the O-rings. **Figure 16-52.**

Figure 16-52

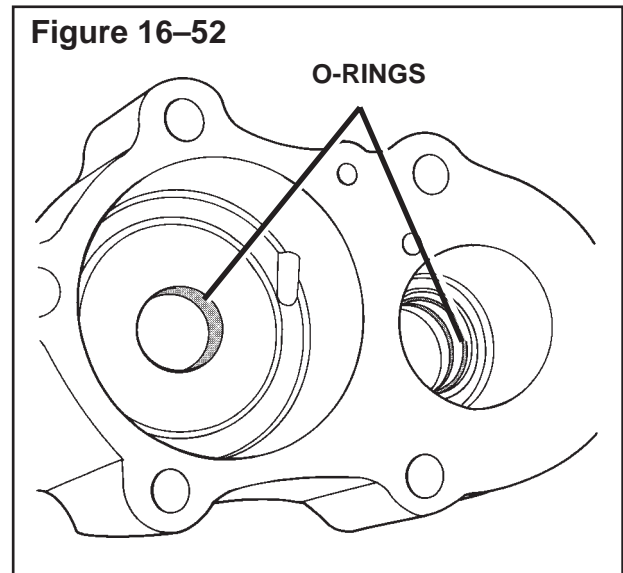

7. Remove the mounting capscrews and washers from the output bearing retainer. Remove the retainer. Use a scraper to remove the gasket material. Remove the speedometer gear from the shaft.
8. Inspect the oil seal in the output bearing retainer. If the seal is worn or damaged, remove and replace the seal. **Figure 15-53.**
9. If a mechanical speedometer is used, inspect the speedometer bushing inside the output bearing retainer. If worn or damaged, remove the bushing. **Figure 16-53.**

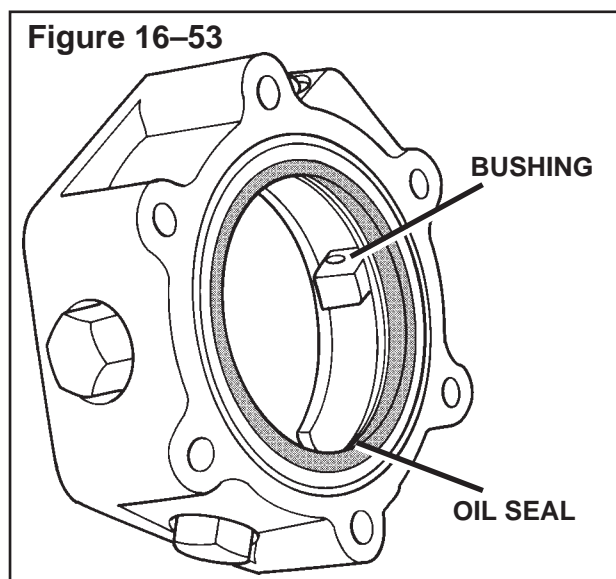

10. Move the assembly in the repair stand so that the inside of the cover is toward you.

NOTE:

If a pin and a clip is used to fasten the HI-LO fork to the shift shaft, replace with a nut and shoulder bolt during assembly.

11. Remove the shoulder bolt and the nut (or pin and clip) that fastens the HI-LO fork to the shift shaft. **Figure 16-54.**

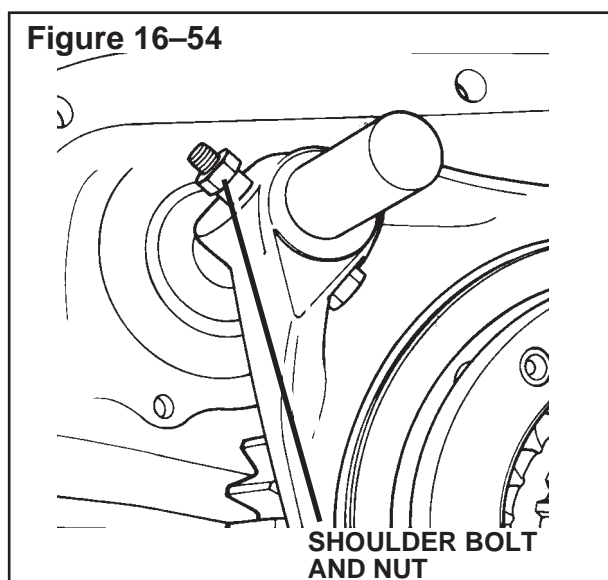

WARNING

When using a hammer and a steel drift, wear safe eye protection and make sure the tools are in safe condition. Do not use tools that are worn or damaged ("mushroomed"). If the tools are not in safe condition, pieces can break and cause serious personal injury.

12. If necessary, use a hammer and a brass drift to remove the shift shaft from the HI-LO fork. **Figure 16-55.**
13. Remove the HI-LO fork from the synchronizer collar. **Figure 16-55.**

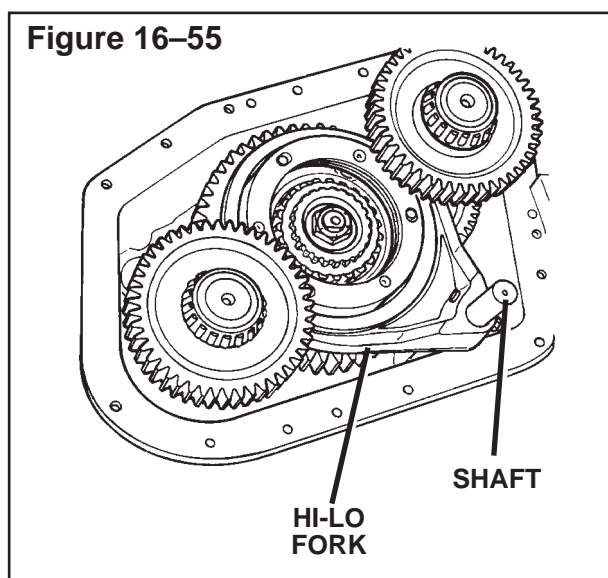

NOTE

Install a capscrew to fasten the plate to the cover to keep the gears from moving when the nut is removed. Figure 57.

14. Remove and discard the nut and washer that fasten the **LO** gear and synchronizer assembly to the output shaft. **Figure 16-56.**

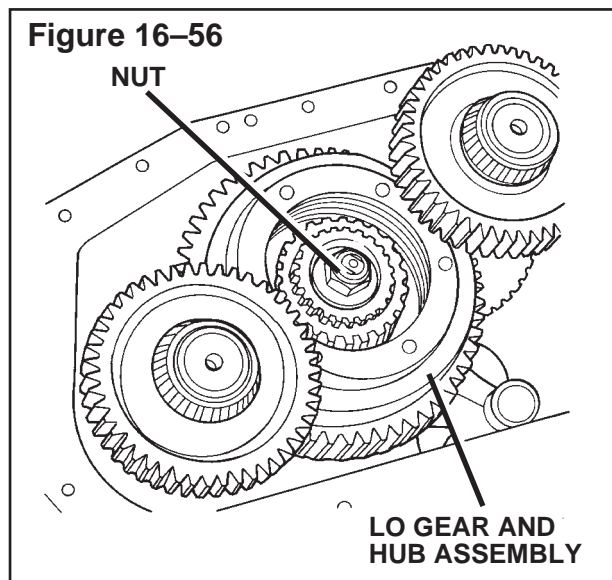

15. Remove the capscrews and washers that fasten the holding plates on the countershafts and cover. **DO NOT CHANGE THE POSITION OF THE AUXILIARY COVER IN THE REPAIR STAND.** Remove the holding plates. **Figure 16-57.**
16. **On Design Level 1 Transmissions,** Remove the snap rings that fastens the upper and lower auxiliary countershafts in the cover. Remove the rear bearing cups. **DO NOT CHANGE THE POSITION OF THE COVER IN THE REPAIR STAND.** Mark the snap rings and cups for correct installation. **Figure 16-58.**

Figure 16-57

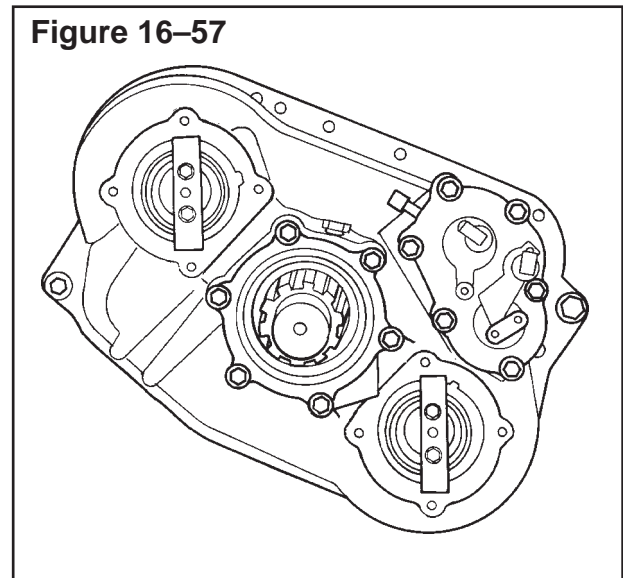
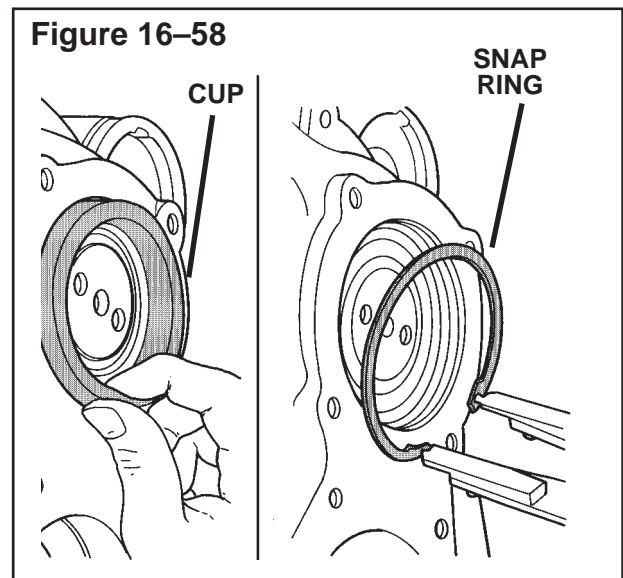
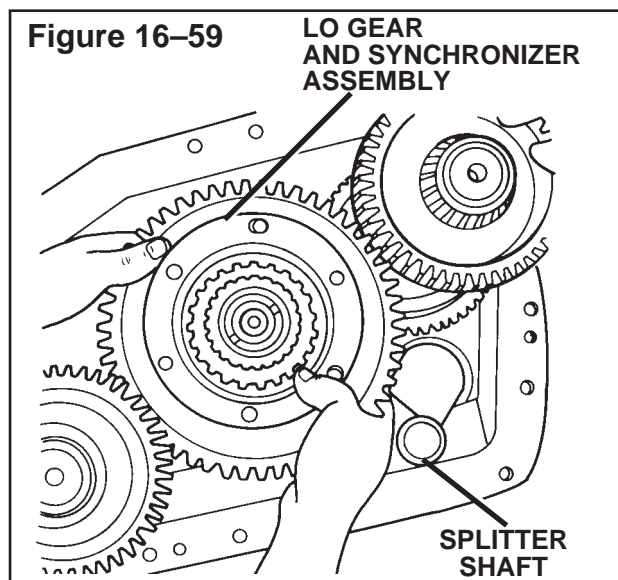

Figure 16-58



17. Remove the **LO** gear and synchronizer assembly. See the following procedure. **Figure 16-59.**
 - a. Move the splitter shaft so that the splitter fork will not touch the **LO** gear during removal.
 - b. Move each countershaft away from the **LO** gear.
 - c. Lift the **LO** gear and coupling assembly out of the cover.



d. Remove the splitter fork and shaft assembly and the clutch collar as an assembly **Figure 16-60**.

18. Remove the upper and lower auxiliary countershafts from the cover. **Figure 16-60**.

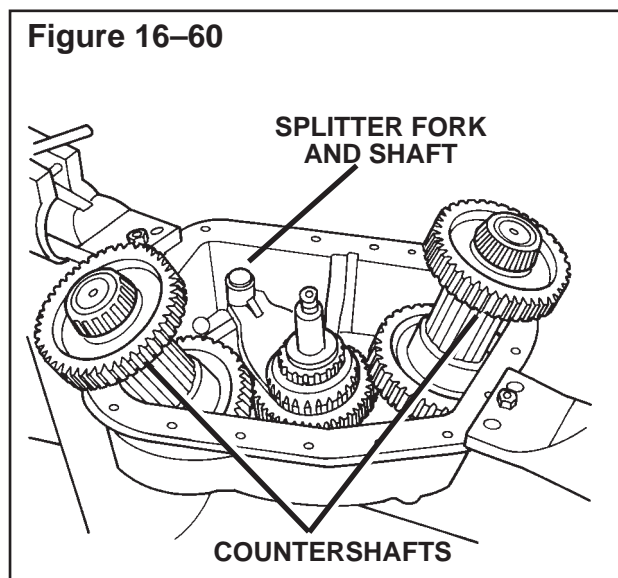

19. If worn or damaged, disassemble the **LO** gear and synchronizer assembly. See the following procedure.

a. Remove the low synchronizer assembly from the **LO** gear assembly. **Figure 16-61**.

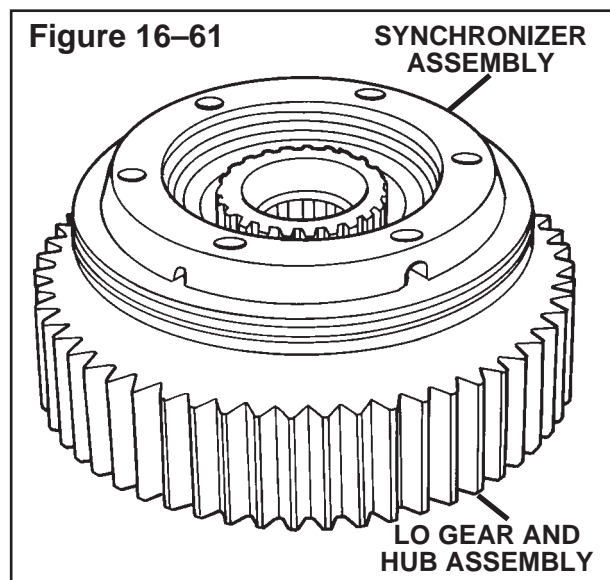

NOTE:
When separating the synchronizers, put a towel over the synchronizers to keep the springs from flying out.

b. Pull up on the high synchronizer to separate the high synchronizer from the low synchronizer. Do not lose the springs when the synchronizers are separated.

Figure 16-62.

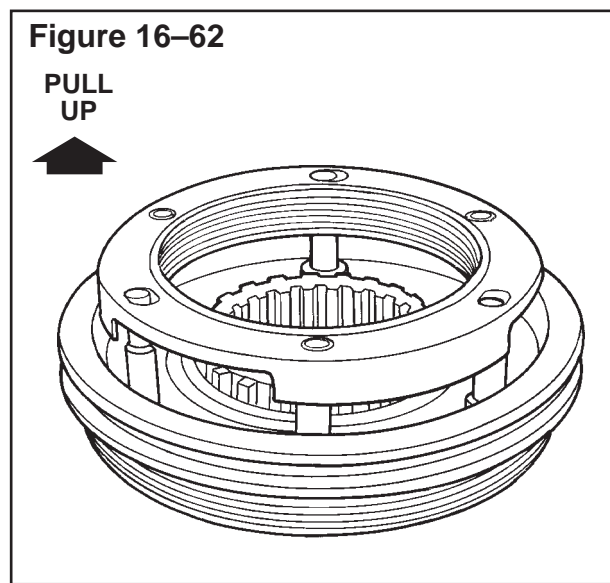

- c. Remove the springs from the holes in the high synchronizer.
Figure 16-63.

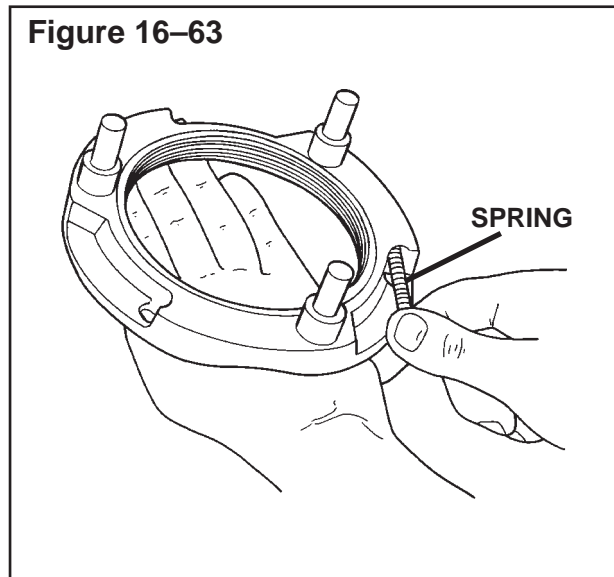

- d. Remove the collar from the low synchronizer. **Figure 16-64.**

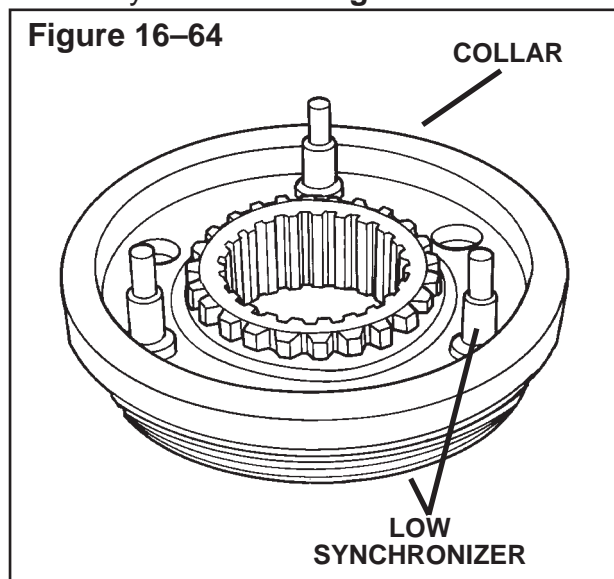

- e. Remove the snap ring and washer that fastens the **LO** gear on the coupling. Remove the thrust washer and the coupling. **Figure 16-65.**

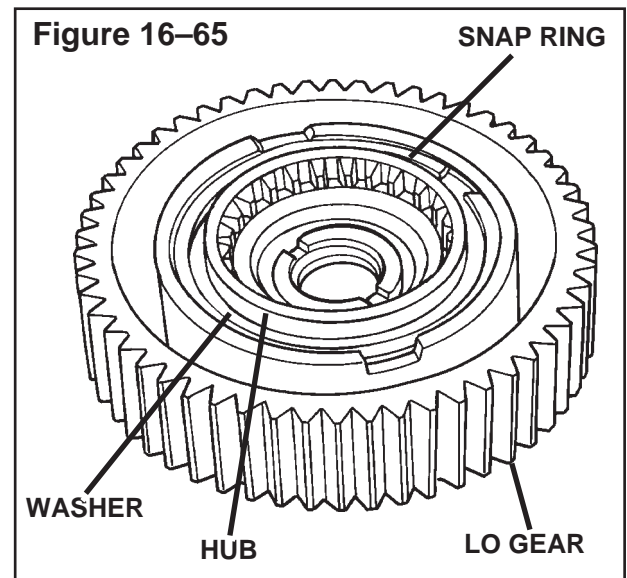

20. If necessary, disassemble the splitter fork and shaft assembly.

Figure 16-66.

- a. Cut and discard the lock wire on the cap screw. Remove the cap screw.
- b. Remove the splitter fork from the shaft.

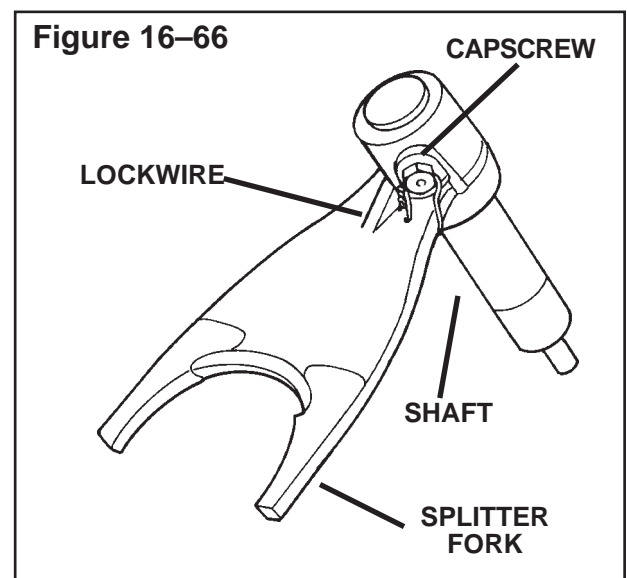

Section 16 Overhauling the Auxiliary Case

13-Speed Transmission

21. If worn or damaged, remove the front and rear bearing cones and the splitter gear from the upper and lower auxiliary countershafts.

Use a puller to remove the front cone. Make sure the jaws of the puller are under the bearing races.

Figure 16-67.

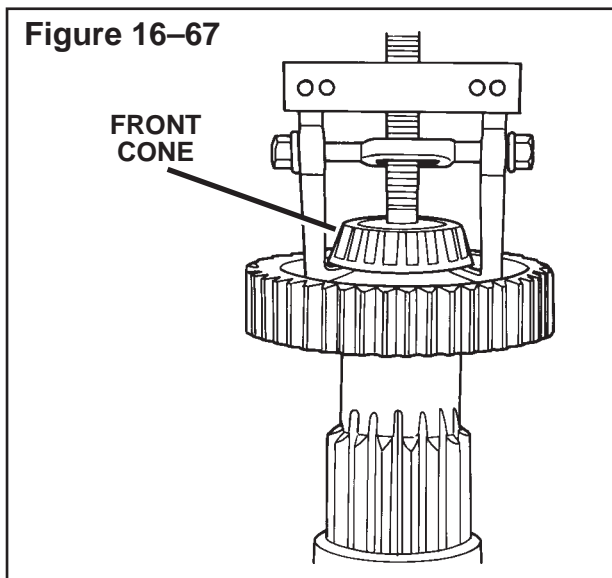

Remove the rear cone and splitter gear as an assembly. Support the splitter gear in a press so that the rear cone is toward the top of the press. Put a sleeve on the countershaft. Press the countershaft from the cone and gear. Remove the key from the countershaft. **Figure 16-68.**

22. If necessary, remove the output shaft and the OD gear assembly from the

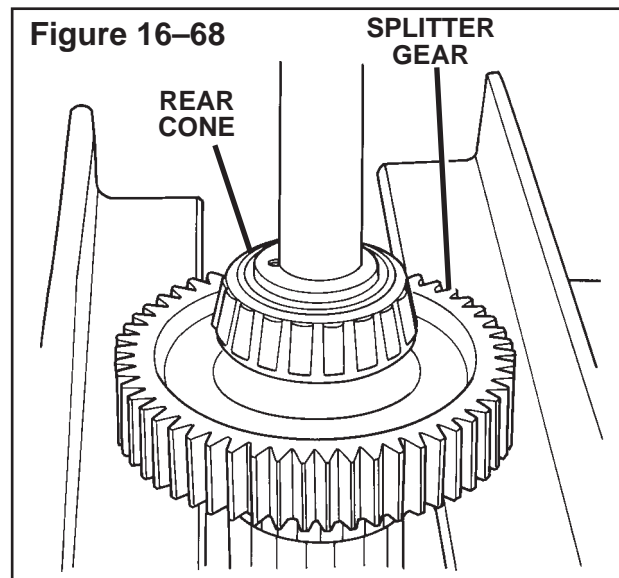

auxiliary cover. See the following procedure. **Figure 16-69.**

- Support the auxiliary cover in a press. Make sure the output shaft is toward the top of the press.
- Put a sleeve on the top of the output shaft. Press the output shaft and OD gear assembly from the cover.
- Remove the outer bearing cone from the cover.
- Remove the cover from the press.

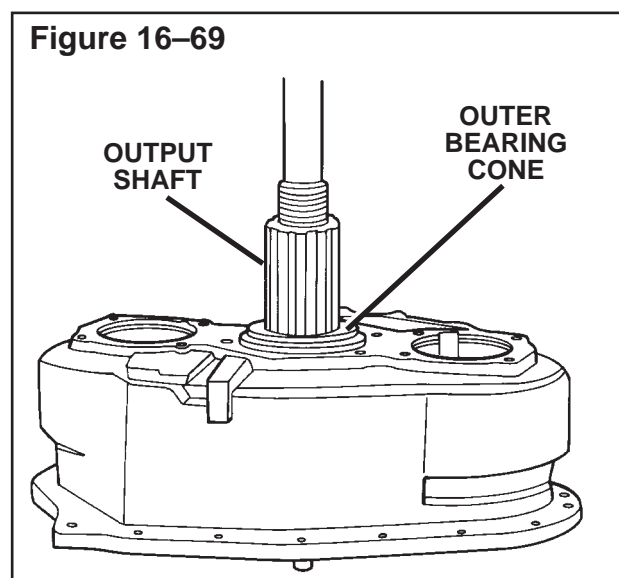

23. If necessary, remove the inner and the outer bearing cups for the output shaft from the auxiliary cover. See the following procedure. **Figure 16-70.**
- Support the case on a press. Make sure the inner surface of the case is toward the top of the press.
 - Put a sleeve on the outer race of the outer bearing cup.
 - Press the inner and the outer cups from the cover. Discard the cups.

Figure 16-70

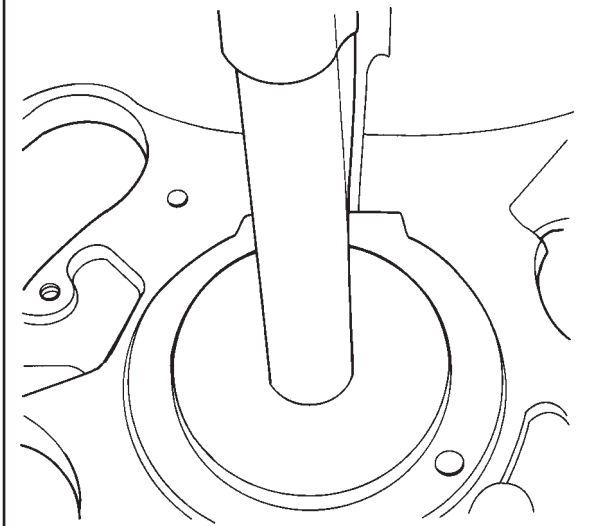

24. If worn or damaged, remove the inner bearing cone from the output shaft and **OD** gear assembly. See the following.
- Remove the spacer from the shaft. **Figure 16-71.**
 - Support the assembly in the press by the gear. Make sure the threads are toward the top of the press.
 - Put a sleeve on top of the output shaft. Press the shaft out of the cone and gear. Discard the cone. **Figure 16-72.**
25. Remove the spacer from the output shaft. **Figure 16-73.**
26. Inspect all parts. See "Inspecting the Parts" in Section 1.

Figure 16-71

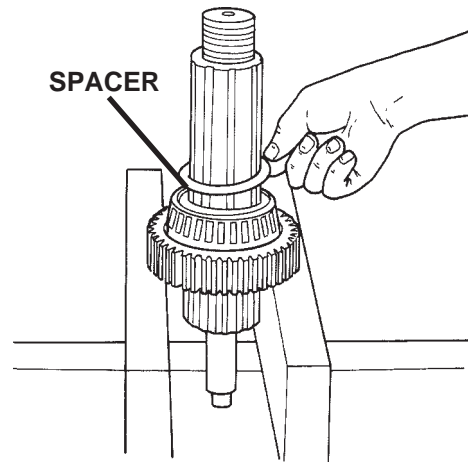

Figure 16-72

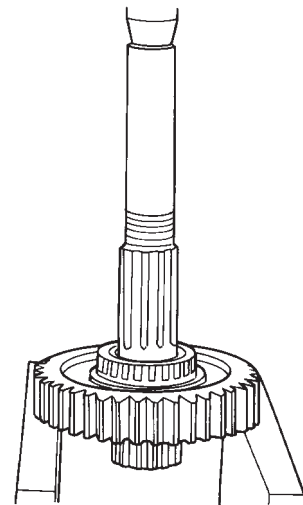
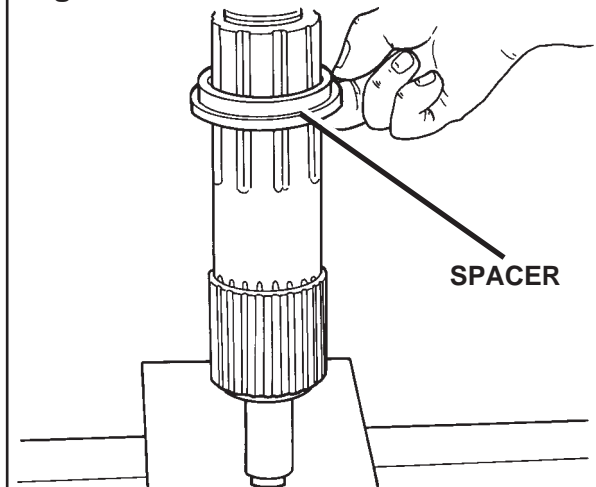

Figure 16-73



Assembling the Auxiliary Case—Thirteen-Speed Transmissions

See Figure 16-49.

1. Lubricate all the parts of the auxiliary cover with new oil used in the transmission
2. Put timing marks on the **OD** gear. Mark one tooth with paint. Mark a second tooth opposite (180°) the first timing mark. **Figure 16-74.**

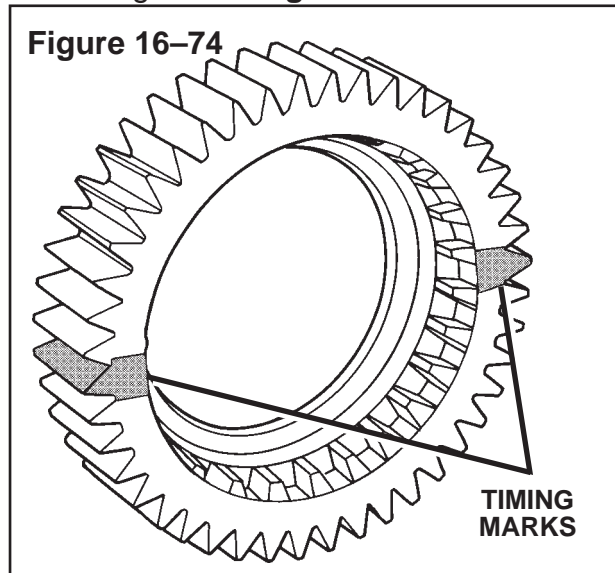

3. Put the output shaft on the work bench. Make sure the splined end of the shaft is up.
4. Install the spacer on the output shaft. Make sure the small shoulder of the spacer is toward the splined end of the shaft for the output yoke. **Figure 16-75.**

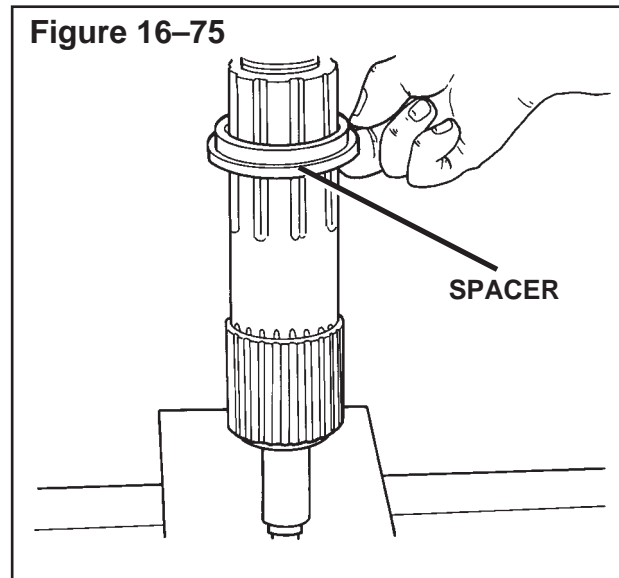

5. Install the auxiliary **OD** gear on the output shaft. **Figure 16-76.**

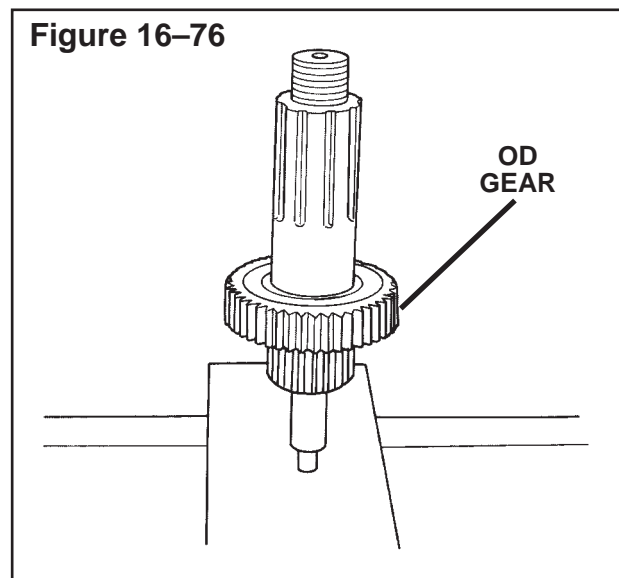

6. Install the bearing cone on the output shaft and **OD** gear assembly. See the following procedure. **Figure 16-77.**
 - a. Put the output shaft and **OD** gear assembly on a press. Support the shaft on the bottom of the shaft. Make sure the large threads on the shaft are toward the top of the press.

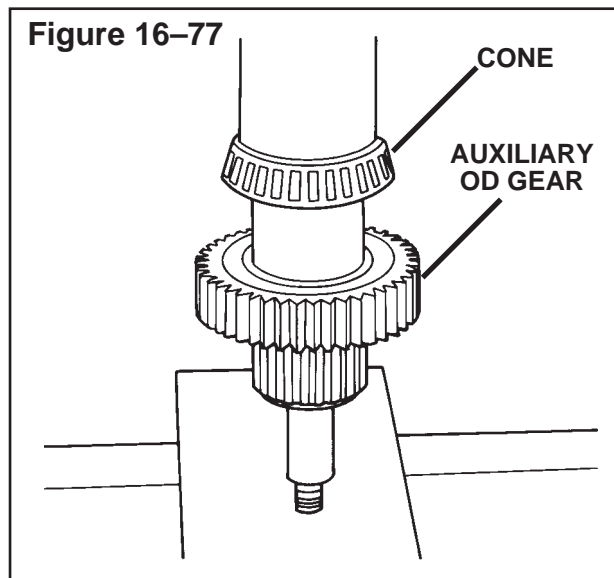

- b. Install a bearing cone on the shaft. Make sure the letters on the cone assembly are toward the gear.
- c. Put a sleeve on the cone. Press the cone on the shaft until the cone touches the gear. Make sure the gear and the bearing cone rotates on the shaft.
- d. Install the spacer on the shaft. **Figure 16-78.**

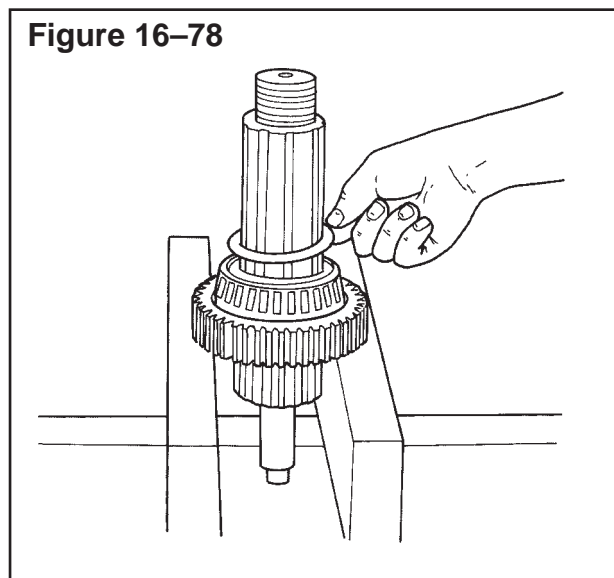

7. If removed, install the bearing cups for the output shaft in the auxiliary cover. See the following procedure.
 - a. Put the auxiliary cover in a press so that the outside of the cover is toward the top of the press.
 - b. Put the inner bearing cup in the cover. Make sure the letters on the cup are toward you. Install a sleeve or a bearing installation tool on the race of the bearing.
 - c. Press the inner cup into the cover until the top of the cup is $\frac{3}{8}$ inch below the outer surface of the cover. **Figure 16-79.**

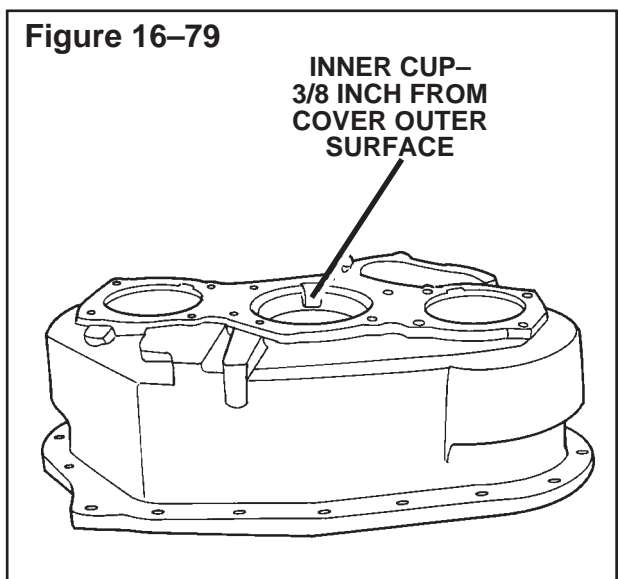

- d. Put the outer cup on top of the inner cup. Make sure the letters on the cup are toward you. **Figure 16-80.**
- e. Put a sleeve or installation tool on the top of the outer cup. Press both cups into the bore. The cups are correctly installed when the flange on the outer cup touches the shoulder in the bore of the cover. **Figure 16-80.**

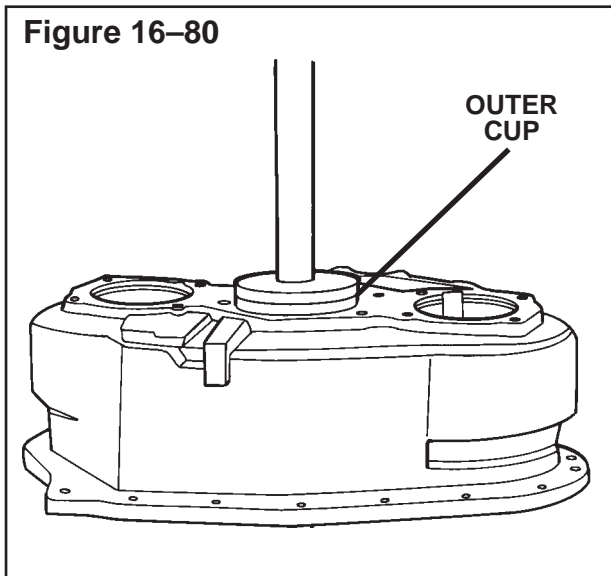

8. Install the auxiliary cover on the output shaft and **OD** gear assembly. See the following procedure. **Figure 16-81.**
 - a. Put the output shaft and **OD** gear assembly in a press. Put a support under the gear. Make sure the large threads on the shaft are toward the top of the press.
 - b. Put the auxiliary cover on the output shaft assembly. Rotate the cover to make sure the output shaft inner bearing cone is installed in the cup.
 - c. Install the spacer on the top of the inner bearing cone of the output shaft.
 - d. Install the outer bearing cone on the output shaft. Make sure the letters on the cone are toward the top of the press.
 - e. Install a sleeve on the outer bearing cone. Press the cone on the shaft and into the cup in the bore of the cover.

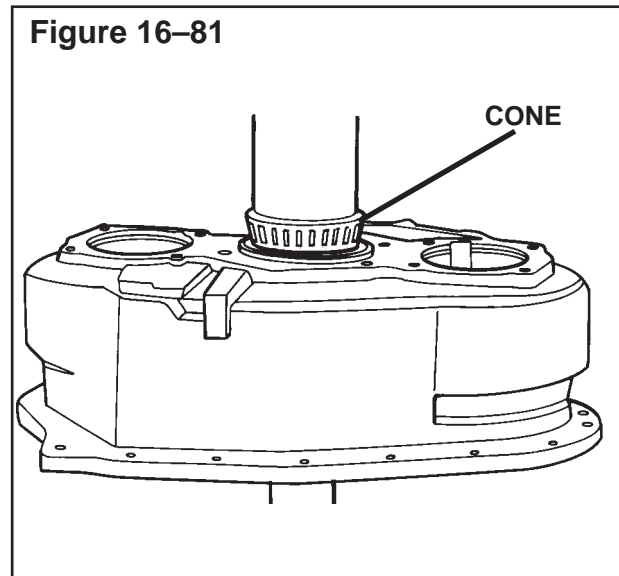

9. Put the gear and cover assembly on a bench. Make sure the inside of the cover is toward you.
10. Use paint to put timing marks on two teeth of each countershaft **OD** gear. Make sure the mark is aligned with the dot on the counter shaft.
Figure 16-82.

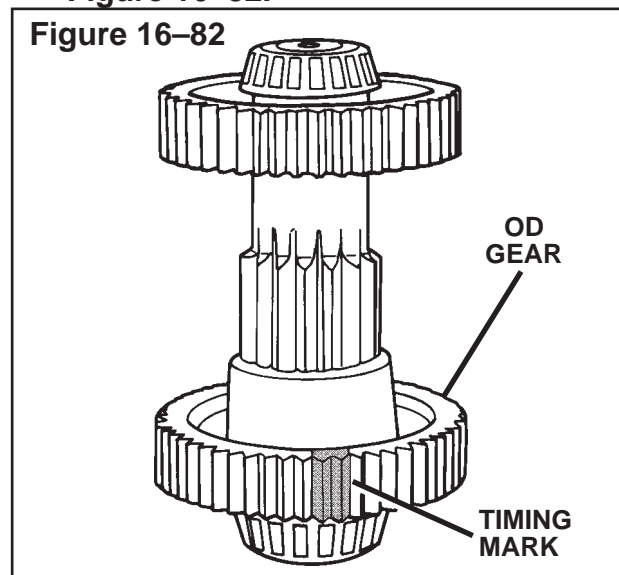

11. If necessary, assemble the splitter fork and shaft assembly. **Figure 16-83.**
 - a. Install the shaft in the fork. Make sure the holes in the shaft and the fork are aligned.

- b. Install the capscrew. Tighten to 35-45 lb-ft (47-61 N.m).
- c. Install a new lock wire in the cap-screw and fork.

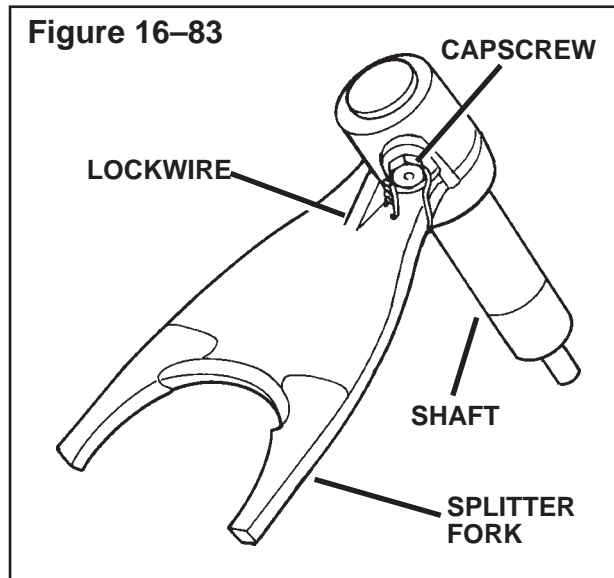

12. Assemble the **LO** gear and synchronizer assembly.
- a. Install the snap ring in the groove inside the **LO** gear and hub assembly. Make sure the round side of the snap ring is installed away from the gear. Install the washer inside the gear. **Figure 16-84.**

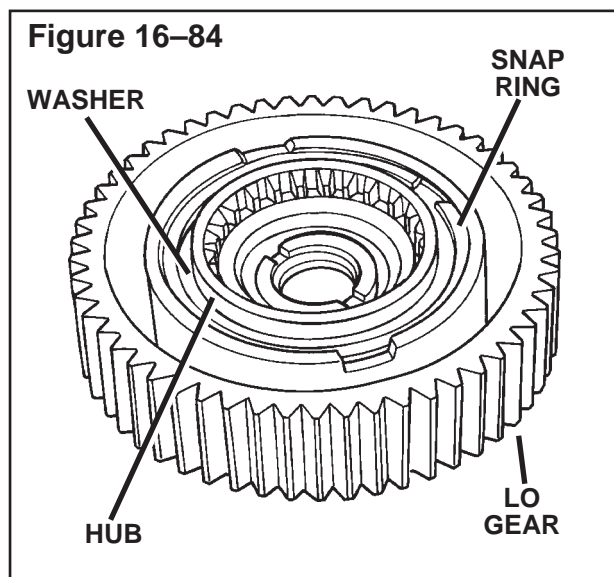

- b. Put the low synchronizer on the table so that the pins are toward you.
- c. Install the synchronizer collar over the pins on the low synchronizer cone. Make sure the chamfered holes in the collar are over the pins. Make sure the cone touches the collar. **Figure 16-85.**

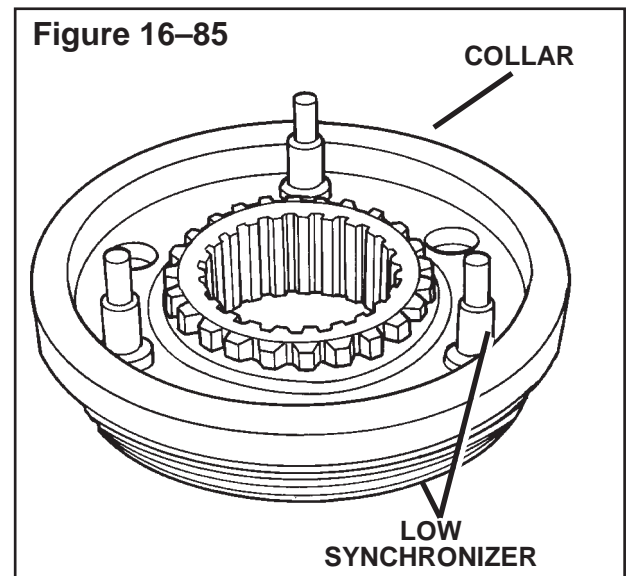

- d. Install the springs in the holes in the high synchronizer. Put grease on the springs. Use a multi-purpose lubricating grease with NLGI Number 2 rating. **Figure 16-86.**

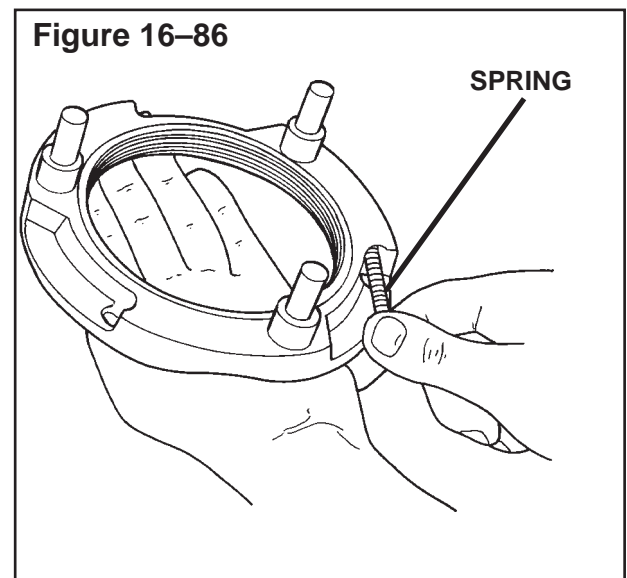

- e. Install the high synchronizer on the pins of the low synchronizer cone. Move the high synchronizer so that the springs are against the side of the pins of the low synchronizer. **Figure 16-87.**

NOTE

Put a towel under the low synchronizer to keep the assembly from moving when the high synchronizer is installed.

- f. Push down on the high synchronizer so that the pins of the low synchronizer are installed in the holes in the high synchronizer. **Figure 16-87.**

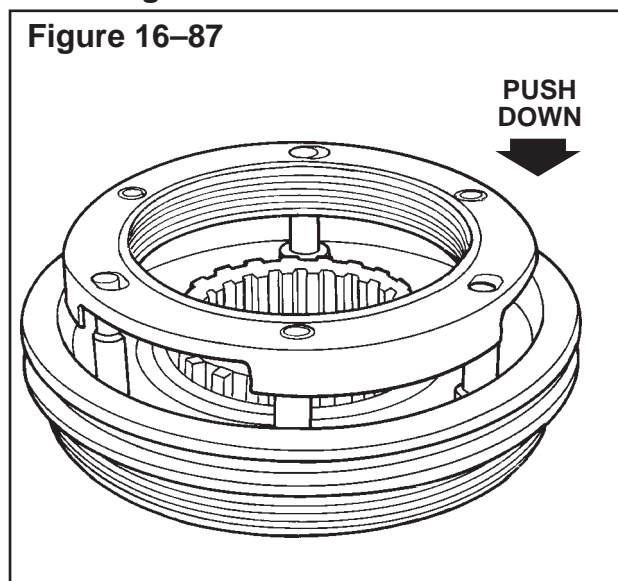

- g. Install the low synchronizer on the hub and **LO** gear assembly. **Figure 16-88.**

13. If removed, install the bearing cones and the splitter gear on the auxiliary countershafts. See the following procedure.

- a. Put the countershaft in a press so that the auxiliary gear is toward the bottom of the press. Support the countershaft on the gear.

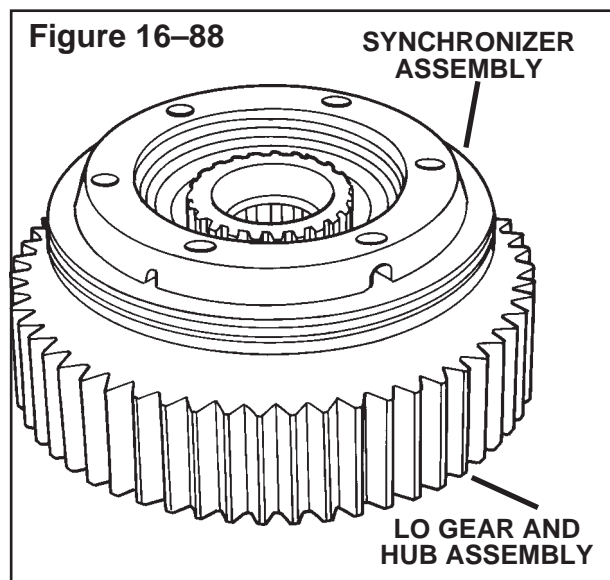

- b. Put the key in the groove on the shaft.
- c. Put the splitter gear on the shaft. Make sure the key is aligned with the slot in the gear.
- d. Put a sleeve on the gear and press the gear on the shaft.

Figure 16-89.

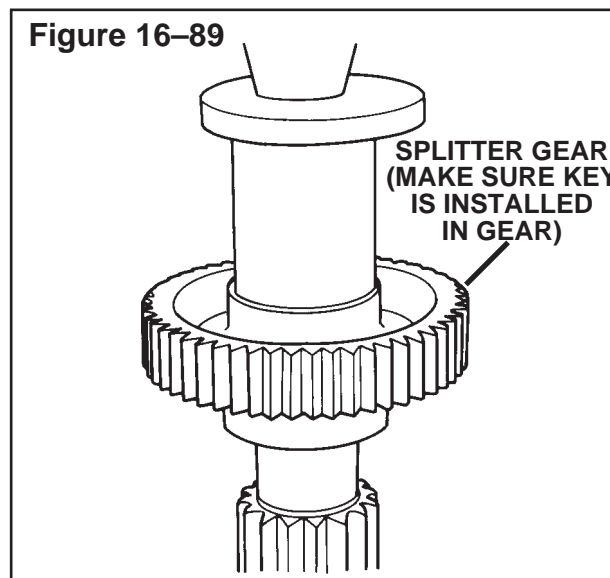

- e. Put the rear cone on the countershaft so that the bottom of the cone is toward the gear.

- f. Put a sleeve on the inner race of the cone. Press the cone on the countershaft. The cone is correctly installed when the bottom of the cone touches the gear.

Figure 16-90.

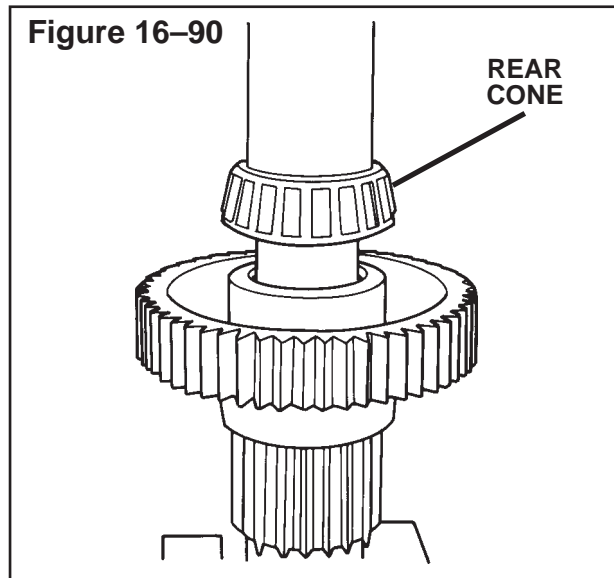

- g. Turn the countershaft over so that the splitter gear is toward the bottom of the press.
- h. Put the front cone on the countershaft so that the bottom of the cone is toward the gear.
- i. Put a sleeve on the inner race of the cone. Press the cone on the countershaft. The cone is correctly installed when the bottom of the cone touches the gear.

Figure 16-91.

- 14. Install the auxiliary countershafts in the cover. Make sure the timing marks on the **OD** gears are aligned. Make sure the countershaft bearing is completely installed in the cover. **Figure 16-92.**

Figure 16-91

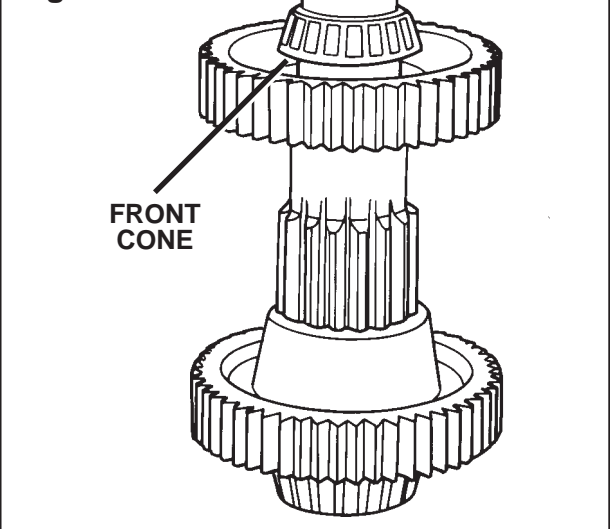
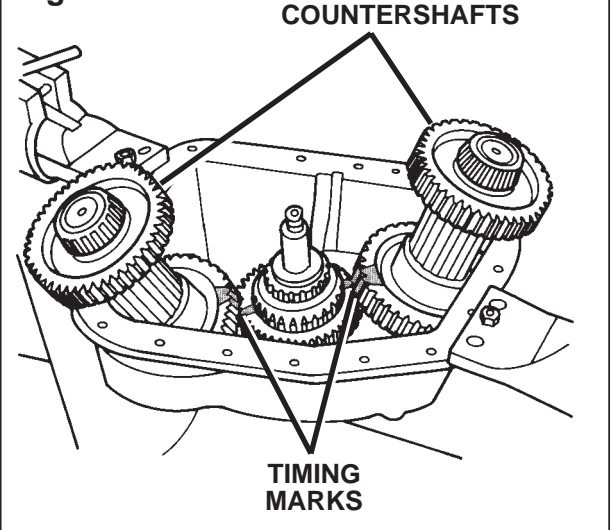
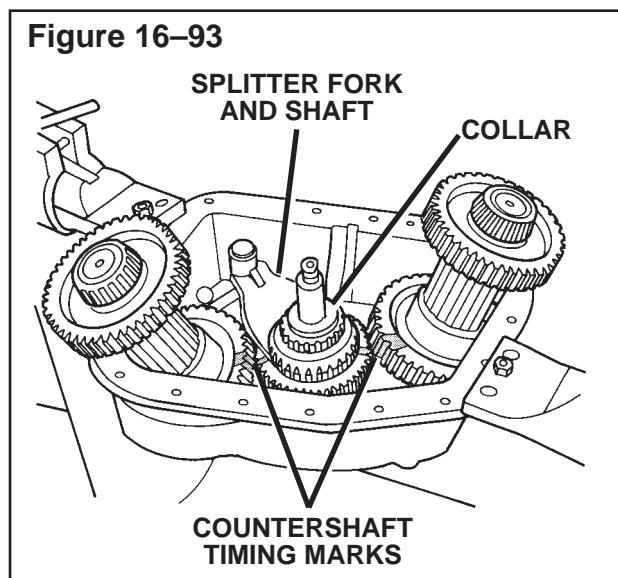

Figure 16-92



- 15. Install the collar on the output shaft. Install the splitter fork and shaft assembly on the **splitter** gear assembly. Move the fork so that the fork will not touch the **splitter** gear assembly during installation. **Figure 16-93.**



16. Install the **LO** gear and synchronizer assembly on the output shaft inside the auxiliary cover. Make sure the high synchronizer is toward you. Make sure the timing marks on all the gears are aligned. **Figure 16-94.**

NOTE

The end play of the auxiliary countershaft is checked when the auxiliary cover is installed on the transmission.

17. **On Design Level 1 Transmissions,** install the cups on the cones of the auxiliary countershafts. Install the correct selective snap rings that fastens the cups in the cover. Make sure the snap ring is completely installed in the groove. **Figure 16-95.**

On Design Level 2 Transmissions, install the cups on the cones of the auxiliary countershafts. Install the correct selective washers in front of the cups. Make sure the tabs in the washers are in the slots in the case.

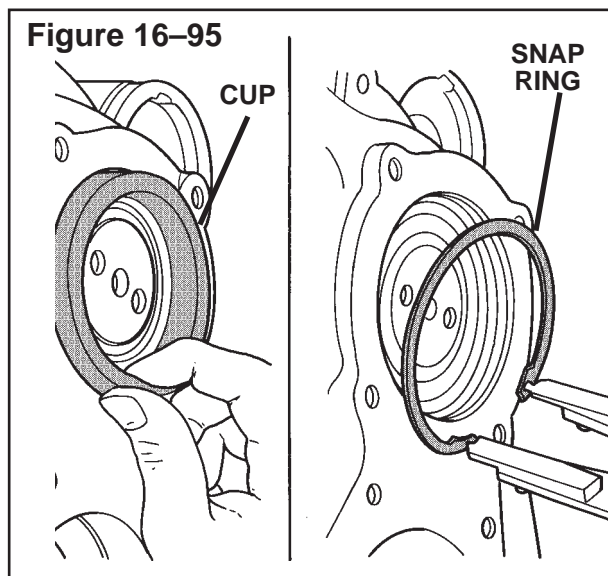
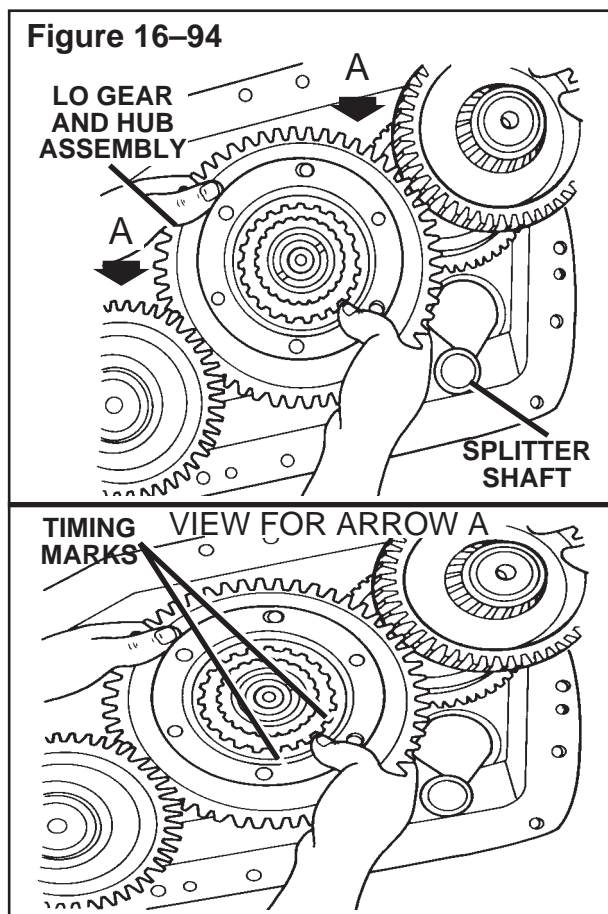

18. Put the holding plates on both auxiliary countershafts. Use capscrews to fasten the plates to the countershaft and the cover. **DO NOT CHANGE THE POSITION OF THE TRANSMISSION IN THE REPAIR STAND. Figure 16-96.**

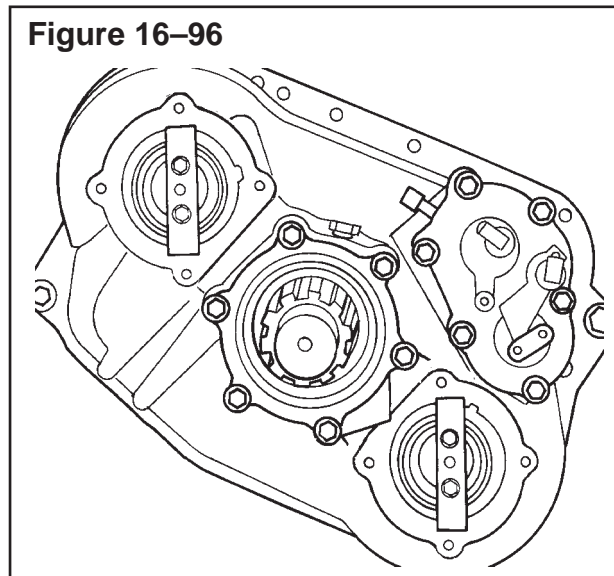

19. Install a new nut and the washer that fasten the **LO** gear to the output shaft. Tighten the nut to 220-260 lb-ft (299-352 N.m). **Figure 16-97.** **T**

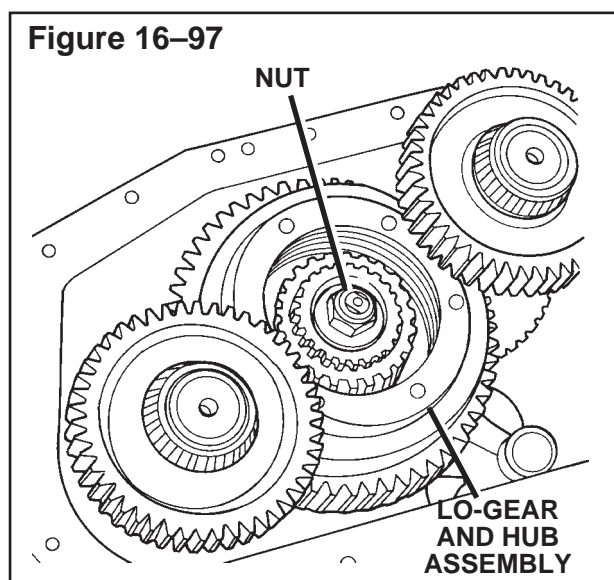

20. Put the **HI-LO** shift fork in position so that the fork engages the synchronizer collar. Make sure the bore of the fork is aligned with the bore of the piston housing. Make sure the lock pin hole in the fork is installed away from the cover. **Figure 16-98.**

21. Install the **HI-LO** shift shaft from the inside the front of the auxiliary cover. Make sure the threads on the end of the shaft are installed first. Rotate the shaft while pushing the shaft through the O-ring. **Figure 16-98.**

NOTE:

If a pin and a clip was used to fasten the HI-LO fork to the shaft, replace the pin and the clip with a nut (NL-25-1) and shoulder bolt (10-X-1534).

22. Align the hole of the shaft with the hole of the shift fork. Install the bolt and the lock nut. Tighten the nut to 8-12 lb-ft (11-16 N.m). **Figure 16-98.** **T**

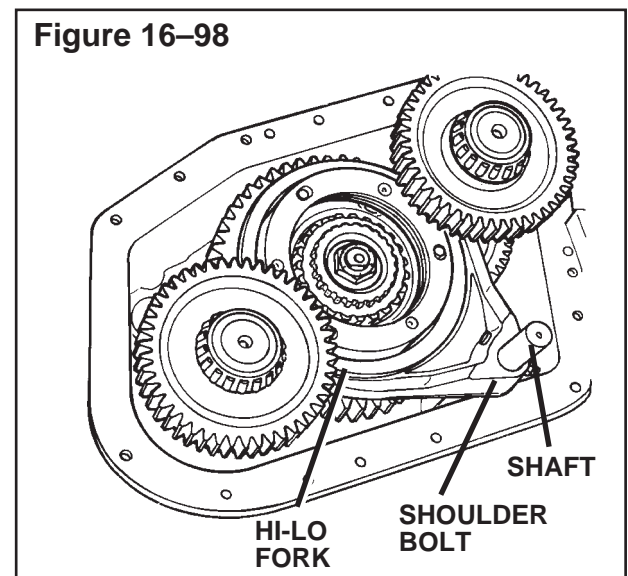

23. Move the cover in the fixture so that the outside of the cover is toward you.
24. If removed, use the correct tool to install a new bushing for the speedometer gear inside the output bearing retainer.
25. If removed, install a new oil seal in the output bearing retainer. See the following procedure. **Figure 16-99.**

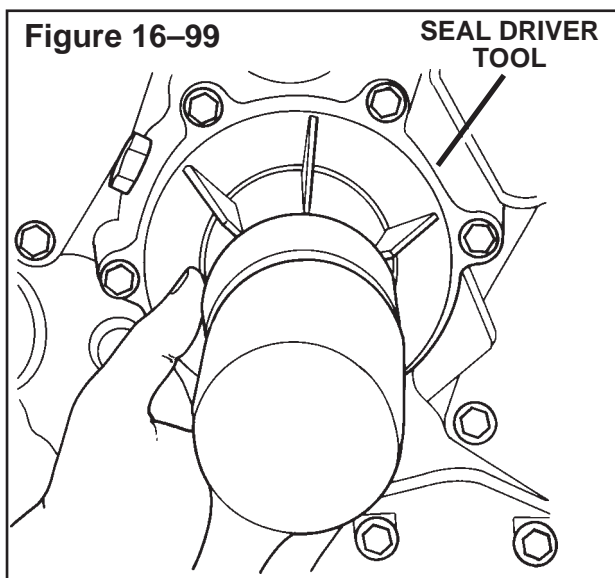

CAUTION
Hold the seal only on the outer diameter. Do not touch the inner diameter of the seal. Touching contaminates the inner diameter of the seal and causes a leak between the shaft and the seal.

- a. Lubricate the outer diameter of the seal. Put the oil seal in the cover. Make sure the letters on the seal are installed away from the retainer.

CAUTION
Use the correct tool to install the oil seal. If the correct tool is not used, the seal will leak.

- b. Use seal driver tool, 3256-Z-1014, (Kent-Moore Tool Number J-39161) to drive the seal into the cover. The seal is correctly installed when the flange of the seal touches the retainer.

26. Use a sealant dispenser and Loctite RTV Sealant, #5699 (Meritor Part Number 2297-A-7021) or equivalent to make a 1/8 inch (2 mm) gasket pattern on the cover for the output bearing retainer. See **Figure 16-100** for the gasket pattern. See "Installing the Sealant" in Section 1.
27. Install the output bearing retainer on the auxiliary cover. Make sure the oil passage in the retainer is aligned over the oil hole in the cover. **Figure 16-100.**

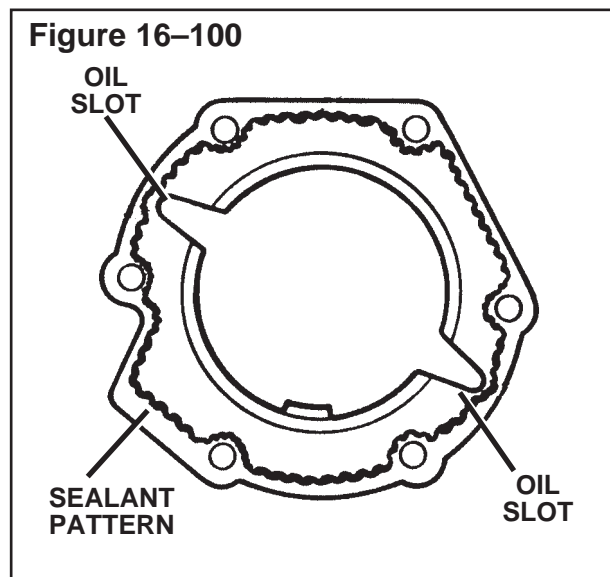

28. Install the mounting capscrews for the output bearing retainer. Tighten the capscrews to 35-45 lb-ft (47-61 N.m). **Figure 16-101.** **T**

29. Lubricate the O-rings and the bores of the piston housing with the a silicone lubricant such as Dow Corning #111 Silicone Grease or equivalent. Install the O-rings in the grooves in the bores of the piston housing. **Figure 16-101.**

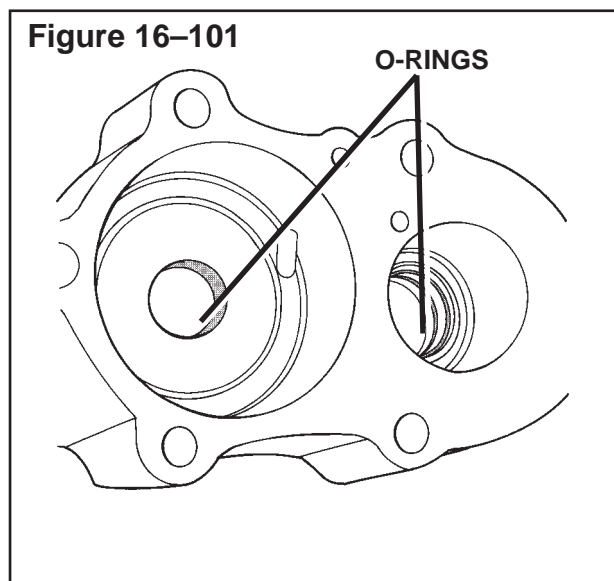

30. Use a sealant dispenser and Loctite RTV Sealant , #5699 (Meritor Part Number 2297-A-7021) or equivalent to make a gasket pattern on the piston housing. See **Figure 16-102** for the gasket pattern. See "Installing the Sealant" in Section 1.

31. Install piston housing on the auxiliary cover. Make sure the shafts are in the correct bores. **Figure 16-103.**

32. Lubricate the O-ring for the pistons with a silicone lubricant such as Dow Corning #111 Silicone Grease or equivalent. Install the O-rings on the outer diameter and in the bore of the pistons. **Figure 16-103.**

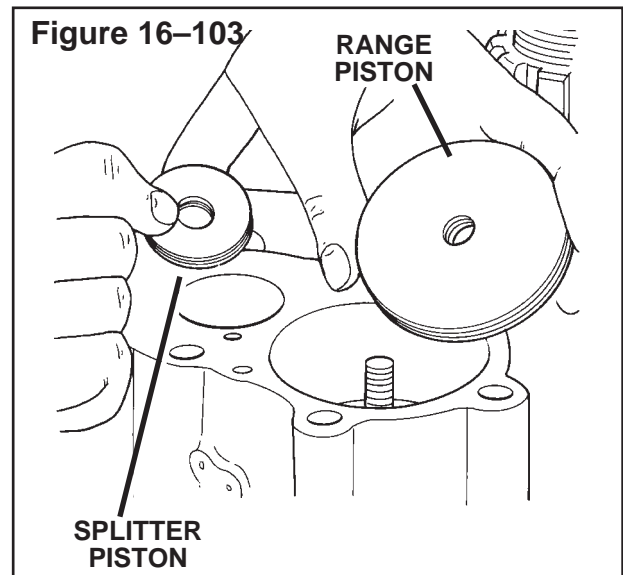
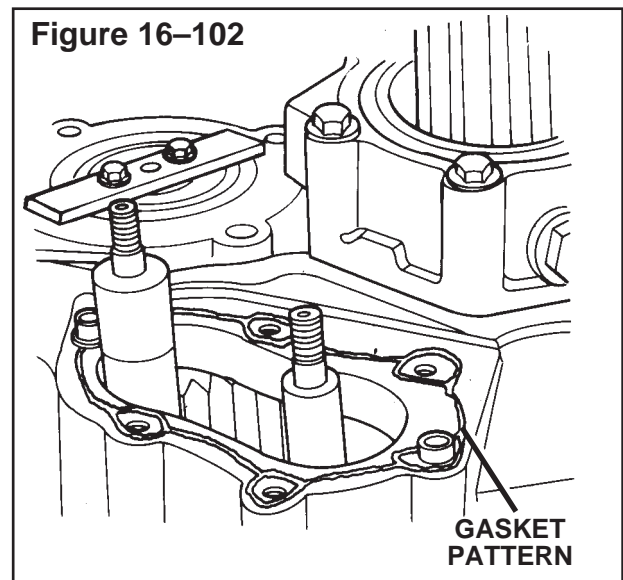

33. Install the pistons on the shafts in the piston housings. Make sure the pistons are install on the correct shafts. **Figure 16-103.**

34. Install a new nut and the washer that fasten the pistons on the shafts. Tighten the nut to 35-50 lb-ft (48-67 N.m). **Figure 16-104.** **T**

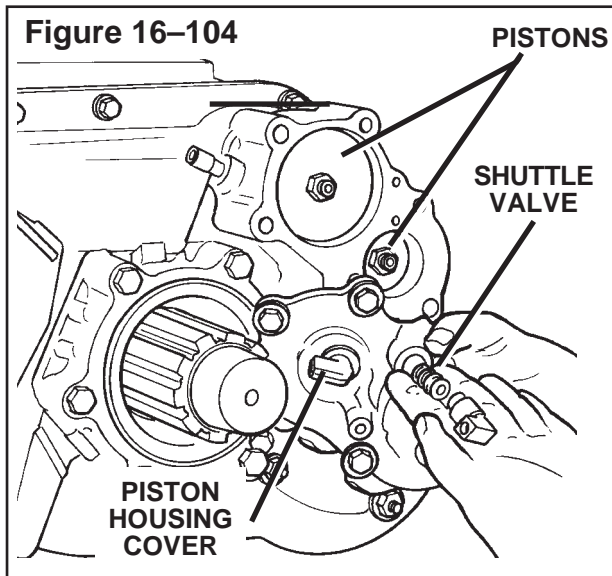

35. If removed, install the shuttle valve.

Lubricate the O-rings on the shuttle valve with a silicone lubricant such as Dow Corning #111 Silicone Grease or equivalent.

Install the shuttle valve. Make sure the rod of the valve is toward the piston. Install and tighten the fitting.

Figure 16-104.

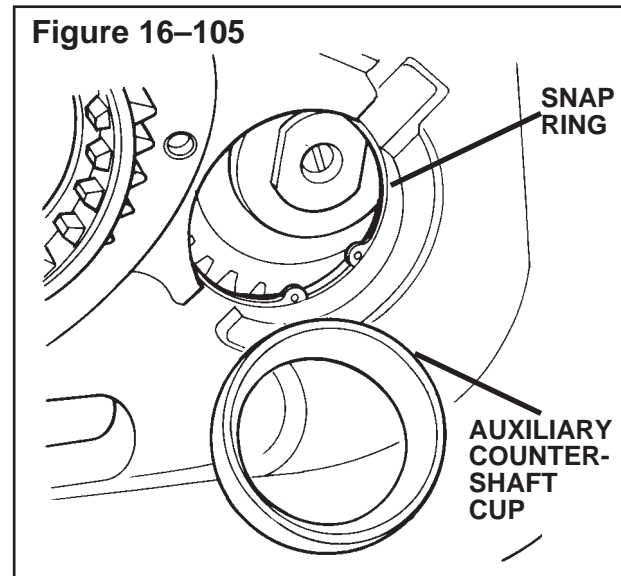

36. Install a new gasket between the piston housing and the piston housing cover.

37. Install the capscrews and the washers to fasten the piston housing cover to the piston housing. Tighten the capscrews to 35-45 lb-ft (47-61 N.m). **T**

38. Install the cups for the rear bearing cones of the auxiliary countershafts. Put the cones in the correct bores in the transmission case.

Figure 16-105.

Section 17

Main Countershaft End Play Adjustment



WARNING

To prevent serious eye injury, always wear safe eye protection when doing maintenance or service.

Checking and Adjusting the End Play of the Main Countershafts

NOTE:

Check the end play on one countershaft at a time.

1. Put the transmission in **NEUTRAL** **Figure 17-1**.

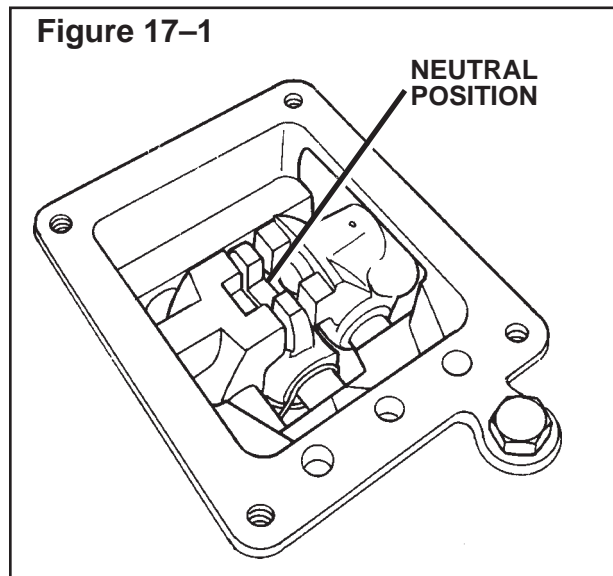

2. Install Countershaft End Play Checking Tool, Meritor Part Number 3256-C-1043, or Kent-Moore Tool Number J-41335 on the upper countershaft. See the following procedure. **Figure 17-2**.

Figure 17-2

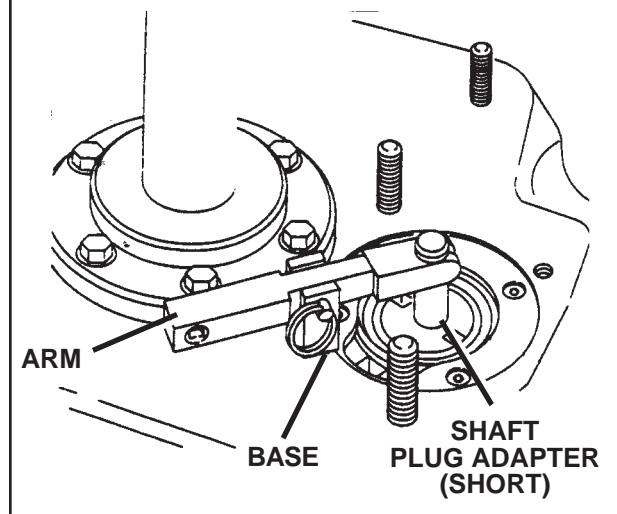

- a. Put the Shaft Plug Adapter in position on the countershaft. Install and tighten the screws that fasten the adapter to the countershaft.
- b. Install the (short) shaft plug with 5/16 inch threads into the adapter. Tighten the plug.
- c. Install the 3/8 inch base into one of the mounting holes for the clutch housing.
- d. Install the actuator arm so that the "forked" end of the arm is in the groove of the shaft plug.
- e. Align the holes in the actuator arm with the hole in the base. Install the pivot pin.

Section 17

Main Countershaft End Play Adjustment

NOTE:

Runout measurement will not occur when the output shaft is rotated if the dial indicator and the Countershaft End Play Checking Tool are correctly installed. If runout occurs make sure the tip of the dial indicator and the alignment mark on the shaft plug are aligned.

3. Install a dial indicator so that the tip of the indicator is in the center of the shaft plug. Make sure the tip of the dial indicator is also aligned with the alignment mark on the shaft plug. **Figure 17-3.**

4. Install a torque wrench in the end of the actuator arm. The torque wrench must be installed in a straight line with the actuator arm. **Figure 17-3.**

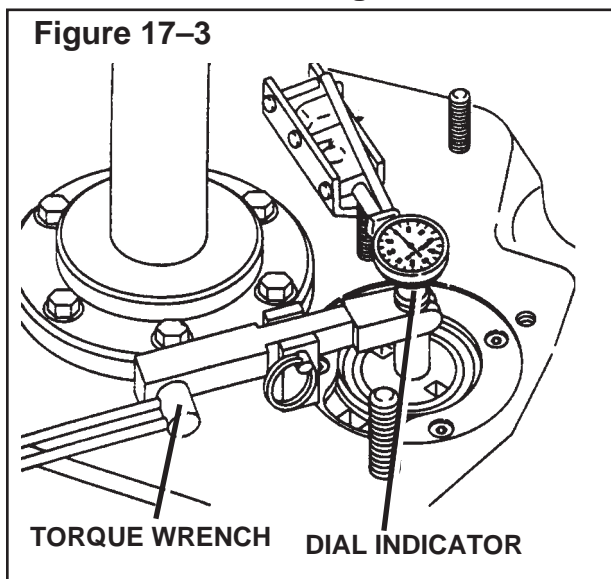

5. Measure the upper countershaft end play. See the following procedure.

NOTE

If you do not apply proper torque, repeat the procedure.

- a. Use the torque wrench to apply a force of 25 lb-ft or 300 lb-in (34 N.m) in one direction.

Figure 17-4.

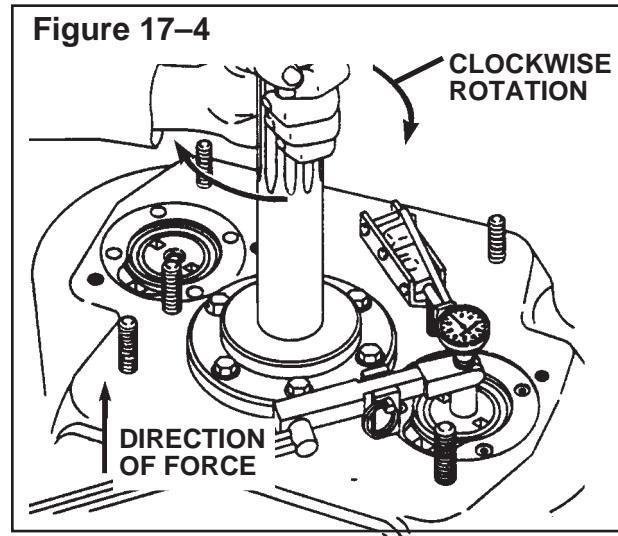

- b. Put reference marks on the input shaft and the main case. When the input shaft is rotated in this procedure, the “starting” and “stopping” positions of rotation must be in the same location.
- c. Rotate the input shaft at least four (4) complete turns in a **clockwise** direction. Make sure the “starting” and “stopping” positions of rotation are at the same location.

Figure 17-4.

- d. Set the dial indicator to “zero” (0).
- e. Change the direction of force applied in step “a” to the opposite direction.
- f. Rotate the input shaft at least four (4) complete turns in a **counter-clockwise** direction. Make sure the “starting” and “stopping” positions of rotation are at the same location. **Figure 17-5.**
- g. Record the reading on the dial indicator.

Section 17

Main Countershaft End Play Adjustment

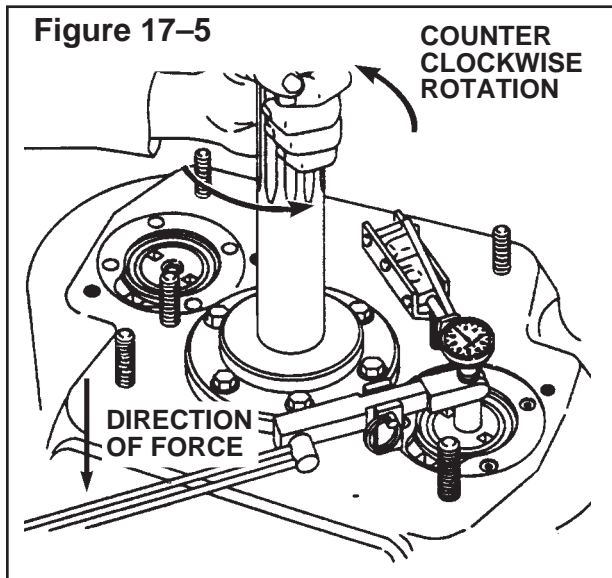

6. The correct end play specification is 0.002-0.006 inch (0.050-0.152 mm).

If the reading is 0.002-0.006 inch (0.050-0.152 mm), go to step 14.

For Design Level 1 Transmissions, If the reading is less than 0.002 inch (0.050 mm) or more than 0.006 inch (0.152 mm), see steps 7-8.

For Design Level 2 Transmissions, If the reading is less than 0.002 inch (0.050 mm) or more than 0.006 inch (0.152 mm), see steps 9-14.

7. **For Design Level 1 Transmissions,** if the reading is 0.002 inch or less, check the following:

- Check the cover of the main countershaft for damage. Replace damaged covers. Repeat steps 1-5.
- Check for dirt or other contaminants between the rear bearing cup and the case. Repeat steps 1-5.
- Remove the auxiliary case and check that the cup for the main countershaft is correctly installed in the main case. Make sure the cup is installed correctly. Repeat steps 1-5.

8. **For Design Level 1 Transmissions,** if the reading is more than 0.006 inch (0.152 mm), remove the 0.068 inch (1.73 mm) snap ring (Meritor part number 1229-C-4215) from the front bore of the main countershaft.

Use the reading to find the correct snap ring in the chart in **Figure 17-6**. Install the correct snap ring in the front bore for the main countershaft.

Figure 17-7.

END PLAY MEASUREMENT		SNAP RING THICKNESS		PART NUMBER	COLOR
INCH	MM.	INCH	MM		
0.007-0.011	0.153-0.279	0.073	1.86	1229-D-4216	Orange
0.012-0.016	0.280-0.406	0.078	1.99	1229-E-4217	White
0.017-0.021	0.407-0.533	0.083	2.12	1229-F-4218	Blue
0.022-0.026	0.534-0.660	0.088	2.25	1229-G-4219	Yellow
0.027-0.032	0.661-0.812	0.094	2.38	1229-H-4220	Green
0.033-0.037	0.813-0.939	0.099	2.51	1229-J-4222	Green/White
0.038-0.042	0.940-1.067	0.104	2.64	1229-K-4223	Blue/White
0.043-0.047	1.068-1.194	0.109	2.77	1229-L-4224	Orange/White

Section 17

Main Countershaft End Play Adjustment

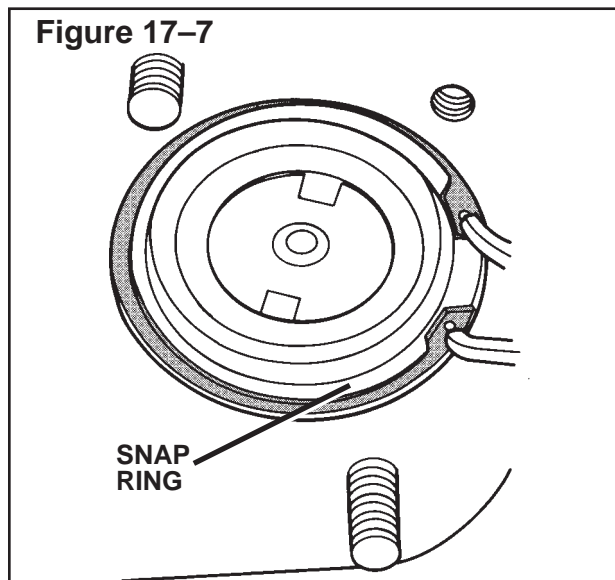

Repeat steps 1-5 to make sure the end play is correct. When the end play is correct, go to step 14.

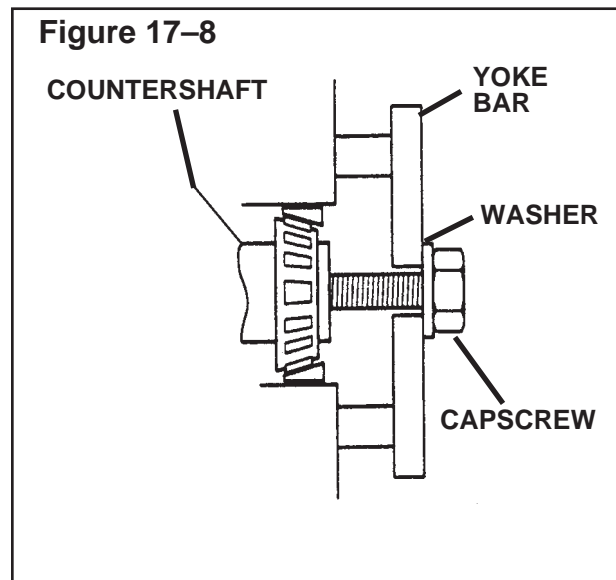

9. **On Design Level 2 Transmissions, if the reading is less than 0.002 inch (0.050 mm), or there is no reading, move the cup 0.125 inch (3 mm) toward the outer surface of the case. See the following procedure.**
- Remove the Allen-head capscrews and remove the retainer.
 - Use a yoke bar (puller bridge), washer and a long 5/16 inch x 18 capscrew to move the cup. **Figure 17-8.**
 - After the cup is moved, go to step 13 (the procedure for if the reading is 0.020 inch or more)



10. **On Design Level 2 Transmissions, if the reading is 0.007-0.011 inch (0.177-0.279 mm), see the following:**
- Remove the Allen-head capscrews and remove the retainer.
 - Remove the 0.005 inch (0.127 mm) shim (Meritor part number 2803-R-2826).
 - Install the retainer. Install the Allen-head capscrews. Alternately and evenly tighten the capscrews to 120-140 lb-in (14-16 N.m). **T**
 - Check the end play as described in steps 1-5 of this procedure.
11. **On Design Level 2 Transmissions, if the reading is 0.012-0.014 inch (0.280-0.355 mm), see the following:**
- Remove the Allen-head capscrews and remove the retainer.
 - Remove the 0.0075 inch (0.190 mm) shim (Meritor part number 2803-S-2827).

Section 17

Main Countershaft End Play Adjustment

- c. Install the retainer. Install the Allen-head capscrews. Alternately and evenly tighten the capscrews to 120-140 lb-in (14-16 N.m). 
- d. Check the end play as described in steps 1-5 of this procedure.
12. **On Design Level 2 Transmissions, if the reading is 0.015-0.019 inch (0.356-0.482 mm),** see the following:
- a. Remove the Allen-head capscrews and remove the retainer.
- b. Remove the 0.005 inch (0.127 mm) shim (Meritor part number 2803-R-2826).
- c. Remove the 0.0075 inch (0.190 mm) shim (Meritor part number 2803-S-2827).
- d. Install the retainer. Install the Allen-head capscrews. Alternately and evenly tighten the capscrews to 120-140 lb-in (14-16 N.m). 
- e. Check the end play as described in steps 1-5 of this procedure.
13. **On Design Level 2 Transmissions, if the reading is 0.020 inch (0.483 mm) or more ,** see the following:
- a. Remove the Allen-head capscrews and remove the retainer.
- b. Remove and discard all the shims, including the original shims.
- NOTE:**
Shim KIT 5364 uses the following shims:
- **Two 0.0050 inch (0.127 mm) shims.**
 - **Two 0.0075 inch (0.190 mm) shims.**
 - **One 0.0175 inch (0.444 mm) shim.**
 - **One 0.0325 inch (0.825 mm) shim.**
- The total shim pack thickness is 0.075 inch (1.903 mm)**
- c. Install shim KIT 5364 in the bore for the front countershaft bearing. Make sure the slots for the oil passage on the shims are aligned with the oil passage hole.
- d. Install the retainer for the front countershaft bearings. Install the Allen-head capscrews. Alternately and evenly tighten the capscrews to 120-140 lb-in (14-16 N.m). 
- e. Check the end play as described in steps 1-5 of this procedure.
- f. Find the end play measurement determined in step 5 of this procedure in the “Main Countershaft End Play Chart for Shim KIT 5364” in **Figure 17–9**. Remove shims to get the specified end play of 0.002-0.006 inch (0.050-0.152 mm).
- g. Check end play again. Make sure the front cup touches the retainer. If the reading is 0.002-0.006 inch (0.050-0.152 mm), the end play is correct. See step 14.

Section 17

Main Countershaft End Play Adjustment

Figure 17-9

Main Countershaft End Play Chart for Shim KIT 5364

END PLAY MEASUREMENT		REMOVE THESE SHIMS			
		2803-R-2826 (0.0050 INCH OR 0.127 MM)	2803-S-2827 (0.0075 INCH OR 0.190 MM)	2803-W-2831 (0.0175 INCH OR 0.444 MM)	2803-C-2837 (0.0325 INCH OR 0.825 MM)
INCHES	MM.				
0.002-0.007	0.050-0.177	----	----	----	----
0.008-0.010	0.178-0.254	1	----	----	----
0.011-0.012	0.255-0.304	----	1	----	----
0.013-0.015	0.305-0.381	2	----	----	----
0.016-0.017	0.382-0.431	1	1	----	----
0.018-0.020	0.432-0.508	2	----	----	----
0.021-0.022	0.509-0.558	----	----	1	----
0.023-0.025	0.559-0.635	2	2	----	----
0.026-0.027	0.636-0.685	1	1	----	----
0.028-0.030	0.686-0.762	----	1	1	----
0.031-0.032	0.763-0.812	1	----	1	----
0.033-0.035	0.813-0.889	1	1	1	----
0.036-0.037	0.890-0.939	----	----	----	1
0.038-0.040	0.940-1.016	2	1	1	----
0.041-0.042	1.017-1.066	1	----	----	1
0.043-0.045	1.067-1.143	----	1	----	1
0.046-0.047	1.144-1.193	2	----	----	1
0.048-0.050	1.194-1.270	1	1	----	1
0.051-0.052	1.271-1.320	----	1	----	2
0.053-0.055	1.321-1.397	----	----	1	1
0.056-0.057	1.398-1.447	1	2	----	1
0.058-0.060	1.448-1.524	1	----	1	1
0.061-0.062	1.525-1.574	----	1	1	1
0.063-0.065	1.575-1.651	2	----	1	1
0.066-0.067	1.652-1.701	1	1	1	1
0.068-0.070	1.702-1.778	----	2	1	1
0.071-0.072	1.779-1.828	2	1	1	1
0.073-0.075	1.829-1.905	1	2	1	1
0.076 and above	1.906 and above	2	2	1	1

Section 17

Main Countershaft End Play Adjustment

14. Repeat steps 1-5 and check the end play of the other main countershaft.
15. **On Design Level 1 Transmissions**, when the end play is 0.002 -0.006 inch (0.050-0.152 mm) on each countershaft, repeat steps 1-5 on each countershaft to make sure the end play is correct.

If end play is correct, return to step 13 in Section 12, "Overhauling the Main Case". If end play is not correct, repeat the procedure in this section.

16. **On Design Level 2 Transmissions**, when the end play is 0.002 -0.006 inch (0.050-0.152 mm) on each countershaft, do the following:
 - a. Remove the Allen-head capscrews that fasten the retainer to the main case.
 - b. Apply Loctite® #222 or equivalent to the threads of the capscrews.
 - c. Install the capscrews. Alternately and evenly tighten the capscrews to 120-140 lb-in (14-16 N.m)

Figure 17-10. 

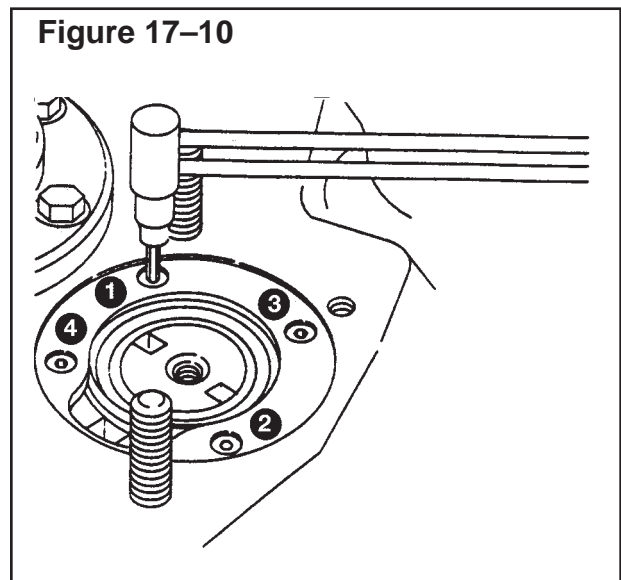

- d. Repeat steps 1-5 of this procedure to make sure the end play is correct.
- e. If end play is correct, return to step 13 in Section 12, "Overhauling the Main Case). If end play is not correct, repeat the procedure in this section.

Section 18

Auxiliary Countershaft End Play Adjustment



WARNING

To prevent serious eye injury, always wear safe eye protection when doing maintenance or service.

Checking and Adjusting the End Play of the Auxiliary Countershaft

NOTE:

Check the end play on one countershaft at a time.

1. Install the auxiliary case on the main case as described in Section 11, "Removing and Installing the Auxiliary Case".
2. **On Design Level 1 Transmissions**, discard the selective snap ring that is used to fasten the cup in the bore. Install a spacer washer to adjust the end play.
3. Remove the capscrews and the washers that fasten the Holding Cover Plates and/or lift brackets on the countershaft and cover. Remove the cover tool.



CAUTION

Use spacer washer, Part Number 1229-N-4538 (with blue color) to check the end play of the auxiliary countershaft. If the wrong spacer washer is used, the end play reading will not be correct.

4. Install the thinnest spacer washer, Meritor Part Number 1229-N-4538 (with blue color), in the bore on top of the cup. Make sure the tab of the washer is aligned with the slot in the case. **Figure 18-1.**

Figure 18-1

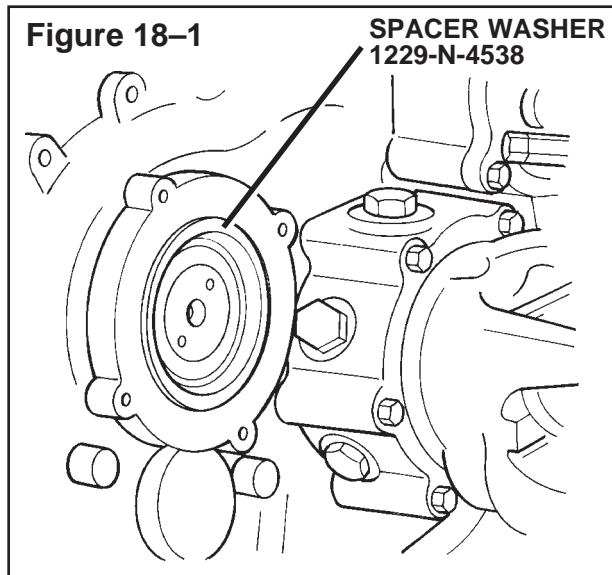

5. Make sure the bearing cup and the spacer washer are in the correct position. See the following procedure. **Figure 18-2.**

Figure 18-2

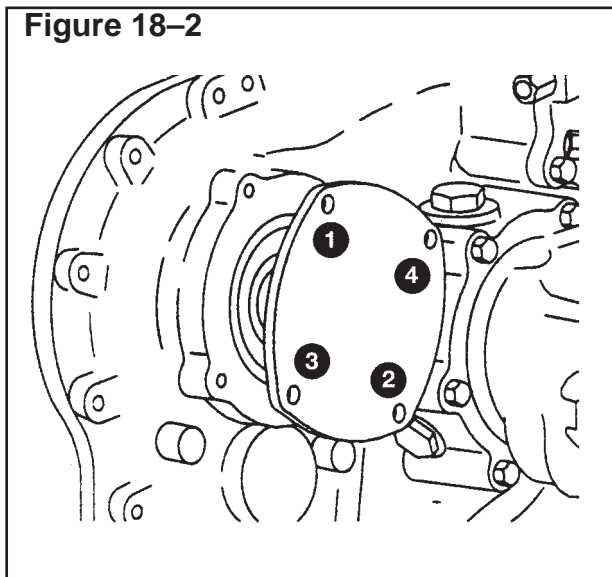

- a. Install the cover for auxiliary countershaft.
- b. Install the capscrews and washers that fasten the cover to the auxiliary case.

Section 18

Auxiliary Countershaft End Play Adjustment

- c. Alternately and evenly tighten the capscrews until the countershaft cover touches surface of the auxiliary cover. **DO NOT TIGHTEN MORE THAN 35 LB-FT (47 N.m).**



- d. Remove the capscrews, the washers and the countershaft cover.

NOTE:

Two designs of countershafts are used: a single-hole design and a two-hole design. The Countershaft End Play Checking Tool is installed differently on each design.

- 6. Install Countershaft End Play Checking Tool, Meritor Part Number 3256-C-1043, or Kent-Moore Tool Number J-41335 on the countershaft. See the following procedure.

Two-Hole Design Countershaft

See Figure 18-3.

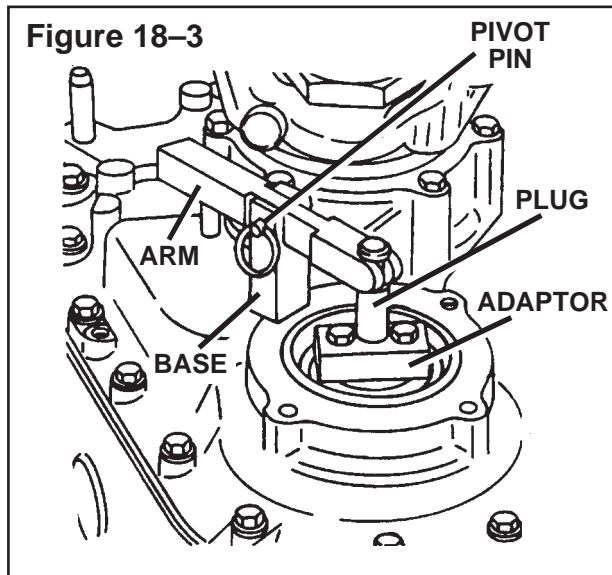

- a. Put the Shaft Plug Adapter in position on the countershaft. Install and tighten the screws that fasten the adapter to the countershaft.

- b. Install the (short) shaft plug with 5/16 inch threads into the adapter. Tighten the plug.
- c. Install the 3/8 inch base for two-hole countershafts into one of the mounting holes for the countershaft cover.
- d. Install the actuator arm so that the "forked" end of the arm is in the groove of the shaft plug.
- e. Align the holes in the actuator arm with the hole in the base. Install the pivot pin.

Single-Hole Design Countershaft

See Figure 18-4.

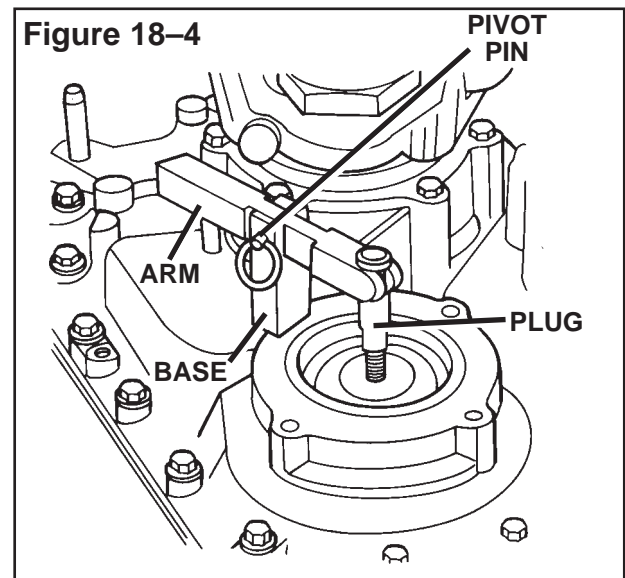

- a. Install the (short) shaft plug with 3/8 inch threads into the countershaft. Tighten the plug.
- b. Install the 3/8 inch base for single-hole countershafts into one of the mounting holes for the countershaft cover.
- c. Install the actuator arm so that the "forked" end of the arm is in the groove of the shaft plug.

Section 18

Auxiliary Countershaft End Play Adjustment

- d. Align the holes in the actuator arm with the hole in the base. Install the pivot pin.

NOTE:

Runout measurement will not occur when the output shaft is rotated if the dial indicator and the Countershaft End Play Checking Tool are correctly installed. If runout occurs make sure the tip of the dial indicator and the alignment mark on the shaft plug are aligned.

7. Install a dial indicator so that the tip of the indicator is in the center of the shaft plug. Make sure the tip of the dial indicator is also aligned with the alignment mark on the shaft plug. **Figure 18-5.**
8. Install a torque wrench in the end of the actuator arm. The torque wrench must be installed in a straight line with the actuator arm. **Figure 18-5.**

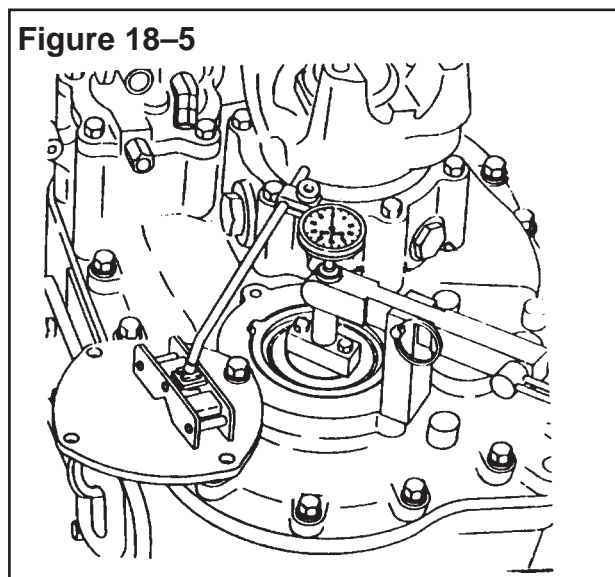

9. Measure the auxiliary countershaft end play. See the following procedure.

CAUTION

Apply the force on the torque wrench until after the end play is checked. If the force is released, the procedure must be repeated.

- a. Use the torque wrench to apply a force of 25 lb-ft or 300 lb-in (34 N.m) in one direction. **Figure 18-6.**

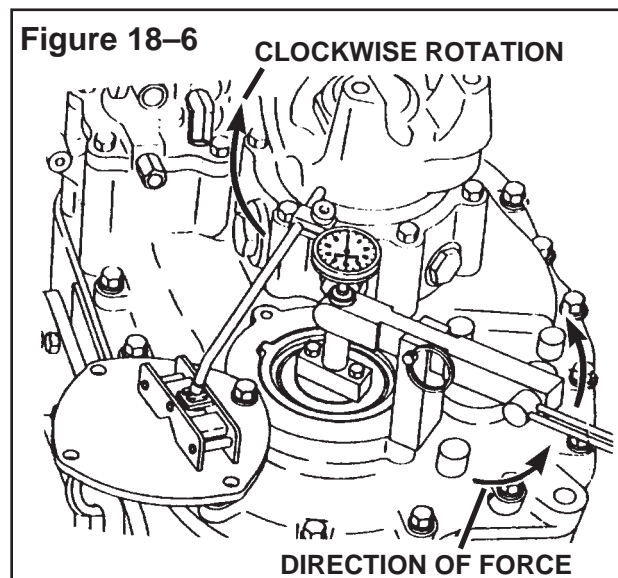

- b. Put reference marks on the output shaft and the auxiliary case. When the output shaft is rotated in this procedure, the “starting” and “stopping” positions of rotation must be in the same location.
- c. Rotate the output shaft at least four (4) complete turns in a **clockwise** direction. Make sure the “starting” and “stopping” positions of rotation are at the same location.

Figure 18-6.

Section 18

Auxiliary Countershaft End Play Adjustment

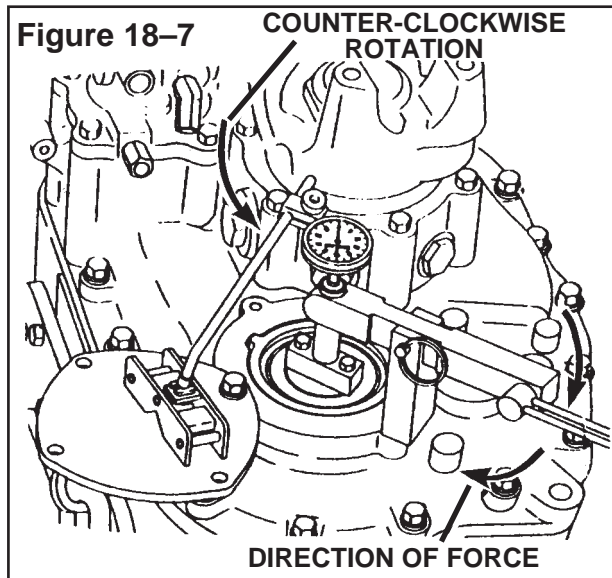

- d. Set the dial indicator to “zero” (0).
- e. Change the direction of force applied in step “a” to the opposite direction.
- f. Rotate the output shaft at least four (4) complete turns in a **counter-clockwise** direction. Make sure the “starting” and “stopping” positions of rotation are at the same location. **Figure 18-7.**
- g. Record the reading on the dial indicator.

10. The correct end play specification is 0.002-0.006 inch (0.050-0.152 mm).

If the reading is less than 0.002 inch (0.050 mm) or there is no reading on the dial indicator, see step 11.

If the reading is 0.007 inch (0.177 mm) or more, see step 12.

If the reading is 0.002-0.006 inch (0.050-0.152 mm), the end play is correct. See step 13.

11. If the reading is less than 0.002 inch (0.050 mm), or there is no reading, move the cup 0.125 inch (3 mm) toward the outer surface of the case. Use a yoke bar (puller bridge), washer and a long 5/16 inch x 18 capscrew to move the cup. **Figure 18-8.**

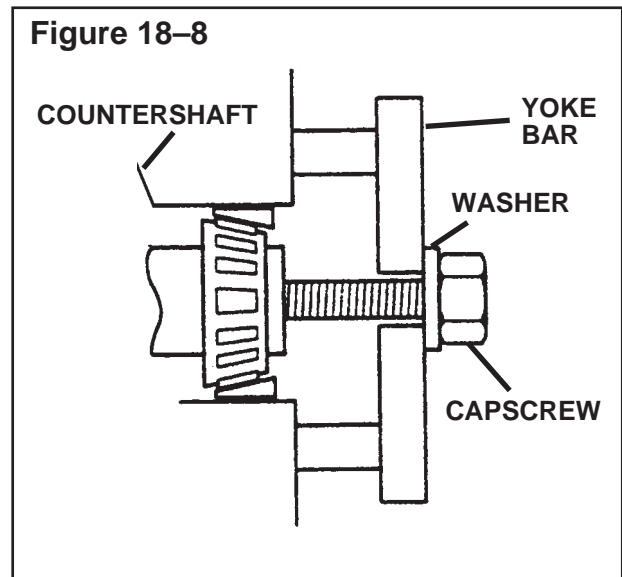

If the reading is less than 0.002 inch (0.050 mm), or there is no reading, check the following.

- Check the cover of the auxiliary countershaft for damage. Replace damaged covers. Repeat steps 6-9.
- Check for dirt or other contaminants between the rear bearing cup and the case. Repeat steps 6-9.
- Remove the auxiliary case and check that the front cup for the auxiliary countershaft is correctly installed in the main case. Check the cover of the auxiliary countershaft for damage. Make sure the cup is installed correctly. Repeat steps 6-9.

Section 18

Auxiliary Countershaft End Play Adjustment

12. If the reading is 0.007 inch (0.177 mm) or more, the end play must be adjusted. See the following.
 - a. Choose the correct spacer washer according to the dial indicator reading in step 9. See the chart in **Figure 18–9** to choose the correct spacer washer.
 - b. Remove the Countershaft End Play Checking Tool.
 - c. Remove the blue spacer washer (Part Number 1229-N-4538) that was used to check the end play.

Figure 18–9

End Play Measurement		Spacer Washer Color	Spacer Washer Thickness		Spacer Washer Part Number
Inch	MM.		Inch	MM.	
0.002-0.006	0.050-0.176	Blue	0.253	6.426	1229-N-4538
0.007-0.012	0.177-0.329	Green	0.258	6.553	1229-P-4540
0.013-0.017	0.330-0.456	Yellow	0.264	6.705	1229-Q-4541
0.018-0.022	0.457-0.583	White	0.269	6.832	1229-R-4542
0.023-0.027	0.584-0.710	Purple	0.274	6.956	1229-S-4543
0.028-0.032	0.711-0.837	Orange	0.279	7.086	1229-T-4544
0.033-0.038	0.838-0.989	White/Blue	0.284	7.213	1229-U-4545
0.039-0.043	0.990-1.116	White/Green	0.290	7.366	1229-V-4546
0.044-0.048	1.117-1.243	White/Yellow	0.295	7.493	1229-W-4547
0.049-0.053	1.244-1.370	White/Purple	0.300	7.620	1229-X-4548
0.054-0.058	1.371-1.497	White/Orange	0.305	7.747	1229-Y-4549
0.059 and above	1.498 and above	*	----	-----	-----

NOTES

- * If the reading is 0.059 inch (1.498 mm), or there is no reading, check the following.
- Check for dirt or other contaminants between the rear bearing cup and the case.
 - Remove the auxiliary case and check that the front cup for the auxiliary countershaft is correctly installed in the main case. Check the cover of the auxiliary countershaft for damage. Make sure the cup is installed correctly.

Section 18

Auxiliary Countershaft End Play Adjustment

- d. Install the correct spacer washer in the bore on top of the cup. Make sure the tab of the washer is aligned with the slot in the case.

Figure 18-10.

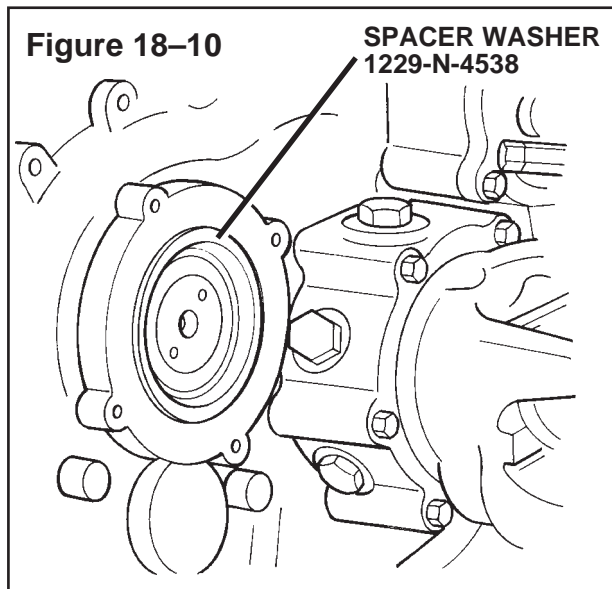

- e. Install the cover for auxiliary countershaft.
- f. Install the capscrews and washers that fasten the cover to the auxiliary case.
- g. Alternately and evenly tighten the capscrews until the countershaft cover touches surface of the auxiliary cover. **DO NOT TIGHTEN MORE THAN 35 LB-FT (47 N.m).**



- h. Remove the capscrews, the washers and the countershaft cover.
- i. Again check the end play for the auxiliary countershaft. See steps 2-9.

13. Use a sealant dispenser and Loctite® RTV Sealant™, #5699 (Meritor Part Number 2297-A-7021) or equivalent, to put a 1/8 ind (2 mm) new sealant pattern for the cover of the auxiliary countershaft in the pattern shown in **Figure 18-11**. See 'Gasket Sealant'

Figure 18-11

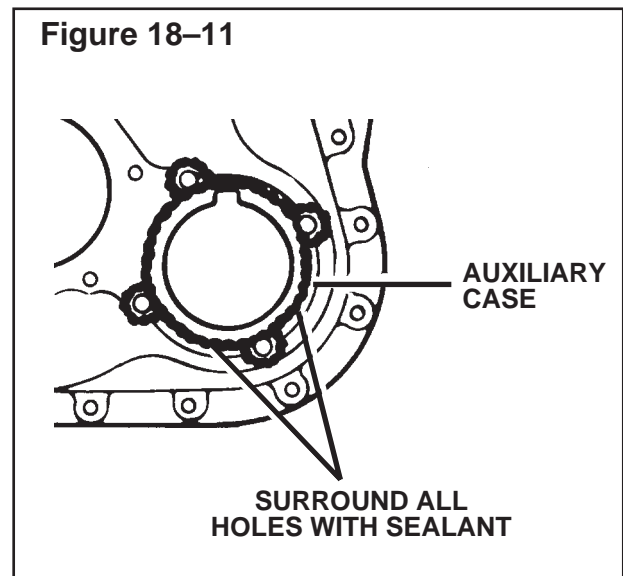

in Section 1.

14. Install the cover for the auxiliary countershaft on the auxiliary case. Install the capscrews and the washers. Tighten the capscrews to 25-35 lb-ft (34-47 N.m). **Figure 18-12.**



Section 18

Auxiliary Countershaft End Play Adjustment

Figure 18-12

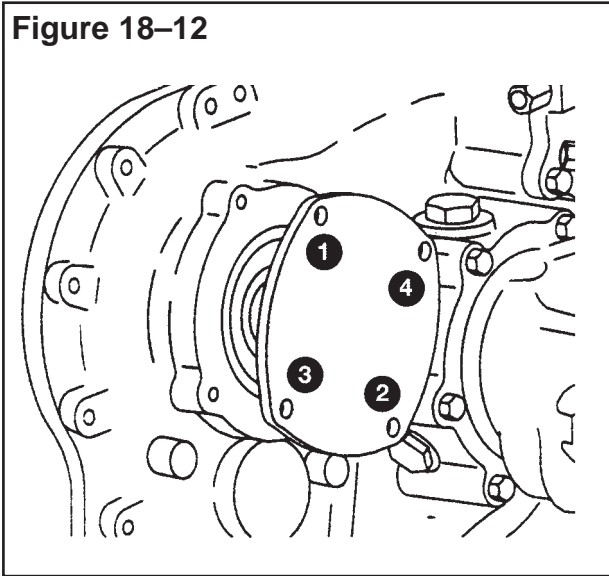

NOTE:

Different end play measurements of each countershaft are a normal condition.

15. Repeat steps 2-12 and check the end play of the other auxiliary countershaft.
16. When the end play of 0.002 - 0.006 inch (0.050-0.152 mm) is obtained, do the following:
 - **On Nine-Speed and Ten-Speed Transmissions**, go to step 14 under “Installing the Auxiliary Cover — Nine-Speed and Ten-Speed Transmissions” in Section 11, Removing and Installing the Auxiliary Cover”.
 - **On Thirteen-Speed Transmissions**, go to step 14 under “Installing the Auxiliary Cover — Thirteen-Speed Transmissions” in Section 11, Removing and Installing the Auxiliary Cover”.

General Information

When checking a problem with the manual transmission, the first thing to do is to make sure of the service condition. Talk to the driver, the mechanic or the service manager. If possible, take the vehicle for a road test.

There are three types of problems:

- Leaks.
- Noise and/or vibration.
- Operating conditions.

Oil Leaks

Check the transmission for transmission oil leaks. If you find oil on or under the transmission, verify that the leak is transmission oil and not engine oil, coolant or other lubricants. Note that under normal conditions, the area around the oil seal, yoke and rear bearing retainer is moist. This moist condition is not a transmission leak or an oil seal leak. (Refer to Section 3, "Removing the Output Yoke and the Oil Seal," for instructions on how to determine an oil seal leak.)

On New Transmissions

The following conditions can be found on new transmissions and are not considered oil leaks:

- Lubricants applied to the yoke during assembly can make the seal area appear moist or "leaking."
- All output seals are pre-lubed with grease that melts at low temperatures. When the grease melts, it comes out of the seals, and the seals only appear to be "leaking."

Vibration

When checking a noise or a vibration, find out when the problem occurs.

- When the transmission is in **NEUTRAL** or in gear.
- During upshifts or downshifts.
- In all gears or specific gears.
- In the **HI** range or the **LO** range.
- In the **DIR** range or the **OD** range. (Thirteen-Speed Transmission Only)
- During coast or acceleration.
- With the vehicle loaded or unloaded.

Noise

If a noise is the problem, find out the sound of the noise.

- Growling, humming or grinding.
- Hissing, thumping or bumping.
- Rattles.
- Squealing.
- Whining.

Operation Problems

When the transmission is not operating correctly, find out when the problem occurs.

- In **NEUTRAL** or in gear.
- During upshifts or downshifts.
- In the **HI** range or the **LO** range.
- In the **DIR** range or the **OD** range. (Thirteen-Speed Transmission Only)

Also, find out what the transmission does during the problem.

- Does not stay in the selected gear.
- Does not stay in the selected range.
- Does not select all gears.
- Does not select all ranges.
- Overheats.
- Does not operate.

Section 19

Troubleshooting

Troubleshooting Other Systems

See the following chart to make sure the transmission is the cause of the problem.

SYSTEM	CHECK FOR	REPAIRS
Engine Systems	<ol style="list-style-type: none"> 1. Loose or missing fasteners. 2. Engine idle speed out-of-specifications. 3. Loose or damaged engine mounts. 4. Out-of-balance fan. 5. Damaged engine fan. 	<ol style="list-style-type: none"> 1. Replace missing fasteners. Tighten to specified torque. 2. Adjust idle speed to the specified range. 3. Tighten the fasteners to the specified torque. Replace damaged mounts. 4. Replace fan. 5. Repair or replace as required.
Clutch Systems.	<ol style="list-style-type: none"> 1. Loose or missing fasteners. 2. Clutch out-of-adjustment. 3. Clutch assembly out-of-balance. 4. Worn or damaged pilot bearing. 	<ol style="list-style-type: none"> 1. Replace missing fasteners. Tighten to specified torque. 2. Adjust clutch 3. Replace clutch assembly. 4. Replace pilot bearing.
Driveshaft Systems.	<ol style="list-style-type: none"> 1. Driveshaft system requires lubrication. 2. Worn or damaged U-joints and/or yokes. 3. Driveshaft out-of-balance. 4. Center bearings not installed correctly or damaged. 5. Driveline angles not correct. 	<ol style="list-style-type: none"> 1. Lubricate driveshaft system. 2. Replace U-joints and/or yokes. 3. Balance driveshaft correctly or replace driveshaft. 4. Install center bearings correctly or replace. 5. Adjust driveline angles to manufacturer's specifications.
Suspension Systems.	<ol style="list-style-type: none"> 1. Loose or missing fasteners. 2. Damaged suspension components. 3. Driveline touching frame. 4. Loose or damaged cab mounts. 5. Leaks in air suspension system. 	<ol style="list-style-type: none"> 1. Replace missing fasteners. Tighten to specified torque. 2. Repair or replace damaged suspension components. 3. Adjust so that driveline does not touch frame. 4. Tighten loose fasteners to the specified torque. Replace damaged mounts. 5. Repair leaks. Check all valves for correct operation.
Power Take-Off (PTO) Systems	<ol style="list-style-type: none"> 1. PTO does not engage or disengage correctly. 	<ol style="list-style-type: none"> 1. Repair or replace PTO assembly.
Wheels and Tires	<ol style="list-style-type: none"> 1. Wheels and tires out-of-balance. 2. Tires do not match on each side of the vehicle. 	<ol style="list-style-type: none"> 1. Balance or replace wheels and tires. 2. Install tires of the same size on all sides of the vehicle.
Remote Shift Systems	<ol style="list-style-type: none"> 1. Low lubricant level. 2. Linkage out-of-adjustment. 3. Linkage binding or unable to move. 	<ol style="list-style-type: none"> 1. Fill to specified level. 2. Adjust linkage. 3. Lubricate, repair or replace linkage.

Troubleshooting Leaks

Before troubleshooting a leak condition, make sure of the following:

1. Clean the outside of the transmission to remove all dirt.
2. Operate the vehicle to make sure the leak is coming from the transmission.
3. Verify that the fluid is transmission oil.
4. The transmission housings are not cracked or broken.

CONDITION	CAUSE	REPAIR
Leaks - In-Vehicle Repair.	<ol style="list-style-type: none"> 1. Missing fasteners. 2. Loose fasteners. 3. High oil level. 4. Unspecified oil in transmission. 5. Clogged or dirty breather vent. 6. Damaged yoke. 7. Damaged output shaft seal. 8. Worn or damaged sealing tape on electronic speed sensor. 	<ol style="list-style-type: none"> 1. Replace missing fasteners. Tighten to specified torque. 2. Tighten to specified torque. 3. Drain to specified level. See "overheating" in "Operating Conditions". 4. Drain oil. Install specified oil. 5. Clean breather vent. 6. Replace yoke.① 7. Replace output shaft seal. ① 8. Install new sealing tape on electronic speed sensor.
Leaks - Remove and Disassemble Transmission.	<ol style="list-style-type: none"> 1. Damaged gaskets or sealing material. 2. Cracked or broken housing. 3. Oil leaking from breather vent. ② 	<ol style="list-style-type: none"> 1. Replace gaskets or sealing material. 2. Replace housing. 3. Replace O-ring in piston housing.

NOTES:

- ① If the transmission continues to leak and the output shaft seal and the yoke have been replaced, remove and replace the output shaft assembly.
- ② Put the transmission in the LO range and operate the vehicle. If air leaks from the breather vent, the O-ring in the housing of the range cylinder is damaged.

Troubleshooting Vibrations

Before troubleshooting a vibration condition, make sure of the following:

1. The engine idle speed is within the specified range.
2. The engine is operating correctly.
3. The U-joints, yokes and driveshaft are in good condition. Check the driveline angles. Correct as necessary.
4. The U-joints, the yokes and the driveshafts are correctly aligned and/or balanced. Correct as necessary.
5. Check air bag height. Correct as necessary.

CONDITION	CAUSE	REPAIR
Vibration - In-Vehicle Repair.	<ol style="list-style-type: none"> 1. Fasteners do not remain tight. 	<ol style="list-style-type: none"> 1. Tighten fasteners. If fasteners do not remain tight, replace fasteners or housing.
Vibration - Remove and Disassemble Transmission.	<ol style="list-style-type: none"> 1. Damaged bearings. 2. Broken or loose synchronizer pins. ③ 	<ol style="list-style-type: none"> 1. Replace bearings. 2. Replace synchronizer.

NOTES:

- ③ If the transmission does not shift correctly into the selected range, broken or loose synchronizer pins are the result of the vibration condition.

Section 19

Troubleshooting

Troubleshooting Noises

For all noise conditions, check the following before disassembling the transmission:

1. Check that the oil level is even with the bottom of the fill plug hole.
2. Make sure the correct oil is used.
3. Make sure the driveline angles of the transmission are correct.
4. Make sure the transmission is correctly installed.
5. Remove the drain plug. Check for any metal shavings, gasket material or any other material in the oil.

In some noise conditions, there are additional repairs to perform. These repairs will be explained in the following charts. See the following charts to troubleshoot the clutch.

CONDITION	CAUSE	REPAIR
Growling, Humming or Grinding ①	<ol style="list-style-type: none"> 1. Worn or damaged gears. 2. Worn bearings (Humming only). 3. End play out-of-specifications. 	<ol style="list-style-type: none"> 1. Replace gears. 2. Replace bearings. 3. Check and adjust end play.
Hissing, Thumping or Bumping ②	<ol style="list-style-type: none"> 1. Damaged bearings (Hissing only). 2. Damaged gear teeth (Thumping or bumping only). 	<ol style="list-style-type: none"> 1. Replace bearings. 2. Replace gears.
Rattles - In-Vehicle Repair	<ol style="list-style-type: none"> 1. Engine idle speed not within specifications. 2. Engine does not operate on all cylinders. 3. Clutch intermediate or center plate binding in housing. ③ 4. Other systems. 5. Incorrect shim installation on the PTO unit. 	<ol style="list-style-type: none"> 1. Adjust idle speed to specified RPM. 2. Adjust or repair engine. 3. Repair or replace intermediate or center plate. 4. Make sure the transmission is the source of the rattle condition. 5. Install correct shims on PTO unit.
Rattles - Remove and Disassemble Transmission.	<ol style="list-style-type: none"> 1. Damaged washers between mainshaft gears. 	<ol style="list-style-type: none"> 1. Replace washers between mainshaft gears.
Squealing or Whining - In-Vehicle Repair ④	<ol style="list-style-type: none"> 1. Incorrect shim installation on PTO unit. 	<ol style="list-style-type: none"> 1. Install correct shims on PTO unit.
Squealing or Whining - Remove and Disassemble Transmission ④	<ol style="list-style-type: none"> 1. Damaged bearings 2. End play of countershafts not within specifications. 	<ol style="list-style-type: none"> 1. Replace bearings. 2. Adjust countershaft end play withing specifications.

NOTES:

- ① Growling and humming are associated with the first stages of the condition. Grinding is associated with the severe stages of the condition.
- ② Hissing is associated with the first stages of the condition. Thumping and bumping are associated with the severe stages of the condition.
- ③ If the noise occurs when the clutch is engaged and stops when the clutch is disengaged, the the intermediate or center plate is the cause of the rattle.
- ④ Whining is a medium pitched noise. Squealing is a high pitched noise.

Troubleshooting Operating Conditions

CONDITION	CAUSE	REPAIR
Transmission Slips Out of the Selected Range - In-Vehicle Repair	<ol style="list-style-type: none"> 1. Loose air lines and fittings. 2. Obstructions in air lines. 3. Check operation of filter/regulator assembly. 4. Damaged O-ring on piston in range shift cylinder. ① 5. Loose or missing nut that fastens piston to shift shaft in range shift cylinder. ② 	<ol style="list-style-type: none"> 1. Tighten air lines and fittings. 2. Change routing or replace air lines. 3. Replace filter/regulator assembly if pressure at delivery port is not within 60-65 psi. 4. Replace O-ring on piston. 5. Tighten or replace nut.
Transmission Slips Out of the Selected Range - Remove and Disassemble Transmission	<ol style="list-style-type: none"> 1. Worn teeth in sliding clutch. 2. Bent or worn shift fork. 3. Worn collar on range shift fork. 	<ol style="list-style-type: none"> 1. Replace sliding clutch. 2. Replace shift fork. 3. Replace collar on range shift fork.
Transmission is Slow to Shift or Unable to Shift into the Selected Range - In-Vehicle Repair	<ol style="list-style-type: none"> 1. Loose or leaking air lines and fittings. 2. Obstructions in the air lines. 3. Filter/regulator assembly does not operate correctly. 4. Spool binding in slave valve. 5. Leakage at slave valve. ③ 6. Damaged piston and/or O-rings in piston housing. ④ 7. Worn or damaged neutral interlock pin. 8. Damaged shift knob/selector valve. 9. Damaged exhaust disc in slave valve. 	<ol style="list-style-type: none"> 1. Tighten or replace air lines or fittings. 2. Change routing or replace air lines. 3. Replace filter/regulator assembly if pressure at delivery port is not 60-65 psi. 4. Replace slave valve. 5. Replace slave valve. 6. Replace O-rings and/or piston in piston housing. 7. Replace pin. 8. Replace shift knob/selector valve. 9. Replace disc in slave valve.
Transmission is Slow to Shift or Unable to Shift into the Selected Range - Remove and Disassemble Transmission.	<ol style="list-style-type: none"> 1. Damaged output shaft. 2. Broken or missing synchronizer springs or pins. 3. Damaged synchronizer. 4. Bent or broken shift shaft in range cylinder. 5. Bent or broken shift fork in range cylinder. 6. Dirt between splines and gears. 7. Missing HI/LO fork pin and nut 	<ol style="list-style-type: none"> 1. Replace output shaft. 2. Replace synchronizer springs or synchronizer. 3. Replace synchronizer. 4. Replace shift shaft. 5. Replace shift fork. 6. Drain oil. Flush inside of housing. Fill to specified level with new fluid. 7. Replace HI/LO fork pin and nut.

NOTES:

- ① To check leakage at the range cylinder, first put the selector valve in the **LO** range. Disconnect the air line to the **HI** range port on the piston housing. Operate the vehicle to charge the air system. If air leaks are heard, the O-ring or the piston must be replaced.
- ② When the nut is loose or missing at the end of the shift shaft, the transmission will shift into the **HI** range but not into the **LO** range.
- ③ To check leakage at the slave valve, first put the selector valve in the **LO** range. Disconnect the air lines on the slave valve that goes to the **HI** range port of the piston housing. Operate the vehicle to charge the air system. If air is heard leaking inside the slave valve, the valve is the cause of the leak.
- ④ To check for leaks at the piston housing, disconnect the air lines at the piston housing. Apply air pressure to each port, one port at a time. If air leaks past the piston, the O-ring and/or the piston must be replaced. If the piston does not move, the shift shaft or the shift assembly is damaged.

Section 19

Troubleshooting

Troubleshooting Operating Conditions (Cont'd)

CONDITION	CAUSE	REPAIR
Transmission Slips Out of the Selected Gear - In-Vehicle Repair.	<ol style="list-style-type: none"> 1. Incorrect clutch use. 2. Linkage binding or does not move freely. 3. Clutch out-of-adjustment. 4. Remote shift linkage out-of-adjustment. 5. Loose or damaged engine and/or cab mounts. 6. Incorrect driveline angles. 7. Weak or broken detent spring in top cover assembly. 	<ol style="list-style-type: none"> 1. Make sure driver uses clutch correctly. 2. Lubricate, repair or replace linkage. 3. Adjust clutch. Make sure clutch engages and releases correctly. 4. Adjust remote shift linkage. 5. Tighten fasteners of loose mounts to specified torque. Replace damaged mounts. 6. Adjust driveline angles. 7. Replace detent spring in top cover assembly.
Transmission Slips Out of the Selected Gear - Remove and Disassemble Transmission	<ol style="list-style-type: none"> 1. Worn pads on shift fork. 2. Worn teeth in sliding clutch. 3. Worn fork slot on sliding clutch. 4. Broken key on mainshaft. 5. Twisted mainshaft. 	<ol style="list-style-type: none"> 1. Replace shift fork. 2. Replace sliding clutch. 3. Replace sliding clutch. 4. Replace key and/or mainshaft. 5. Replace mainshaft.
Transmission Is Hard to Shift or Unable to Shift Into the Selected Gear - In-Vehicle Repair	<ol style="list-style-type: none"> 1. Incorrect vehicle operation. 2. Clutch out-of-adjustment. 3. Remote shift linkage binding or unable to move. 4. Loose and/or damaged cab and/or engine mounts. 5. Detent spring too strong or broken. 	<ol style="list-style-type: none"> 1. Make sure driver operates vehicle correctly. 2. Adjust clutch. Make sure clutch engages and releases correctly. 3. Lubricate, repair or replace remote shift linkage. 4. Tighten fasteners of loose mounts to specified torque. Replace damaged mounts. 5. Replace detent spring.
Transmission Is Hard to Shift or Unable to Shift into the Selected Gear - Remove and Disassemble Transmission	<ol style="list-style-type: none"> 1. Bent shift shaft in top cover assembly. 2. Burr on shift shaft in top cover assembly. 3. Cracked top cover assembly. 4. Twisted mainshaft. 5. Broken key on mainshaft. 6. Broken or bent shift fork on sliding clutch. 	<ol style="list-style-type: none"> 1. Replace shift shaft. 2. Replace shift shaft. 3. Replace top cover assembly. 4. Replace mainshaft. 5. Replace key and/or mainshaft. 6. Replace fork.
Transmission Grinds on Initial Engagement - In-Vehicle Repair.	<ol style="list-style-type: none"> 1. Driver does not operate vehicle correctly. 2. Clutch out-of-adjustment. 3. Worn, damaged or missing clutch brake. 4. Clutch and/or remote shift housing linkage binding or unable to move 5. Worn bushings in side of clutch housing. 	<ol style="list-style-type: none"> 1. Make sure driver operates vehicle correctly. 2. Adjust clutch. Make sure clutch engages and releases correctly. 3. Replace clutch brake. Make sure clutch engages and releases correctly. 4. Lubricate, repair or replace linkage. 5. Replace bushings in the clutch housing.

Troubleshooting Operating Conditions (Cont'd)

CONDITION	CAUSE	REPAIR
Shift Lever Locks or Sticks In Gear - In-Vehicle Repair.	<ol style="list-style-type: none"> 1. Remote shift linkage out-of-adjustment. 2. Clutch linkage needs adjustment. 3. Linkage binding or unable to move. 4. Loose or damaged cab and/or engine mounts. 5. Damaged balls or rails in top cover assembly. 	<ol style="list-style-type: none"> 1. Adjust remote shift linkage. 2. Adjust clutch linkage. 3. Lubricate, repair or replace linkage. 4. Tighten fasteners of loose mounts to specified torque. Replace damaged mounts. 5. Replace balls or rails.
Shift Lever Locks or Sticks In Gear - Remove and Disassemble Transmission	<ol style="list-style-type: none"> 1. Bent shift fork in top cover. 2. Damaged shift shaft in top cover. 3. Damaged mainshaft. 	<ol style="list-style-type: none"> 1. Replace shift fork 2. Replace shift shaft. 3. Replace mainshaft.
Transmission Overheats - In-Vehicle ⑤ ⑥	<ol style="list-style-type: none"> 1. Incorrect oil level. 2. Incorrect oil. 3. Damaged temperature gauge. ⑦ 	<ol style="list-style-type: none"> 1. Fill to specified level. 2. Drain oil. Use specified oil. 3. Replace temperature gauge.
Transmission Does Not Operate - Remove and Disassemble Transmission	<ol style="list-style-type: none"> 1. Missing or damaged interlock ball in top cover. 2. Free running gears are locked. 3. Mismatched gear sets. 4. Timing marks on gears not aligned. 5. Broken shafts. 	<ol style="list-style-type: none"> 1. Replace interlock ball in top cover. 2. Replace gears. 3. Install correct gear sets. 4. Align timing marks on gears. 5. Replace shafts.

NOTES:

- ⑤ If a noise is present along with the overheating condition, see the "Troubleshooting Noise" chart to identify and service the noise.
- ⑥ If the oil is at the specified level and the specified oil is used, but the transmission overheats and the oil smells burnt, the transmission must be disassembled and inspected.
- ⑦ If the oil does not have a burnt smell and the temperature gauge indicates overheating, remove and replace the gauge.

Section 20 Specifications

Transmission Oil Capacities *

Transmission Model	U.S Pints	Liters
RM9-115A	20.0	9.5
RM9-125A	20.0	9.5
RM9-135A	20.5	9.7
RM9-145A	20.5	9.7
RM9-155A	20.5	9.7
RMO9-125A	20.0	9.5
RMO9-135A	20.5	9.7
RMO9-145A	20.5	9.7
RMX9-125A	20.0	9.5
RMX9-135A	20.5	9.7
RMX9-145A	20.5	9.7
RMO9-115B	20.0	9.5
RMO9-125B	20.0	9.5
RMO9-135B	20.5	9.7
RMO9-145B	20.5	9.7
RMX9-115B	20.0	9.5
RMX9-125B	20.0	9.5

Transmission Model	U.S Pints	Liters
RMX9-135B	20.5	9.7
RMX9-145B	20.5	9.7
RMX9-155B	20.5	9.7
RMX9-115R	20.0	9.5
RMX9-125R	20.0	9.5
RMX9-135R	20.5	9.7
RMX9-145R	20.5	9.7
RM10-115A	20.0	9.5
RM10-125A	20.0	9.5
RM10-135A	20.5	9.7
RM10-145A	20.5	9.7
RMX10-115A	20.0	9.5
RMX10-125A	20.0	9.5
RMX10-135A	20.5	9.7
RMX10-145A	20.5	9.7
RMX10-155A	20.5	9.7
RMX-10-165A	20.5	9.7
RMO-13-145A	22.0	10.4

*Oil capacities are approximate. Fill the transmission to the bottom of the fill plug hole. On transmissions equipped with an oil pump and/or oil cooler, operate the engine with the transmission in **NEUTRAL** and the clutch engaged for five minutes after the initial fill and check the oil level again.

Transmission Oil Specifications

Lubricant Type	Grade (SAE)	Outside Temperature
Full-Synthetic Oil Meritor Specification 0-81*	50	All
Heavy Duty Engine Oil, A.P.I.-CD, -CE, -SF or -SG (Current A.P.I. Designations Acceptable) * MIL-2104B, C, D or E *	50 40 30	Above 10°F (-12° C) Above 10°F (-12° C) Above -15°F (-26° C)
Mineral Oil with Rust and Oxidation Inhibitor, A.P.I.-GL-1 *	90 80	Above 10°F (-12° C) Above -15°F (-26° C)

* Use only the specified type of single weight oils. Do not use multi-viscosity and EP (Extreme Pressure) GL-5 gear oils. Multi-viscosity and EP gear oils may damage components. The use of multi-viscosity or EP gear oils void the warranty.

Fastener Torque Locations- Nine-Speed and Ten-Speed
Transmissions

TOP VIEW

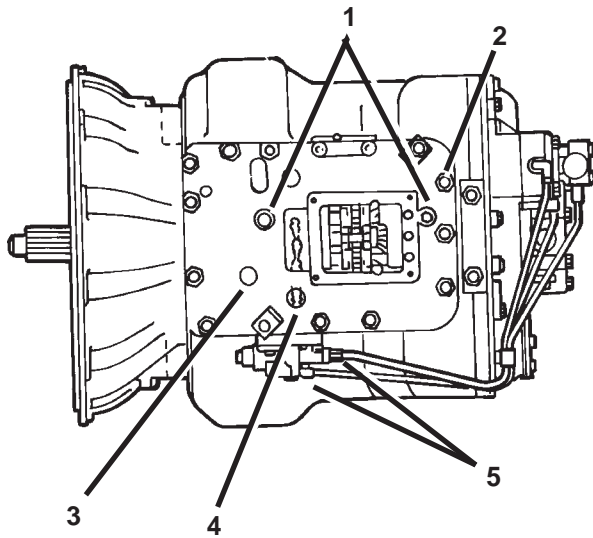

SIDE VIEW

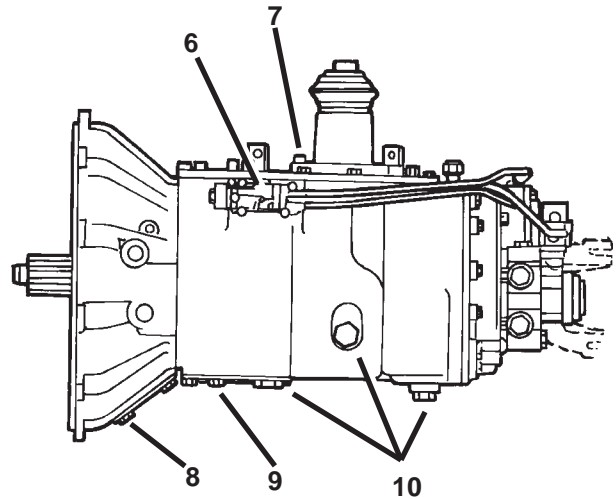

FRONT VIEW
WITH CLUTCH HOUSING

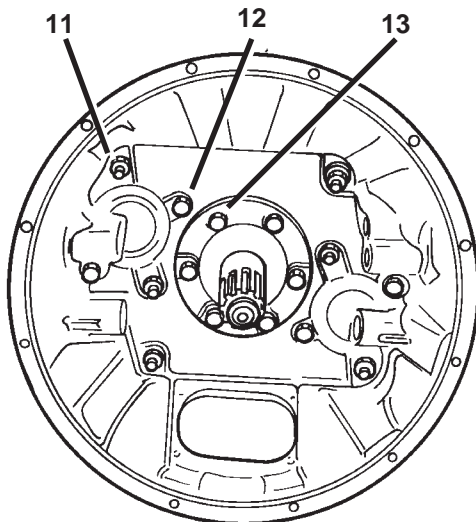

FRONT VIEW
WITHOUT CLUTCH HOUSING
DESIGN LEVEL 2

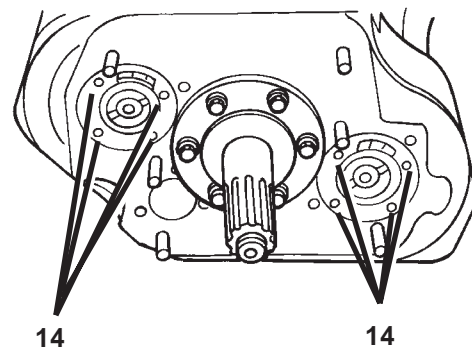

Section 20 Specifications

Fastener Torque Locations- Nine-Speed and Ten-Speed Transmissions (Continued)

REAR VIEW
WITH AUXILIARY
COVER

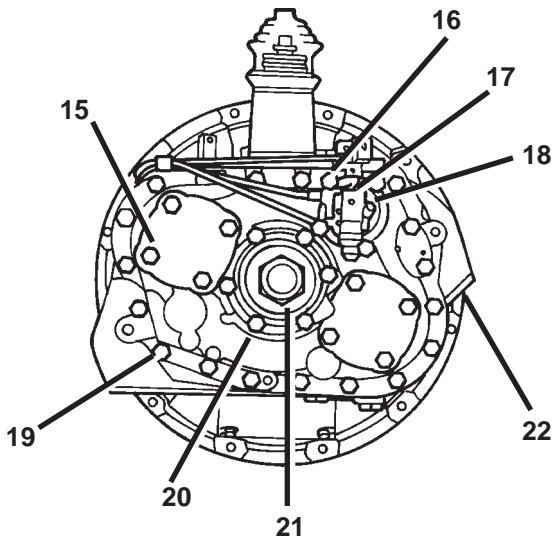

REAR VIEW
WITHOUT AUXILIARY COVER
DESIGN LEVEL 2
WITH ROUND RETAINER

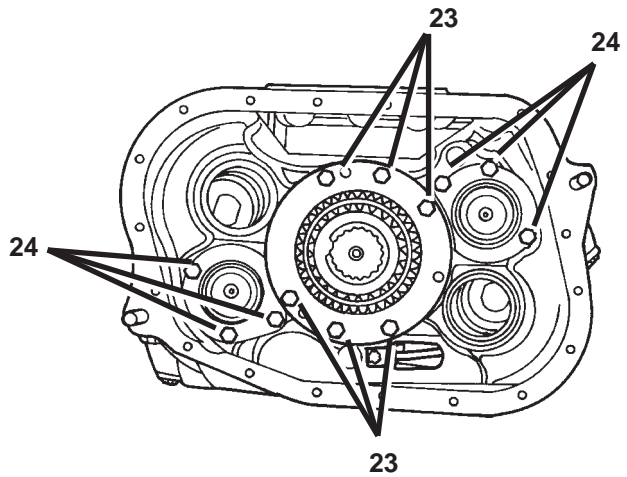

REAR VIEW
WITHOUT AUXILIARY COVER
DESIGN LEVEL 2
WITH TWO-PIECE RETAINER

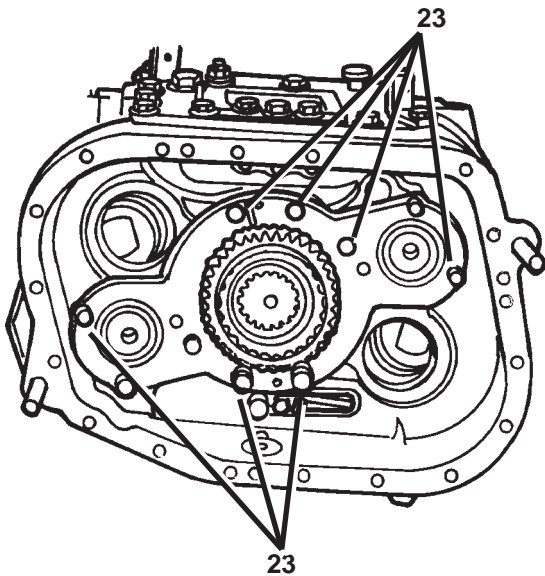

TOP COVER
STANDARD X-BAR SHOWN

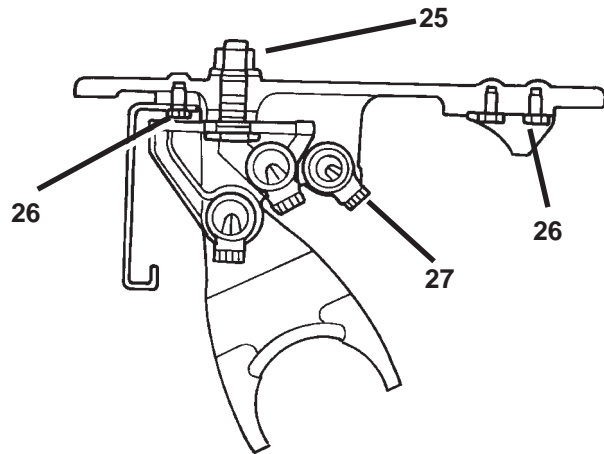

Fastener Torque Locations- Nine-Speed and Ten-Speed
Transmissions (Continued)

MAIN CASE
REVERSE IDLER GEAR

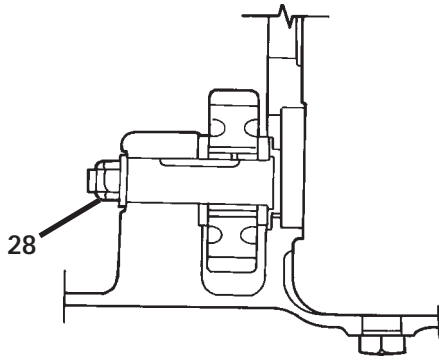

MAIN CASE
OIL PUMP

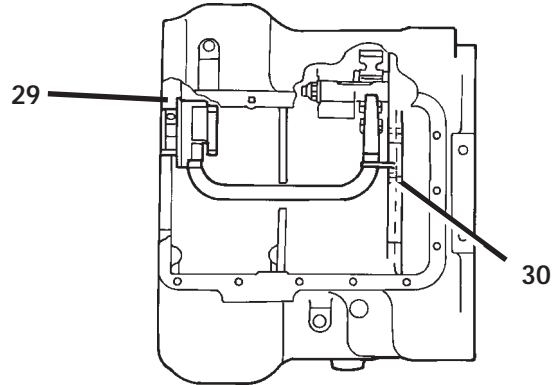

AUXILIARY CASE

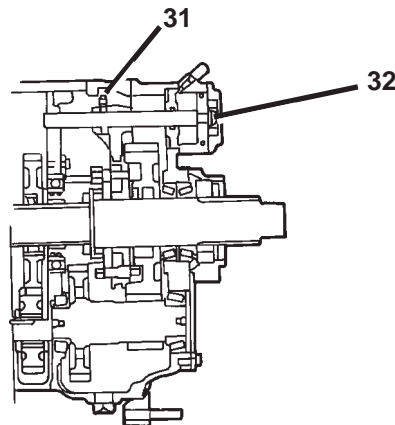

REMOTE CONTROL HOUSING

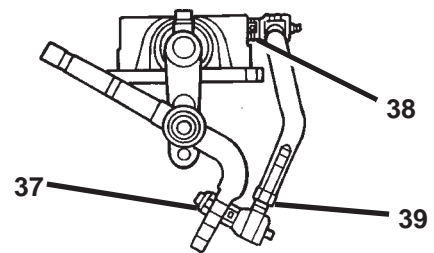
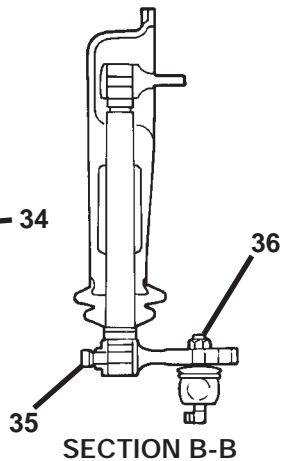
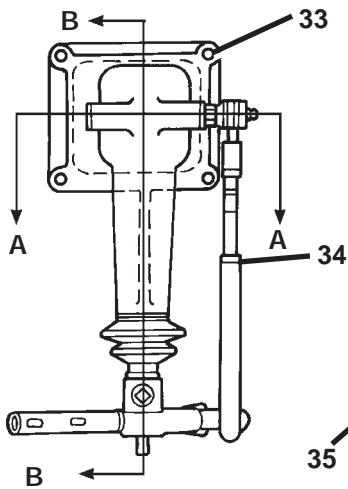

SIDE VIEW

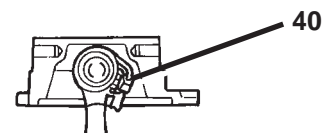

SECTION A-A

Section 20

Specifications

Fastener Torque Chart - Nine-Speed and Ten-Speed Transmissions

Item	Description	Size (Inch)	Torque Range	
			Lb-Ft	N.m
1	Back-Up Lamp Switch to Top Cover Housing	9/16-18 UNF	35-50	47-67
2	Top Cover Housing to Main Case Capscrew ①	3/8-16 UNC x 1-1/4	25-35	34-47
3	Neutral Safety Switch to Top Cover Housing	3/4- 16 UNF	35-50	47-67
4	Breather Vent	3/8-18 NPT	15-20	21-27
5	Slave Valve Air Fittings	1/8 NPT	15-20	21-27
6	Slave Valve to Transmission Case Capscrew ①	1/4-20 UNC 1-1/2	85-115 lb-in	10-12
7	Shift Tower to Top Cover Housing ①	3/8-16 UNC x 1-1/4	35-45	47-60
8	Inspection Cover to Clutch Housing Capscrew	3/8-16 UNC x 5/8	25-35	34-47
9	PTO Cover to Case Capscrew – 8-Hole ①	7/16-14 UNC x 3/4	35-45	47-61
10	Drain and Fill Plugs to Main Case	1-1/16 -12 UN	35-50	47-67
11	Clutch Housing to Main Case Nut ①	5/8-18 UNF	150-190	204-257
12	Clutch Housing to Main Case Capscrew ①	1/2-13 UNC x 1-1/2 1/2-13 UNC x 3-1/2	65-85 65-85	89-115 89-115
13	Input Bearing Retainer to Main Case Capscrew ①	3/8-16 UNC x 1-1/4	25-35	34-47
14	Front Cup Retainer to Main Case Allen-head Capscrew ①	-----	120-140 in-lbs	14-15
15	Countershaft Cover to Auxiliary Case Capscrew ①	3/8-16 UNC x 1	25-35	34-47
16	Range Cylinder Cover to Auxiliary Case Capscrew ①	3/8-16 UNC x 2-3/4	35-45	47-61
17	Air Filter/Regulator End Cap	-----	20-25 lb-in	2.3-2.8
18	Air Filter/Regulator to Auxiliary Case Capscrew ①	1/4-20UNC x 2	85-115 lb-in	10-12
19	Auxiliary Cover to Main Case Capscrew ①	3/8-16 UNC x 1-1/2	35-45	47-61
20	Output Bearing Retainer to Main Case Capscrew ①	3/8-16 UNC x 3	35-45	47-61
21	Yoke to Output Shaft Nut ③	2-16 UN	450-500	610-677
22	PTO Cover to Case Capscrew – 6-Hole ①	3/8-16 UNC x 3/4	35-45	47-61
23	Auxiliary Drive Gear to Main Case Capscrew ①	3/8-16 x 1	35-45	47-61
24	Rear Bearing Retainer to Main Case Capscrew ①	3/8-16 UNC x 1	25-35	34-47
25	Rocking Lever Assembly Pin guide to Top Cover Housing Nut	1/2-20 UNF	35-45	47-61
26	Oil Scoop to Top Cover Housing Capscrew ①	1/4-20 x 1/2 UNC	10-13	13-17
27	Shift Fork to Shift Rail Set Screw ②	7/16-20 UNF	35-45	47-61
28	Reverse Idler Gear to Shaft Nut ①	5/8-18 UNF	75-100	101-135
29	Oil Pump to Main Case Capscrew ①	1/4-20 UNC x 1-1/2	7-10	10-13

See NOTES on the following page.

Fastener Torque Chart - Nine-Speed and Ten-Speed Transmissions Chart (Continued)

Item	Description	Size (Inch)	Torque Range	
			Lb-Ft	N.m
30	Oil Pump Pick-up Tube Bracket to Transmission Case Capscrew ①	3/8-16 UNC x 1/2	5-10	7-13
31	HI/LO Shift Fork to HI/LO Shift Shaft Shoulder Bolt	5/16-18 UNC	8-12	11-16
32	Piston to Shift Shaft Nut ①	7/16-20 UNF	35-50	48-67
33	Remote Control Housing to Top Cover Capscrew	-----	35-45	47-61
34	Remote Control Housing Adjusting Rod Jam Nut	1/2-13 UNC	35-50	47-67
35	Remote Control Housing Outer Shift Lever Set Screw	7/16-14 UNC	32-40	44-54
36	Remote Control Housing Outer Shift to Linkage Nut	7/16-20 UNF	12-18	17-24
37	Remote Control Housing Adjusting Rod to Linkage Nut	1/2-13 UNC	65-85	89-115
38	Remote Control Housing Socket	1/2-13 UNC	35-50	47-67
39	Remote Control Housing Adjusting Rod to Linkage Nut	1/2-20 UNF	60-75	82-101
40	Remote Control Housing Inner Shift Lever Set Screw	7/16-14 UNC	32-40	44-54

NOTES:

- ① On fasteners with threads 1/4 inch (7mm) or smaller, put Loctite ® 222 (Meritor Part Number 2297-B-6112) or equivalent on the threads. On fasteners with threads greater than 1/4 inch (7mm) threads or smaller, put Loctite ® 242 (Meritor Part Number 2297-V-2430) or equivalent on the threads. Put a new application of Loctite ® or equivalent if any of the following occur.
 - a. A new fastener is installed.
 - b. The sealant is removed from the threads.
 - c. The fastener is removed the third time from the transmission.
- ② Requires Loctite ® 242 (Meritor Part Number 2297-V-2430) or equivalent and lockwire. After the capscrews are tightened to the specified torque, do not loosen or tighten the capscrews. If the capscrews are loosened or tightened, the capscrews must be removed, cleaned and new sealant applied or the capscrews may loosen during operation.
When installing lockwire, do the following:
 - a. Trim excess wire to a 1/4 inch (6 mm) length.
 - b. Bend the wire towards the capscrew.
 - c. Twist the wire at least once between parts.
 - d. On the 1-2 sleeve, the wire can be wrapped around the shaft.
- ③ Do not tighten more than the specified torque or the output bearing may be damaged.

Section 20 Specifications

Fastener Torque Locations- Thirteen-Speed Transmissions

TOP VIEW

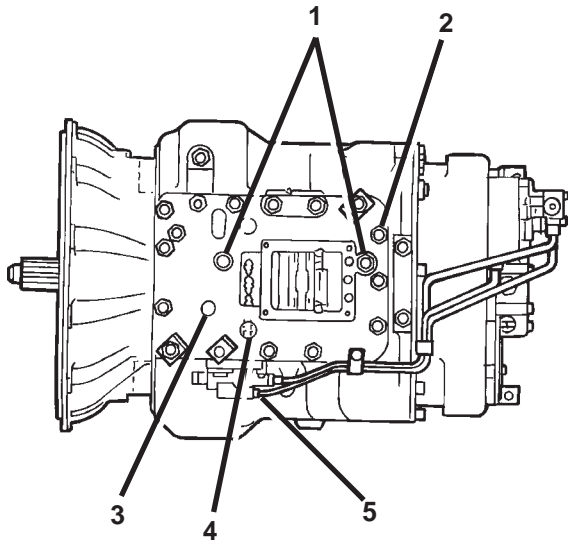

SIDE VIEW

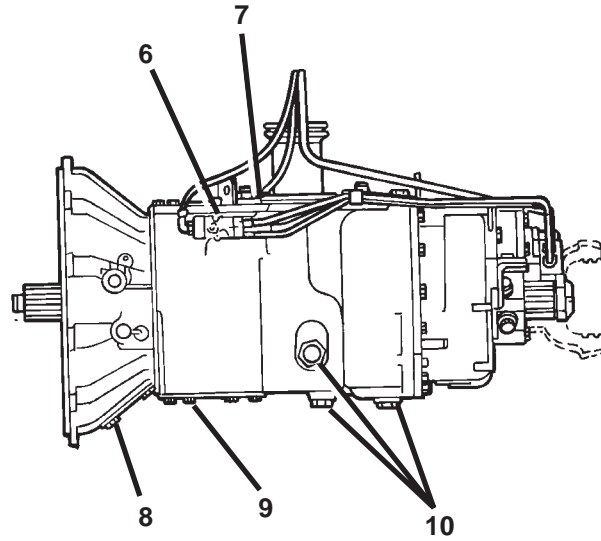

FRONT VIEW
WITH CLUTCH HOUSING

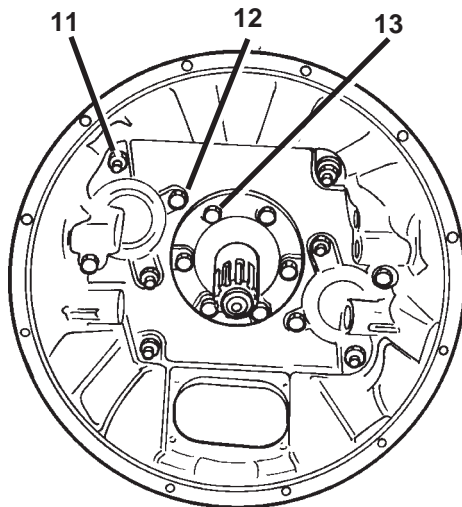

FRONT VIEW
WITHOUT CLUTCH HOUSING
DESIGN LEVEL 2

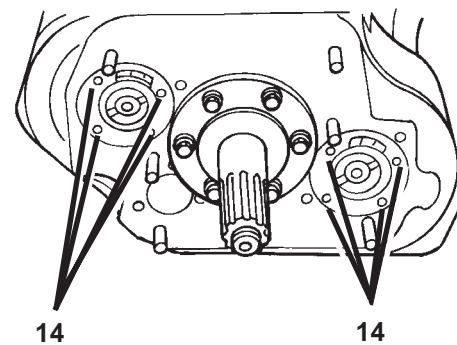

Fastener Torque Locations- Thirteen-Speed Transmissions (Continued)

REAR VIEW
WITH AUXILIARY COVER

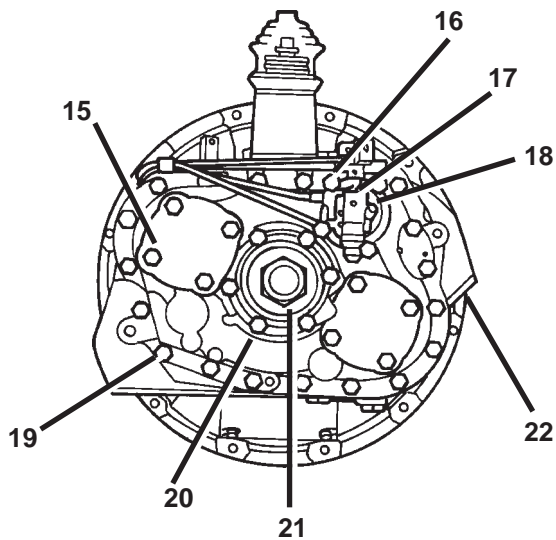

REAR VIEW
WITHOUT AUXILIARY COVER
DESIGN LEVEL 2
WITH ROUND RETAINER

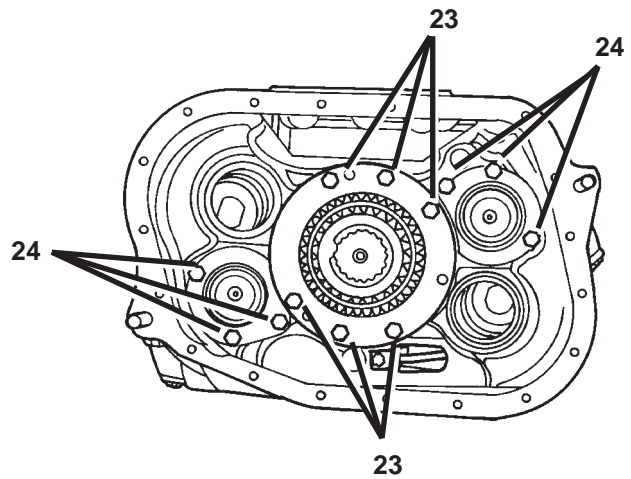

REAR VIEW
WITHOUT AUXILIARY COVER
DESIGN LEVEL 2
WITH TWO-PIECE RETAINER

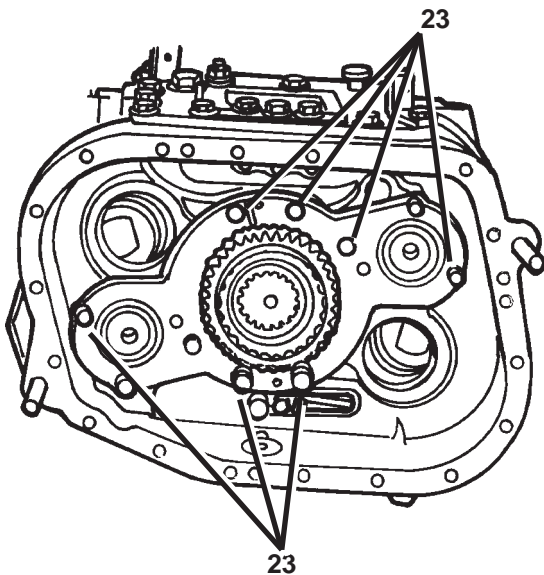

TOP COVER
STANDARD X-BAR
SHOWN

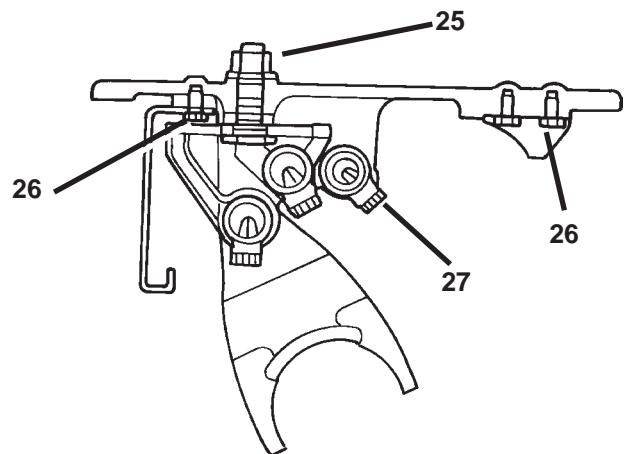

Section 20 Specifications

Fastener Torque Locations- Thirteen-Speed Transmissions (Continued)

MAIN CASE
REVERSE IDLER GEAR

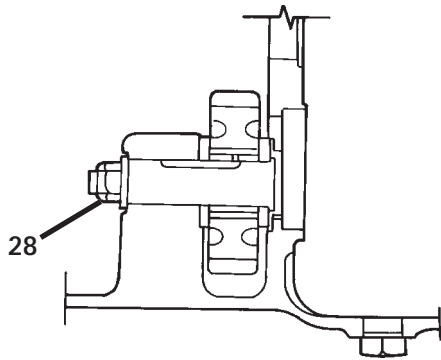

MAIN CASE
OIL PUMP

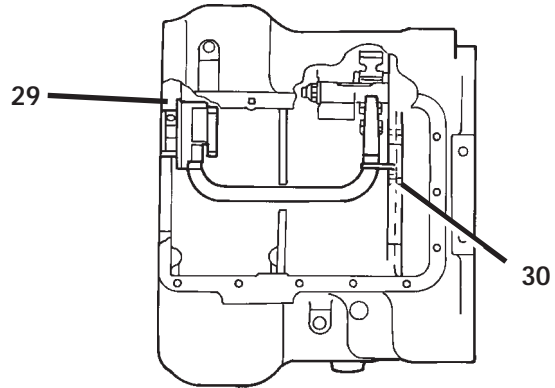

AUXILIARY CASE

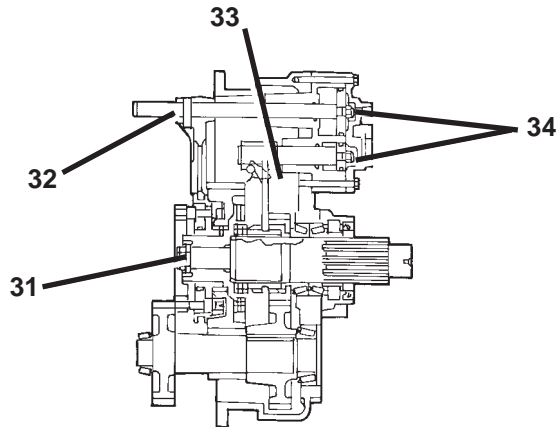

REMOTE CONTROL HOUSING

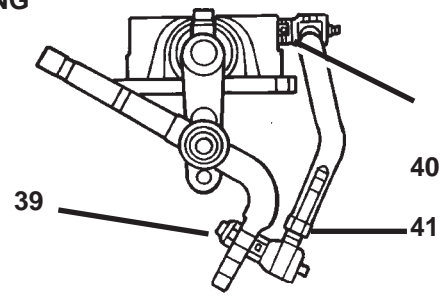
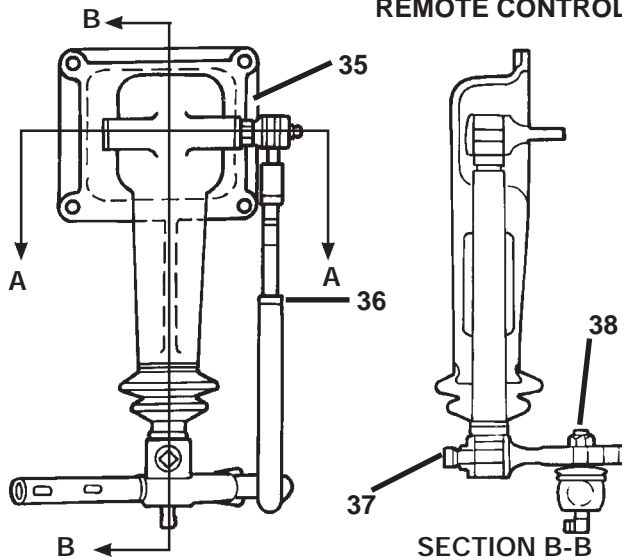

SIDE VIEW

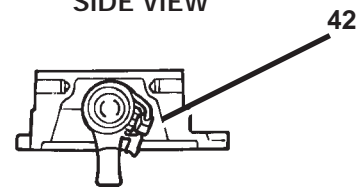

SECTION A-A

Section 20 Specifications

Fastener Torque Chart- Thirteen-Speed Transmission

Item	Description	Size (Inch)	Torque Range	
			Lb-Ft	N.m
1	Back-Up Lamp Switch to Top Cover Housing	9/16-18 UNF	35-50	47-67
2	Top Cover Housing to Main Case Capscrew ①	3/8-16 UNC x 1-1/4	25-35	34-47
3	Neutral Safety Switch to Top Cover Housing	3/4- 16 UNF	35-50	47-67
4	Breather Vent	3/8-18 NPT	15-20	21-27
5	Slave Valve Air Fittings	1/8 NPT	15-20	21-27
6	Slave Valve to Main Case Capscrew ①	1/4-20 UNC x 1-1/2	85-115 lb-in	10-12
7	Shift Tower to Top Cover Housing ①	3/8-16 UNC x 1-1/4	25-35	34-47
8	Inspection Cover to Clutch Housing Capscrew	3/8-16 UNC x 5/8	25-35	34-47
9	PTO Cover to Case Capscrew – 8-Hole ①	7/16-14 UNC x 3/4	35-45	47-61
10	Drain and Fill Plugs to Main Case	1-1/16-12 UN	35-50	47-67
11	Clutch Housing to Main Case Nut ①	5/8-18 UNF	150-190	204-257
12	Clutch Housing to Main Case Capscrew ①	1/2-13 UNC x 1-1/2 1/2-13 UNC x 3-1/2	65-85 65-85	89-115 89-115
13	Input Bearing Retainer to Main Case Capscrew ①	3/8-16 UNC x 1-1/4	25-35	34-47
14	Front Cup Retainer to Main Case Allen-head Capscrew ①	-----	120-140 in-lbs	14-15
15	Countershaft Cover to Auxiliary Case Capscrew ①	3/8-16 UNC x 1	25-35	34-47
16	Piston Housing to Auxiliary Case Capscrew ①	3/8-16 UNC x 3	35-45	47-61
17	Air Filter/Regulator End Cap	-----	20-25 lb-in	2.3-2.8
18	Filter and Regulator to Auxiliary Case Capscrew	1/4-20UNC x 3/4	85-115 lb-in	10-12
19	Auxiliary Cover to Main Case Capscrew ①	3/8-16 UNC x 1-1/2	35-45	47-61
20	Output Bearing Retainer to Main Case Capscrew ①	3/8-16 UNC x 3	35-45	47-61
21	Yoke to Output Shaft Nut ③	2-16 UN	450-500	610-677
22	PTO Cover to Case Capscrew – 6-Hole ①	3/8-16 UNC x 3/4	35-45	47-61
23	Auxiliary Drive Gear to Main Case Capscrew ①	3/8-16 x 1	35-45	47-61
24	Rear Bearing Retainer to Main Case Capscrew ①	3/8-16 UNC x 1	25-35	34-47
25	Rocking Lever Assembly Pin guide to Top Cover Housing Nut	1/2-20 UNF	35-45	47-61
26	Oil Scoop to Top Cover Housing Capscrew ①	1/4-20 x 1/2 UNC	10-13	13-17
27	Shift Fork to Shift Rail Set Screw ②	7/16-20 UNF	35-45	47-61
28	Reverse Idler Gear to Shaft Nut ①	5/8-18 UNF	75-100	101-135
29	Oil Pump to Main Case Capscrew ①	1/4-20 UNC x 1-1/2	7-10	10-13
30	Oil Pump Pick-up Tube Bracket to Transmission Case Capscrew ①	3/8-16 UNC x 1/2	5-10	7-13

See NOTES on the following page.

Section 20

Specifications

Fastener Torque Chart - Thirteen-Speed Transmission (Continued)

Item	Description	Size (Inch)	Torque Range	
			Lb-Ft	N.m
31	Output Shaft to Synchronizer Nut ①	7/8-14 UNF	220-260	299-352
32	HI/LO Shift Fork to HI/LO Shift Shaft Shoulder Bolt	5/16-18 UNC	8-12	11-16
33	Splitter Fork to Shaft Capscrew ①	7/16-20 UNF	35-45	47-61
34	Piston to Shift Shaft Nut ①	7/16-20 UNF	30-45	41-60
35	Remote Control Housing to Top Cover Capscrew	-----	35-45	47-61
36	Remote Control Housing Adjusting Rod Jam Nut	1/2-13 UNC	35-50	47-67
37	Remote Control Housing Outer Shift Lever Set Screw	7/16-14 UNC	32-40	44-54
38	Remote Control Housing Outer Shift to Linkage Nut	7/16-20 UNF	12-18	17-24
39	Remote Control Housing Adjusting Rod to Linkage Nut	1/2-13 UNC	65-85	89-115
40	Remote Control Housing Socket	1/2-13 UNC	35-50	47-67
41	Remote Control Housing Adjusting Rod to Linkage Nut	1/2-20 UNF	60-75	82-101
42	Remote Control Housing Inner Shift Lever Set Screw	7/16-14 UNC	32-40	44-54

NOTES:

- ① On fasteners with threads 1/4 inch (7mm) or smaller, put Loctite ® 222 (Meritor Part Number 2297-B-6112) or equivalent on the threads. On fasteners with threads greater than 1/4 inch (7mm) threads or smaller, put Loctite ® 242 (Meritor Part Number 2297-V-2430) or equivalent on the threads. Put a new application of Loctite ® or equivalent if any of the following occur.
- A new fastener is installed.
 - The sealant is removed from the threads.
 - The fastener is removed the third time from the transmission.
- ② Requires Loctite ® 242 (Meritor Part Number 2297-V-2430) or equivalent and lockwire. After the capscrews are tightened to the specified torque, do not loosen or tighten the capscrews. If the capscrews are loosened or tightened, the capscrews must be removed, cleaned and new sealant applied or the capscrews may loosen during operation.
- When installing lockwire, do the following:
- Trim excess wire to a 1/4 inch (6 mm) length.
 - Bend the wire towards the capscrew.
 - Twist the wire at least once between parts.
 - On the 1-2 sleeve, the wire can be wrapped around the shaft.
- ③ Do not tighten more than the specified torque or the output bearing may be damaged.

Air Line Locations - Nine-Speed and Ten-Speed Transmissions

MAIN VIEW

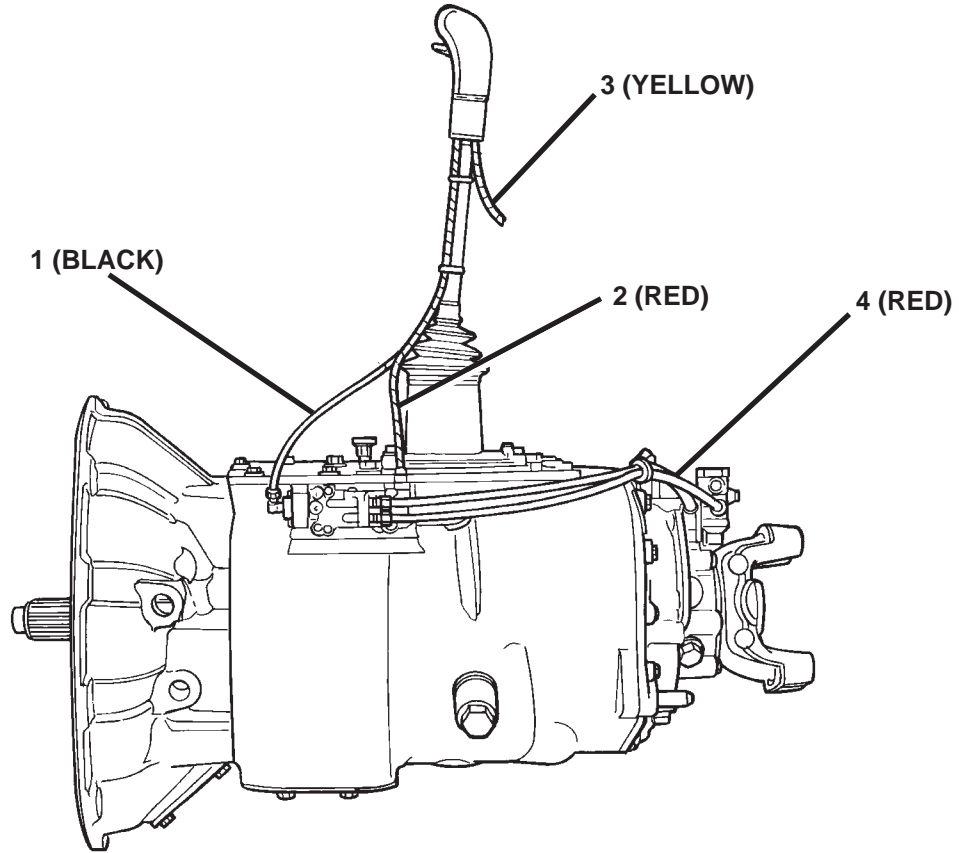

SELECTOR VALVE

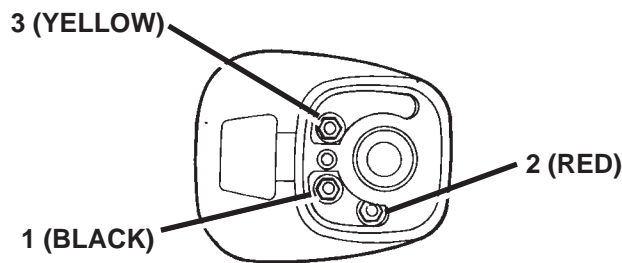

FILTER/REGULATOR ASSEMBLY AND RANGE CYLINDER

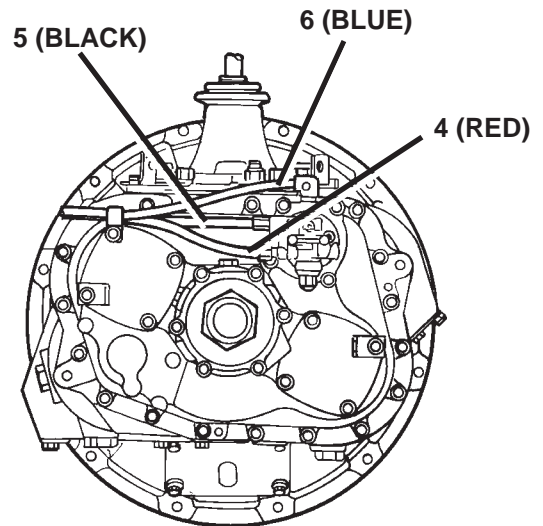

SLAVE VALVE

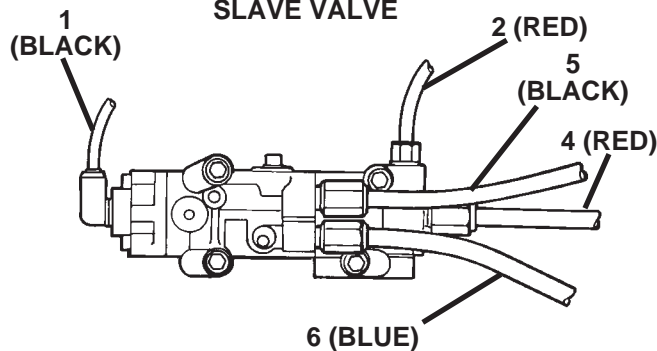

Section 20

Specifications

Air Line Identification Chart - Nine-Speed and Ten-Speed Transmissions

Item	Description	Hose Color	Hose Outer Diameter	Specification
1	Pilot Fitting on Selector Valve to Pilot Fitting on Slave Valve	Black ①	5/32 inch or 1/8 inch ①	SAE J844 Type A
2	Pilot Supply Fitting on Selector Valve to Pilot Supply Fitting on Slave Valve	Red ①	5/32 inch or 1/8 inch ①	SAE J844 Type A
3	Exhaust Fitting on Selector Valve	Yellow	5/32 inch	SAE J844 Type A
4	Supply Fitting on Filter/Regulator to Supply Fitting on Slave Valve	Red	5/16 inch ②	SAE J844 Type A
5	LO Range Port on Slave Valve to LO Range Port on Range Cylinder	Black	5/16 inch ②	SAE J844 Type A
6	HI Range Port on Slave Valve to HI Range Port on Range Cylinder	Blue	5/16 inch ②	SAE J844 Type A

NOTES:

- ① Color or hose diameter may vary by vehicle manufacturer.
- ② If 1/4 inch air lines and fittings are used, replace the lines and fittings with 5/16 inch air lines and fittings.

Air Line Locations - Thirteen-Speed Transmissions

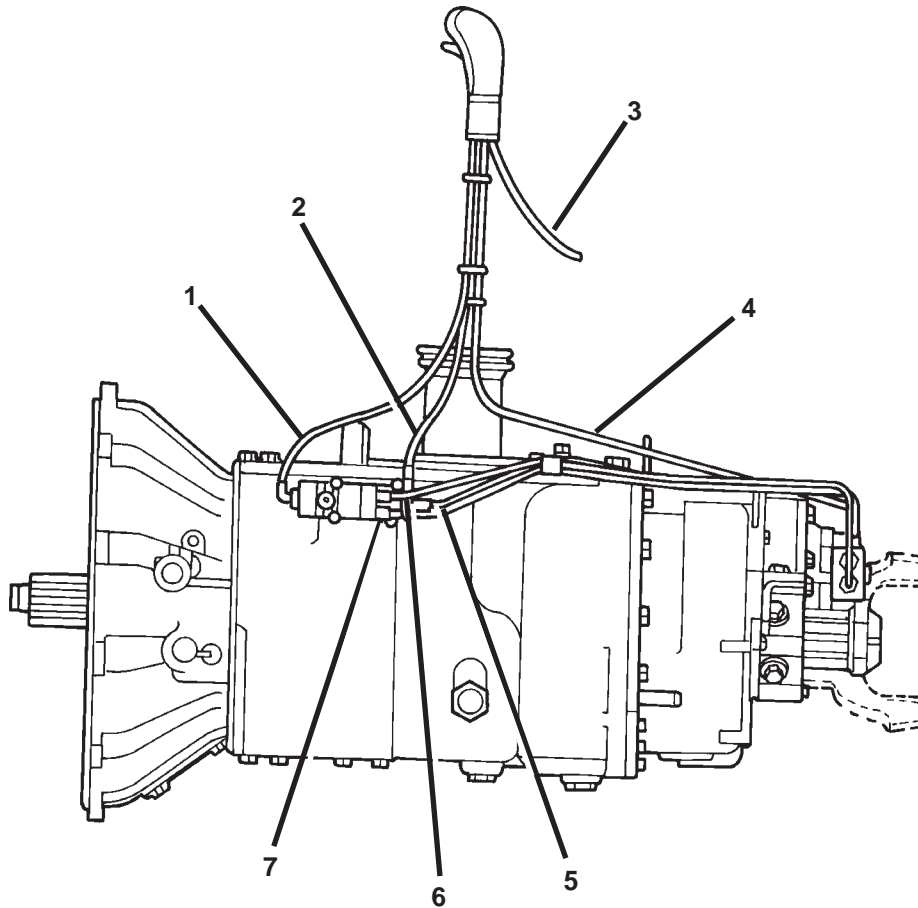

SELECTOR VALVE

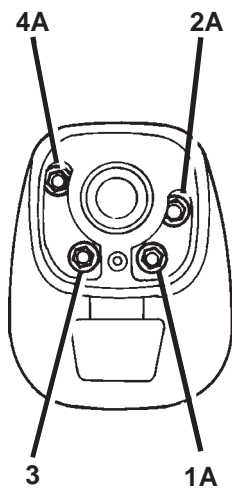

FILTER AND REGULATOR ASSEMBLY PISTON HOUSING

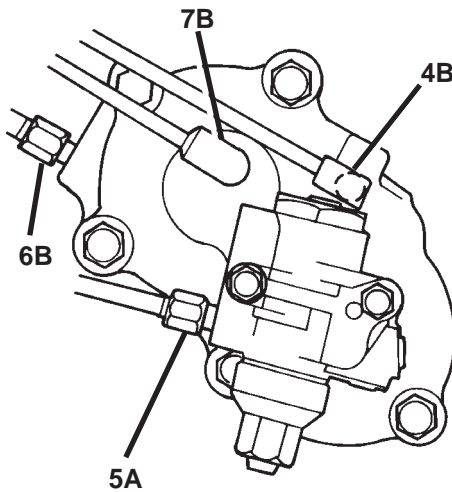

SLAVE VALVE

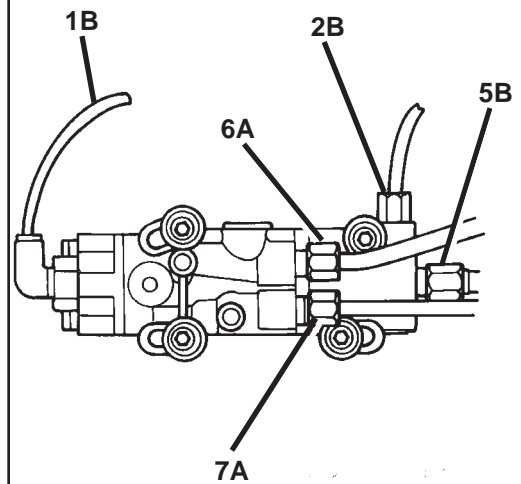

Section 20

Specifications

Air Tube Identification Chart - Thirteen-Speed Transmissions

Item	Description	Tube Color	Tube Outer Diameter	Specification
1	Pilot Fitting on Selector Valve (1A) to Pilot Fitting on Slave Valve (1B)	*	5/32 inch or 1/8 inch	SAE J844 Type A
2	Pilot Supply Fitting on Selector Valve (2A) to Pilot Supply Fitting on Slave Valve (2B)	*	5/32 inch or 1/8 inch	SAE J844 Type A
3	Exhaust Fitting on Selector Valve	*	5/32 inch or 1/8 inch	SAE J844 Type A
4	Splitter Fitting on Selector Valve (4A) to Splitter Fitting on Piston Housing Cover (4B)	*	5/32 inch or 1/8 inch	SAE J844 Type A
5	Supply Fitting on Filter and Regulator (5A) to Supply Fitting on Slave Valve (5B)	*	1/4 inch	SAE J844 Type A
6	LO Range Port on Slave Valve (6A) to LO Range Port on Piston Housing (6B)	*	1/4 inch	SAE J844 Type A
7	HI Range Port on Slave Valve (7A) to HI Range Port on Piston Housing Cover (7B)	*	1/4 inch	SAE J844 Type A

* See the specifications of the manufacturer of the vehicle for the color of the tube.

Holding Cover Template
3305-W-1141

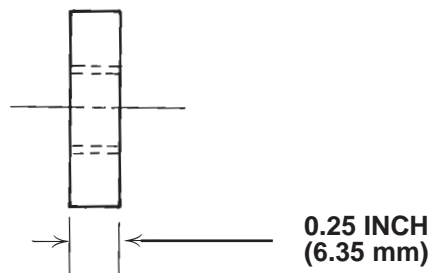
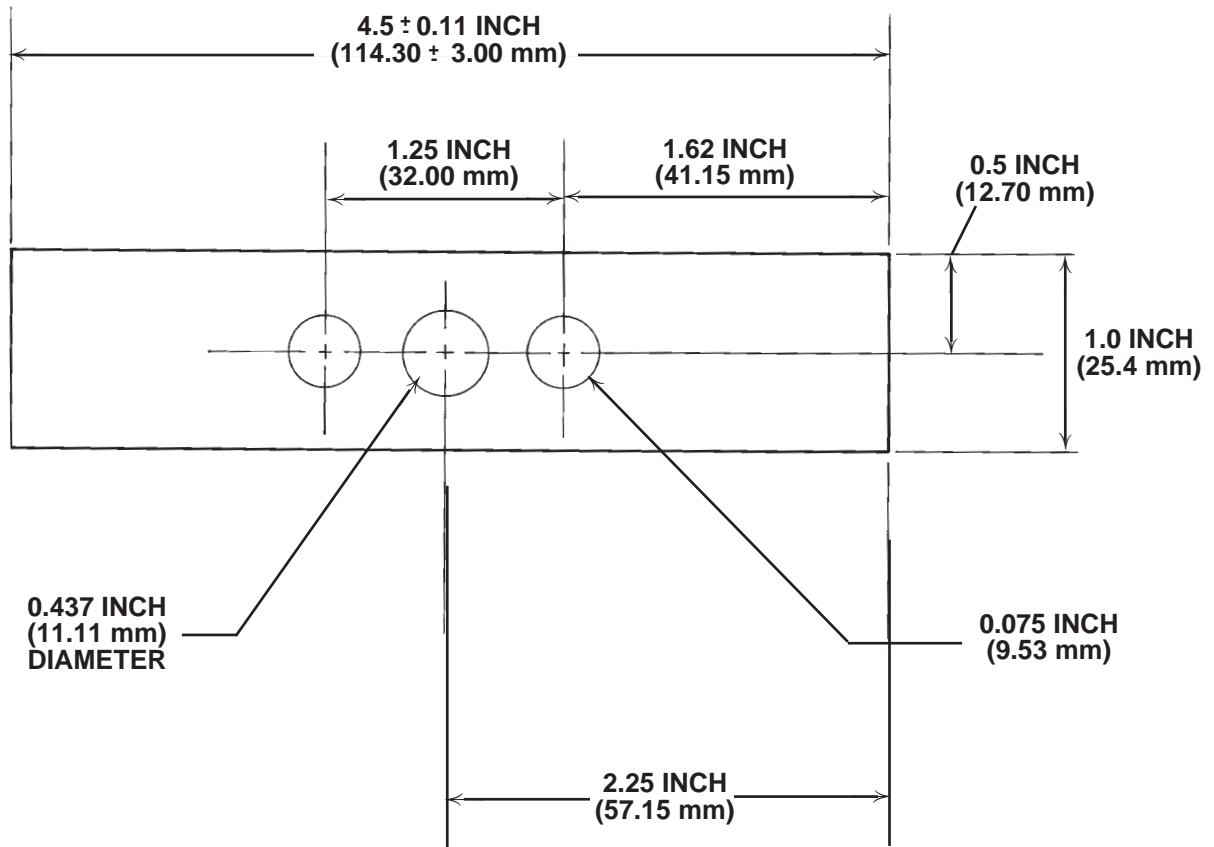

Section 20

Specifications

Special Tools

Tool Description	Tool Number	Tool Manufacturer
Bearing Puller Tool	3256-W-1037 J-41086	Meritor ① Kent-Moore ②
Bearing Cup Seating Tool	3256-T-1034	Meritor ①
Bearing Cup Seating Tool	J-41085	Kent-Moore ②
Bearing Service Set (Input Shaft Removal)	OTC-7070	Owatonna ③
Countershaft Bearing Pusher Tool	3256-D-1044 G-28	Meritor ① G&W ④
Countershaft End Play Checking Tool	3256-C-1043 J-41335	Meritor ① Kent-Moore ②
Flange/Yoke Holding Tool	J-3453	Kent-Moore ②
Holding Cover Plate	3305-W-1141	Meritor ①
Input Shaft Bearing Remover	G-38	G&W ⑤
Input Shaft Bearing Driver	G-35	G&W ⑤
Input Shaft Installer	J-39942	Kent-Moore ②
Seal Remover (Light Duty Puller Set)	CG2400B	Snap-On ④
Seal Driver	J-39161	Kent-Moore ②
Seal Driver	3256-Z-1014	Meritor ①
Spacer Washer	1229-N-4538	Meritor ①
T-Handle Tool	3256-Y-1013	Meritor ①

NOTES:

- ① Meritor tools are available wherever Meritor parts are sold.
- ② Order Kent-Moore Tools from Kent-Moore Heavy Duty Division, 29874 Little Mack, Roseville, MI 48066-2298.
- ③ Order Owatonna Tools from OTC Tool and Equipment Division, 655 Eisenhower Drive, Owatonna, MN 55060.
- ④ Contact your local Snap-On tool distributor.
- ⑤ Order G&W Tools from G&W Tool Company, 1105 E. Louisville, Broken Arrow, OK 74012

Index

- Air Filter and Regulator Assembly
 - Installing, 29
 - Removing, 28
- Air Line
 - Identification (9-,10-Speed), 226
 - Identification (13-Speed), 228
 - Location (9-,10-Speed), 225
 - Location (13-Speed), 227
- Auxiliary Case
 - Assembling (9-, 10-Speed), 163
 - Assembling (13-Speed), 181
 - Disassembling (9-,10-Speed), 155
 - Disassembling (13-Speed), 173
 - Installing (9-,10-Speed), 90
 - Installing (13-Speed), 98
 - Removing (9-,10-Speed), 85
 - Removing (13-Speed), 94
- Auxiliary Countershaft
 - Assembling (9-,10-Speed), 166
 - Assembling (13-Speed), 185
 - Disassembling (9-,10-Speed), 160
 - Disassembling (13-Speed), 179
 - End Play, 199-205
 - Installing (9-,10-Speed), 166
 - Installing (13-Speed), 186
 - Removing (9-,10-Speed), 159
 - Removing (13-Speed), 177
 - Timing (9-,10-Speed), 163
 - Timing (13-Speed), 183
- Auxiliary Drive Gear
 - Assembling, 136
 - Disassembling, 134
 - Installing, 103
 - Removing, 102
- Auxiliary Low Gear
 - Timing Mark, 163
- Bearing Cone and Cup
 - Inspecting, 15-18
 - Replacement Chart, 15
- Bearing Cone, Auxiliary Countershaft,
 - Installing (9-,10-Speed), 166
 - Installing (13-Speed), 185
 - Removing (9-,10-Speed), 160
 - Removing (13-Speed), 179
- Bearing Cone, Main Countershaft,
 - Front, Lower
 - Installing,
 - Removing,
 - Front, Upper
 - Installing, 126-129
 - Removing, 106-107
 - Rear, Lower
 - Installing,
 - Removing,
 - Rear, Upper
 - Installing, 154
 - Removing, 151
- Bearing Cup, Auxiliary Countershaft,
 - Front
 - Installing (9-,10-Speed),90, 172
 - Installing (13-Speed), 191
 - Removing (9-,10-Speed), 89
 - Removing (13-Speed), 97
 - Rear
 - Installing (9-,10-Speed), 168-169
 - Installing (13-Speed), 187
 - Removing (9-,10-Speed), 158
 - Removing (13-Speed), 176
- Bearing Cup, Main Countershaft, Front,
 - Lower
 - Installing,
 - Removing, 106-107
- Bearing Cup, Main Countershaft, Front,
 - Upper
 - Installing, 126-130
 - Removing, 108
- Bearing Cup, Main Countershaft, Rear,
 - Lower
 - Installing,
 - Removing,
 - Upper
 - Installing,
 - Removing,
- Breather Vent, 22

Index

- Cleaning
 - Ground Parts, 19
 - Polished Parts, 19
 - Rough Parts, 19
- Clutch Housing
 - Installing, 83
 - Removing, 83
- Corrosion, 19
- Description, 5
- Dowel Pin
 - Installing, 91, 99
 - Removing, 87, 97
- Drying Parts, 19
- End Play
 - Auxiliary Countershaft, 199
 - Main Countershaft, 192
- Identification, 6
- General Information, 5
- Gasket
 - Installing, 12
 - Patterns, 13-14
 - Removing, 12
 - Specifications, 12
- General Information, 5
- HI-LO Fork
 - Installing (9-,10-Speed), 170-171
 - Installing (13-Speed), 187-188
 - Removing (9-,10-Speed), 158-159
 - Removing (13-Speed), 175
- Holding Cover Template, 229
- Input Shaft
 - Installing, 81, 119
 - Removing, 79, 110
- Inspecting Parts, 15
- In-Vehicle Service, 25
- Leaks, 22, 209
- Lubrication, 20
- Main Case, 104-133
- Main Countershaft
 - Assembling, 152
 - Disassembling, 150
 - End Play, 192
 - Installing, 123
 - Removing, 113
- Mainshaft
 - Assembling, 139
 - Disassembling, 137
 - Installing, 125
 - Removing, 104
- Maintenance, 20
 - Scheduled, 21
- Magnets
 - Installing, 117
 - Removing, 116
- Noises, 210
- OD (Overdrive) Gear
 - Timing Marks, 181
- Oil Capacities, 214
- Oil Coolers, 20
- Oil Draining, 23
- Oil Level
 - Adjusting, 21
 - Checking, 21
- Oil Pump
 - Installing, 118
 - Removing, 115
- Oil Replacing, 23
- Oil Seal
 - Installing, 30
 - Removing, 29
- Oil Specifications, 20, 214
- Operating Conditions, 211
- Output Shaft
 - Assembling (9-,10-Speed), 164
 - Assembling (13-Speed), 181
 - Disassembling (9-,10-Speed), 161
 - Disassembling (13-Speed), 177
 - Installing (9-,10-Speed), 166
 - Installing (13-Speed), 183
 - Removing (9-,10-Speed), 160
 - Removing (13-Speed), 176
- Output Yoke
 - Installing, 30
 - Removing, 29
- Piston
 - Installing (9-,10-Speed), 172
 - Installing (13-Speed), 190
 - Removing (9-,10-Speed), 156
 - Removing (13-Speed), 174

Index

- Piston Housing
 - Installing, 190-191
 - Removing, 174
- PTO Covers
 - Installing, 117
 - Removing, 116
- Range Cylinder
 - Installing, 171-172
 - Removing, 156
- Repairing Parts, 19
- Replacing Parts, 19
- Remote Control Assembly
 - Adjusting, 24
 - Installing, 33
 - Lubricating, 24
 - Removing, 33
- Remote Shift Housing
 - Adjusting, 24
 - Installing, 33
 - Lubricating, 24
 - Removing, 33
- Reverse Idler Gear
 - Installing, 118
 - Removing, 104
- Rust, 19
- Scheduled Maintenance, 21
- Seal
 - Installing, 30
 - Removing, 29
- Sealant
 - Installing, 12
 - Patterns, 13-14
 - Removing, 12
 - Specifications, 12
- Shift Lever and Tower Assembly
 - Assembly (Aluminum), 43
 - Assembly (Cast Iron), 47
 - Disassembly (Aluminum), 41
 - Disassembly (Cast Iron), 46
 - Installing, 25
 - Removing, 25
- Shim KIT 5376 Chart, 197
- Shuttle Valve
 - Installing, 191
 - Removing, 174
- Slave Valve
 - Installing, 27
 - Removing, 27
- Snap Ring Chart, 194
- Special Tools, 230
- Splitter Fork
 - Assembling, 183-184
 - Disassembling, 178
 - Installing, 186-187
 - Removing, 177
- Synchronizer
 - Assembling, 167, 184
 - Disassembling, 159, 177
 - Installing, 168, 187
 - Removing, 159, 176
- Timing, 9
- Top Cover
 - Assembling (Standard), 60
 - Assembling ("X" Bar), 72
 - Disassembling (Standard), 54
 - Disassembling ("X" Bar), 66
 - Identification, 50
 - Installing, 52
 - Removing, 50
- Torque, 22, 215-224
- Transmission
 - Installing, 36
 - Removing, 34
- Yoke
 - Installing, 30
 - Removing, 29



ZF Meritor, LLC
22021 Skyway Church Road
Maxton, NC 28364 USA
800-535-5560
www.arvinmeritorinc.com

Information contained in this publication was in effect at the time the publication was approved for printing and is subject to change without notice or liability. ZF Meritor, LLC, reserves the right to revise the information presented or discontinue the production of parts described at any time.

Copyright 2000
ZF Meritor, LLC
All Rights Reserved

Printed in the USA

Maintenance Manual 26A
Revised 12-98
16579/24240