

\$25.00

MERITOR[®]
an *ArvinMeritor* brand

Maintenance Manual MM-96147

Drivelines

Revised 02-04

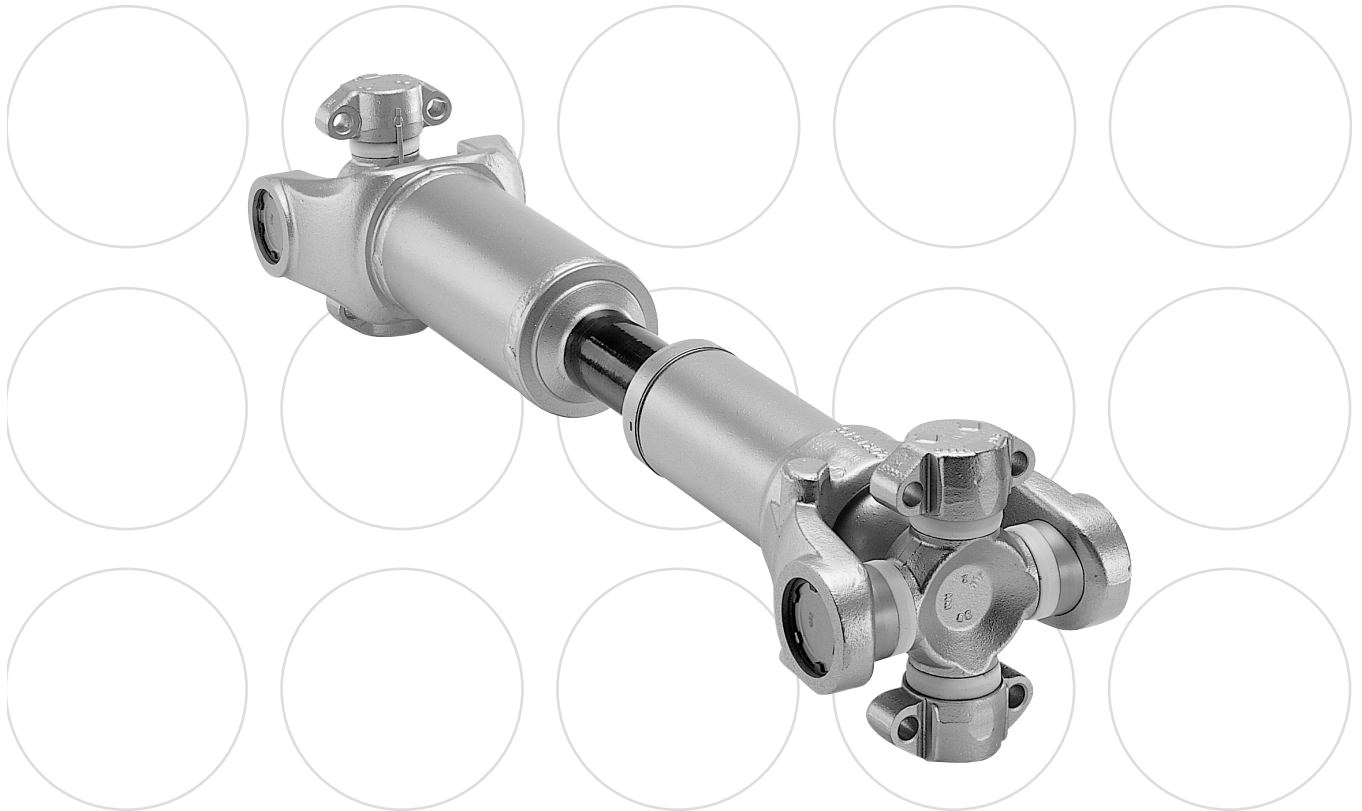

Service Notes

About This Manual

This manual provides maintenance and service procedures for Meritor RPL Series Permalube™, Wing-Style Permalube™, Full-Round, Easy Service™, Wing-Style and 155R Series drivelines.

Before You Begin

1. Read and understand all instructions and procedures before you begin to service components.
2. Read and observe all Warning and Caution hazard alert messages in this publication. They provide information that can help prevent serious personal injury, damage to components, or both.
3. Follow your company's maintenance and service, installation, and diagnostics guidelines.
4. Use special tools when required to help avoid serious personal injury and damage to components.

Hazard Alert Messages and Torque Symbols

WARNING

A Warning alerts you to an instruction or procedure that you must follow exactly to avoid serious personal injury and damage to components.

CAUTION

A Caution alerts you to an instruction or procedure that you must follow exactly to avoid damage to components.

 This symbol alerts you to tighten fasteners to a specified torque value.

How to Obtain Additional Maintenance and Service Information

On the Web

Visit the DriveTrain Plus™ by ArvinMeritor Tech Library at arvinmeritor.com to easily access product and service information. The Library also offers an interactive and printable Literature Order Form.

ArvinMeritor's Customer Service Center

Call ArvinMeritor's Customer Service Center at 800-535-5560.

Technical Electronic Library on CD

The DriveTrain Plus™ by ArvinMeritor Technical Electronic Library on CD contains product and service information for most Meritor, ZF Meritor LLC and Meritor WABCO products. \$20. Specify TP-9853.

How to Obtain Tools and Supplies Specified in This Manual

Call ArvinMeritor's Commercial Vehicle Aftermarket at 888-725-9355 to obtain Meritor tools and supplies.

SPX Kent-Moore, 28635 Mound Road, Warren, Michigan, 48092. Call the company's customer service center at 800-345-2233, or visit their website at spxkentmoore.com.

Tiger Tool. Call the company's customer service center at 800-661-4661, or visit their website at tigertool.com.

Information contained in this publication was in effect at the time the publication was approved for printing and is subject to change without notice or liability. Meritor Heavy Vehicle Systems, LLC, reserves the right to revise the information presented or to discontinue the production of parts described at any time.

Contents

pg. 1	Section 1: Drivelines Components	pg. 24	Section 6: Wing-Style Permalube™ Hazard Alert Messages Removal Driveline Universal Joint Installation Universal Joint
2	Section 2: Introduction Description RPL Series Permalube™ (Non-Greaseable) Wing-Style Permalube™ Full-Round, Easy Service™, Wing-Style and 155R Series (Greaseable)	25	Driveline Lubrication Universal Joint Slip Yoke Splines
4	Section 3: Inspection Hazard Alert Messages Components Driveline End Yokes	26	Section 7: Easy Service™ Hazard Alert Messages Removal Driveline Universal Joint Installation Universal Joint Driveline
5	Universal Joints	27	Lubrication Universal Joint
6	Center Bearings	28	Slip Yoke Splines
7	Slip Yoke	29	Section 8: 155R Series Slip Drive Shaft Assembly Description 155R Series Drive Shaft Configurations
8	Permalube™ Drivelines Inspection and Maintenance	34	Hazard Alert Messages Removal Driveline Universal Joint
9	Universal Joint Capscrews	36	Disassembly Standard Slip Configuration Outboard Slip Configuration
10	Section 4: RPL Series Permalube™ Hazard Alert Messages Removal Driveline	37	Three-Piece Standard/Outboard Slip Driveline Assembly Standard Slip Configuration
11	Universal Joint	38	Installation Universal Joint
13	Disassembly Slip Yoke	40	Driveline
14	Assembly Slip Yoke	41	Lubrication Universal Joint Slip Yoke Splines
16	Installation Wing Bushings Universal Joint		
20	Driveline		
21	Section 5: Full-Round Hazard Alert Messages Removal Driveline Universal Joint Installation Universal Joint		
22	Driveline		
23	Lubrication Universal Joint Slip Yoke Splines		

Contents

pg. 42	Section 9: Center Bearing Removal and Installation	pg. 64	Section 14: Special Tools
	Hazard Alert Messages	65	Section 15: Glossary
	Overview		Definitions
	The Procedures in This Section Apply to All Meritor Drivelines	66	Section 16: Appendix
	Self-Aligning Center Bearings		Important Information
43	Removal		Data Gathering Sheets
	Coupling Shaft		
44	Disassembly		
	Coupling Yoke and Coupling Shaft		
45	Center Bearing		
46	Installation		
	Deflectors		
	Center Bearing		
	Coupling Shaft		
47	Section 10: Lubrication		
	Hazard Alert Messages		
	Maintenance		
	Greaseable Drivelines		
	Non-Greaseable Drivelines		
	Inspection		
	Driveline		
49	Section 11: Fastener and Torque Information		
	Torque Specifications		
	Driveline		
50	Section 12: Troubleshooting		
	Hazard Alert Messages		
	Special Tools		
	Troubleshooting		
54	Section 13: Measuring and Recording Driveline Angles		
	Special Tools		
	Tools You'll Need		
	Overview		
	Prepare the Vehicle		
55	Data Gathering Worksheet		
	General Information Section		
56	Phasing Type Box		
57	Positive (+) and Negative (–) Angle Designations		
	Measure		
	Main Driveline Angles		
60	Adjustment		
	Hints for Driveline Set Up		
61	Driveline Angle Analysis Program		

1 Drivelines

Components

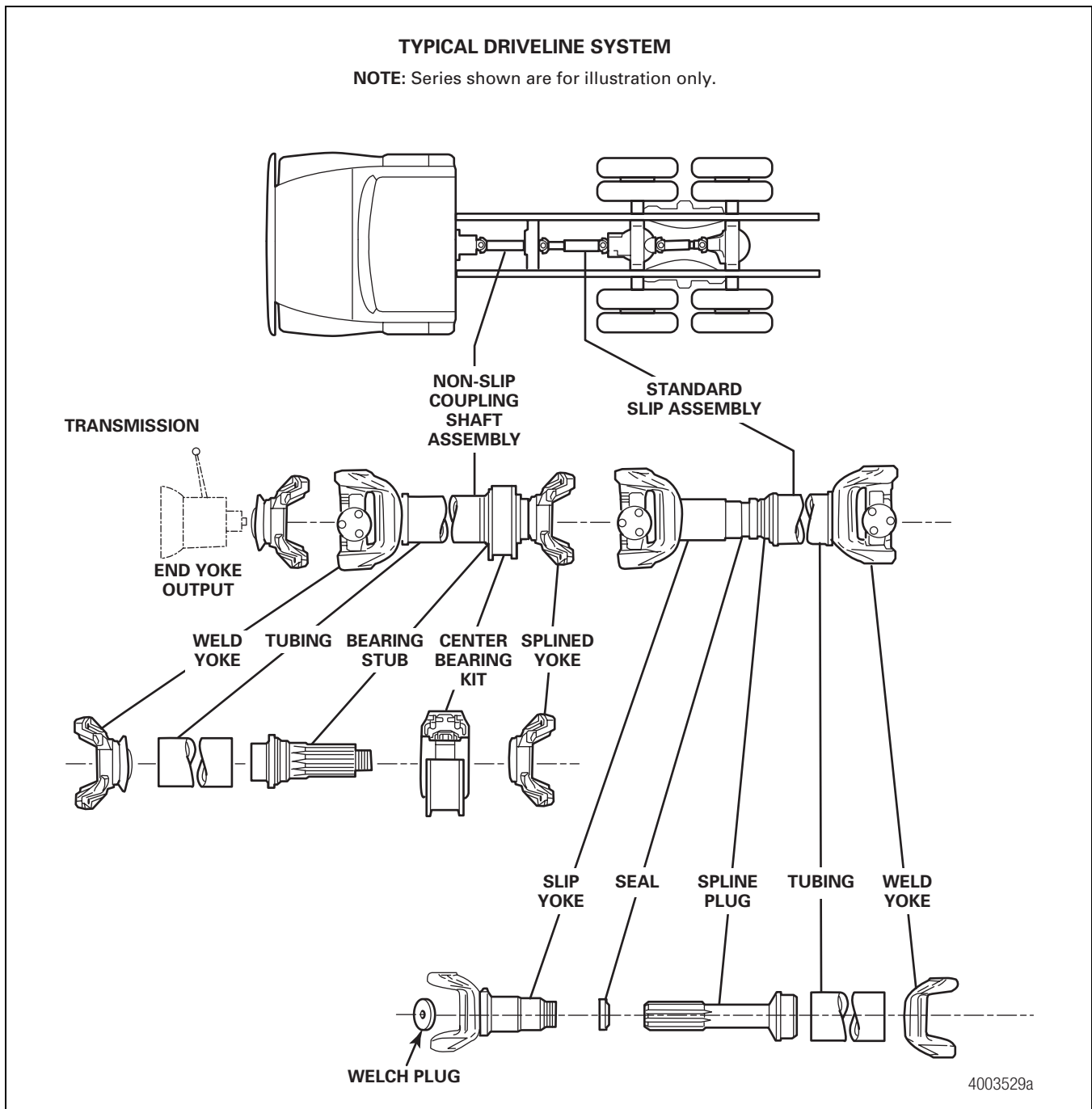

1 Drivelines

TYPICAL DRIVELINE SYSTEM

NOTE: Series shown are for illustration only.

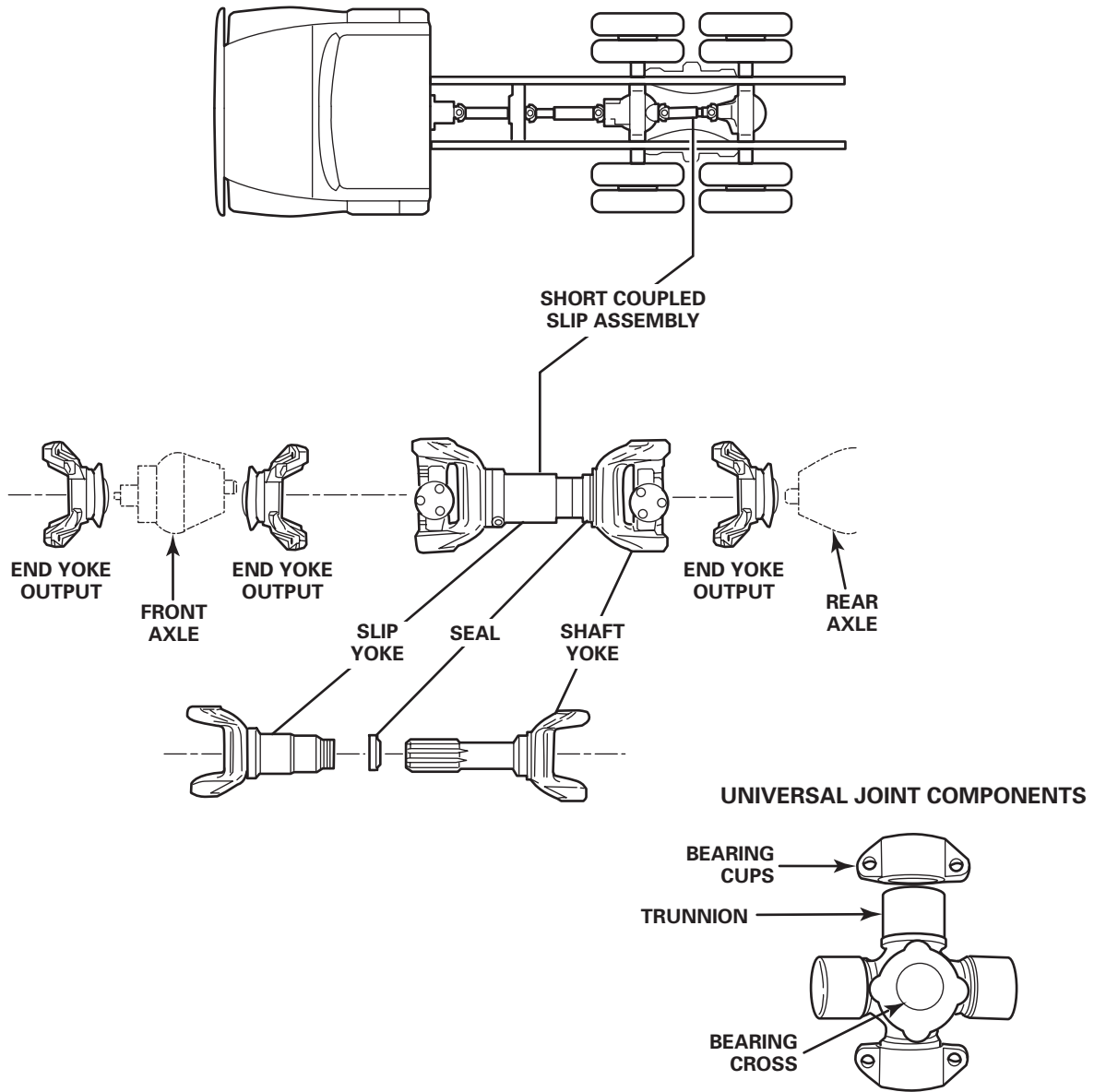

4003528a

2 Introduction

Description

RPL Series Permalube™ (Non-Greaseable)

The Meritor RPL Series Permalube™ non-greaseable driveline is permanently lubricated and sealed at the factory and does not require lubricants. Arrows on the wing bushings help you to correctly install the universal joint. Figure 2.1.

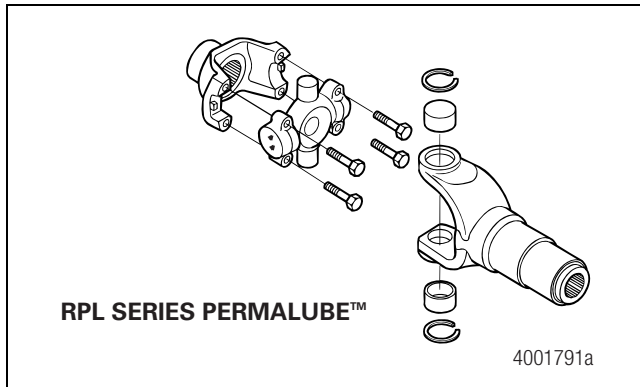

Figure 2.1

Wing-Style Permalube™

The Meritor Wing-Style Permalube™ driveline requires lubrication of the slip yoke splines only. Figure 2.2.

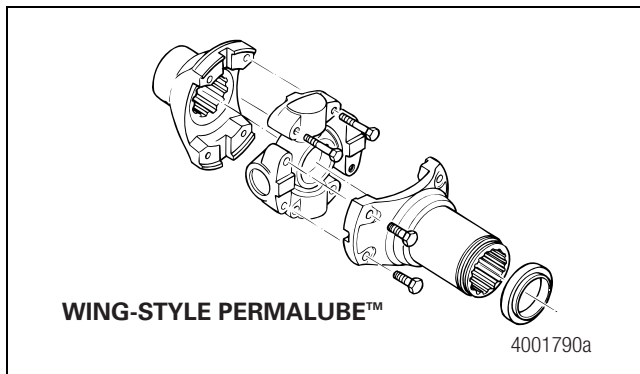

Figure 2.2

Full-Round, Easy Service™, Wing-Style and 155R Series (Greaseable)

Full-Round, Easy Service™, Wing-Style and 155R greaseable drivelines require periodic lubrication of the universal joints and slip yoke splines. Figure 2.3, Figure 2.4, Figure 2.5 and Figure 2.6.

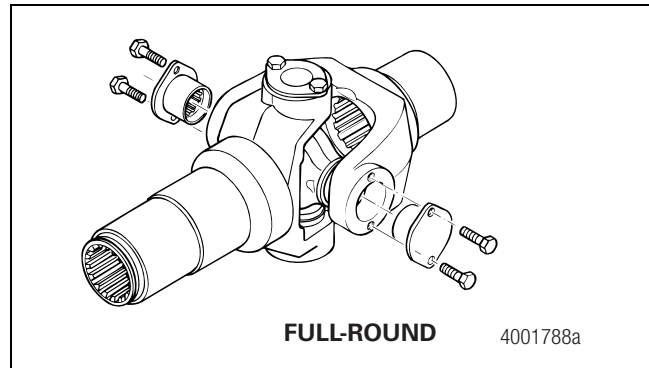

Figure 2.3

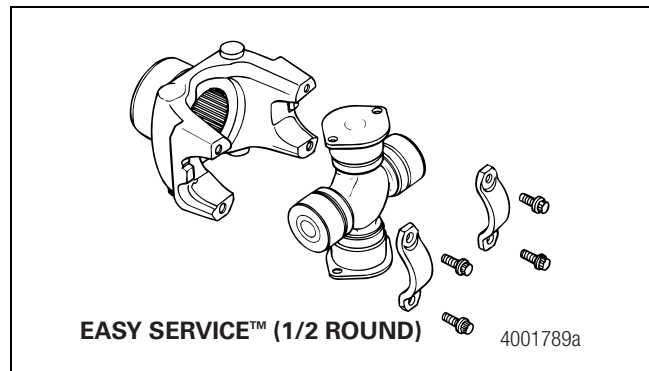

Figure 2.4

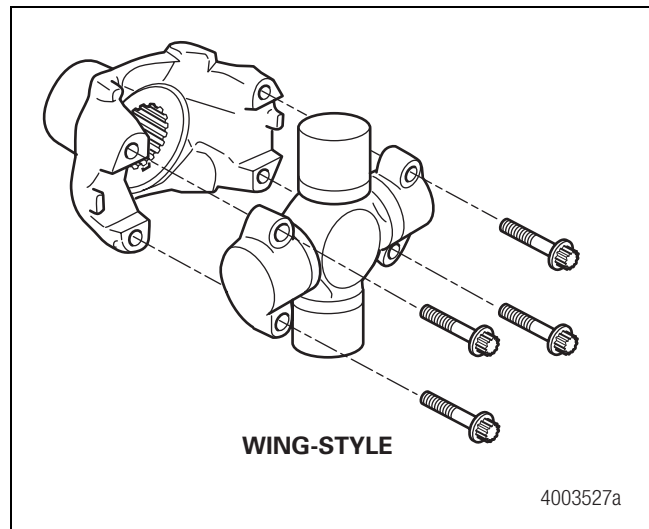

Figure 2.5

2 Introduction

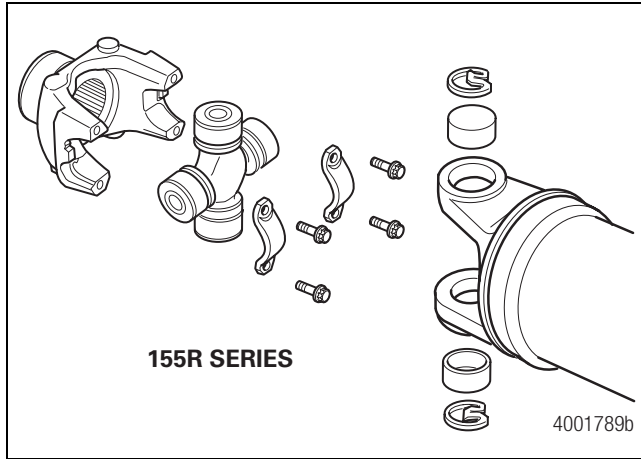

Figure 2.6

3 Inspection

Hazard Alert Messages

Read and observe all Warning and Caution hazard alert messages in this publication. They provide information that can help prevent serious personal injury, damage to components, or both.

⚠ WARNING

Check end yoke retaining nuts and bolts for looseness. Tighten loose fasteners to specification. Check the input and output shaft splines for wear and damage. Replace worn or damaged splines. Check for loose, missing or damaged driveline fasteners and parts. Tighten loose fasteners, and replace damaged and missing parts. Loose, damaged or missing parts can cause the driveline to separate from the vehicle. Serious personal injury and damage to components can result.

To prevent serious eye injury, always wear safe eye protection when you perform vehicle maintenance or service.

Only service a driveline when the engine is OFF. A rotating driveline can cause serious personal injury.

Park the vehicle on a level surface. Block the wheels to prevent the vehicle from moving. Support the vehicle with safety stands. Do not work under a vehicle supported only by jacks. Jacks can slip and fall over. Serious personal injury and damage to components can result.

Components

Driveline

1. Park the vehicle on a level surface. Block the wheels to keep the vehicle from moving. Raise the vehicle so that the area you will service is off the ground.
2. Inspect the driveline at regular intervals. Loose end yokes, excessive radial movement, slip spline radial movement, bent driveline tubing or missing plugs in the slip yoke can damage universal joints and bearings.
3. Check the output and input end yokes on both the transmission and axle for axial looseness. Refer to the axle or transmission manufacturer's service instructions.
 - **If the output and input end yokes are loose:** Disconnect the driveline. Tighten the end yoke retaining nut to the correct specification. Refer to the axle or transmission manufacturer's service instructions.

4. Inspect for worn universal joints. Apply vertical force of about 50 pounds (22.7 kg) to the driveline near the universal joints.
 - **If movement is greater than 0.006-inch (0.152 mm):** Replace the universal joint.
5. Use a dial indicator to examine the slip yoke spline for excessive radial movement. Radial movement between the slip yoke and the tube shaft must not exceed 0.017-inches (0.432 mm).
 - **If the radial movement exceeds 0.017-inch (0.432 mm):** Replace the slip yoke and the tube shaft.
6. Inspect the driveline for damaged or bent tubing. Carefully remove contaminants, such as mud and road debris.

End Yokes

Perform the following procedures before you lubricate universal joints or slip yokes. If you lubricate these components before you inspect them, lubricant can cover wear, damage and looseness.

1. Do not lubricate components. Inspect all input and output end yoke retaining nuts and bolts for gaps between mating surfaces.
 - **If gaps are present:** Refer to the transmission, axle or transfer case manufacturer's service instructions.
2. Use the following procedure to check all input and output end yokes for looseness.
 - A. Hold the end yoke with both hands.
 - B. Move the end yoke UP-AND-DOWN and SIDE-TO-SIDE. There shouldn't be any movement where the yoke connects to the input and output shafts. Figure 3.1.

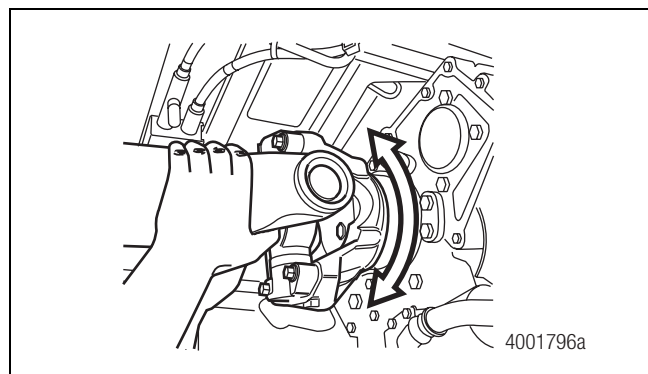

Figure 3.1

3 Inspection

- **If the input and output end yokes are loose:** Disconnect the driveline. Tighten the end yoke retaining nut or bolt to the correct specification. Refer to the axle or transmission manufacturer for correct inspection and replacement procedures.
 - **If the input and output end yokes are not loose, check that the transmission output shaft and axle input shaft splines aren't loose at the end yoke:** Hold the yoke with one hand and rotate it LEFT-TO-RIGHT while you check end play for radial looseness. Figure 3.1.
 - **If you find excessive radial looseness:** Replace the end yoke, or input or output shafts, as necessary.
3. Inspect for worn, damaged, missing and loose parts. Replace as required. Refer to the appropriate sections in this manual for these procedures.

⚠ WARNING

Use a fine-tooth file or an emery cloth to remove raised metal or fretting from yoke cross hole surfaces. Take care not to remove an excessive amount of metal. These conditions can damage the cross and bearing and cause the driveline to separate from the vehicle. Serious personal injury and damage to components can result.

4. Inspect all end yoke cross hole surfaces and bolt hole threads for damage. Remove raised metal or fretting with a fine-tooth file or emery cloth. Figure 3.2.
- **If bolt hole threads are damaged:** Replace the yoke.

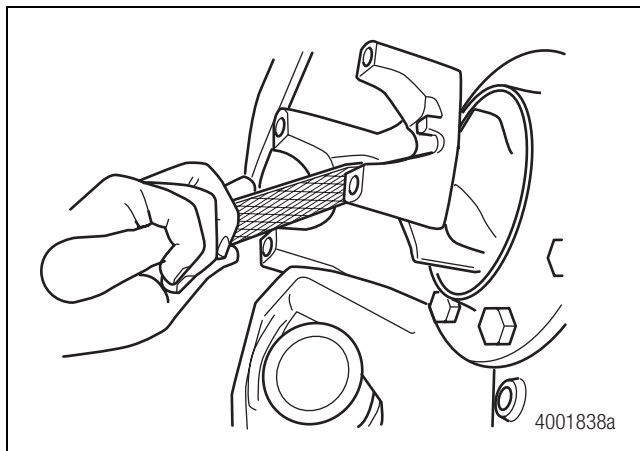

Figure 3.2

Universal Joints

⚠ WARNING

Excessive looseness across the ends of the universal joint bearing cup assemblies can cause imbalance or vibration in the driveline assembly. Imbalance or vibration can cause component wear, which can result in separation of the driveline from the vehicle. Serious personal injury and damage to components can result.

1. Use the following procedure to check for looseness across the ends of the universal joint bearing cup assemblies and trunnions.
 - A. Hold the INBOARD yoke on the driveline with both hands.
 - B. Try to move the yoke UP-AND-DOWN and SIDE-TO-SIDE by applying at least 50 lb-ft (222.5 N•m) of force to the driveline near the universal joints. Figure 3.3.

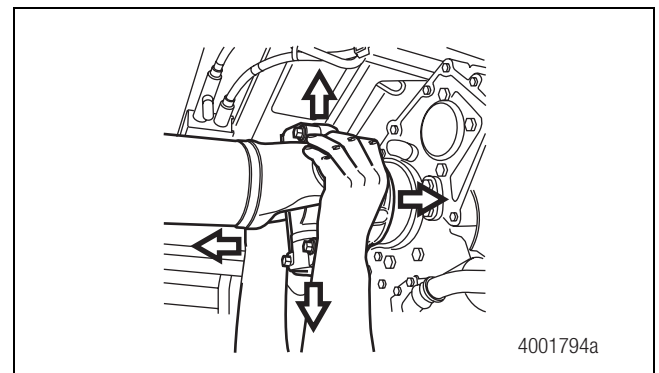

Figure 3.3

- **If movement is greater than 0.006-inch (0.152 mm):** Replace the universal joint.
2. Inspect all universal joint kits in the driveline assembly.

Greaseable Universal Joints

1. Check that all grease fittings are installed. Replace missing or damaged fittings. Tighten them to 6 lb-ft (8 N•m). Figure 3.4. **ⓘ**
2. Check for loose grease fittings. Tighten them to 6 lb-ft (8 N•m). **ⓘ**

3 Inspection

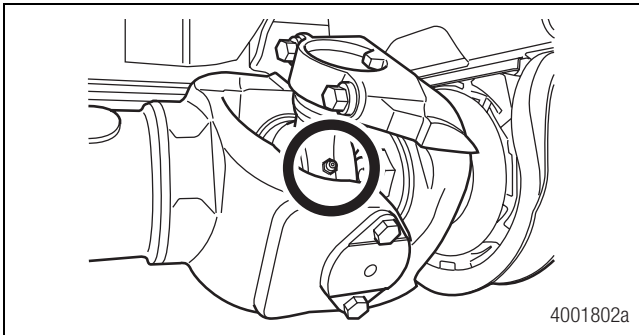



Figure 3.4

Center Bearings

1. Inspect all center bearing and end yoke midship nuts for gaps between the mating surfaces. Figure 3.5.

- **If you can see gaps between the mating surfaces:** Disconnect the driveline. Tighten the coupling yoke retaining nut to 450-600 lb-ft (612-816 N•m). 

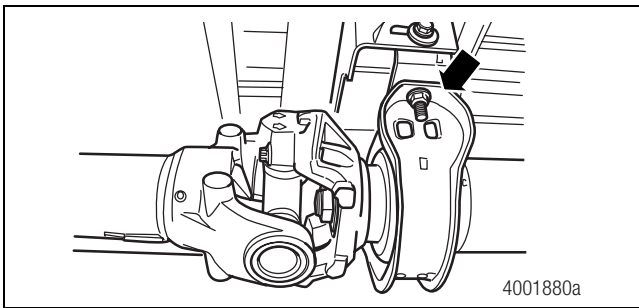

Figure 3.5

2. Inspect the center bearing bracket bolts for looseness. Figure 3.6.

- **If the bolts are loose:** Verify that the bracket is aligned correctly before you tighten the bolts. Tighten the center bearing bracket bolts. Refer to the vehicle manufacturer's procedures for the correct torque specification.

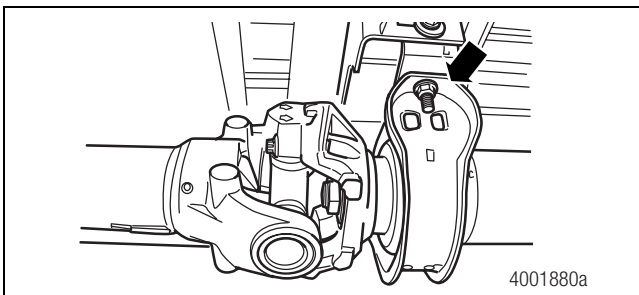

Figure 3.6

3. Inspect the center bearing rubber cushion for damage. If equipped, check that the deflectors are not rubbing against the rubber cushion. Verify that the rubber cushion is correctly seated in the metal bracket.

- **If any of these conditions are evident:** Replace the center bearing assembly.

Self-Aligning Center Bearings

A self-aligning center bearing accepts \pm five degrees of angular misalignment. This helps to ensure that the hanger bearing is correctly aligned to the driveline under all operating conditions.

Use the same service procedures for a self-aligning center bearing as for a standard center bearing. You can identify a self-aligning center bearing by the bright gold color of the integral deflector.

Deflectors are integral to a self-aligning center bearing, so separate deflectors are not required.

Some vehicles manufactured after January 18, 2002, are equipped with self-aligning center bearings. Figure 3.7.

- **If you replace a self-aligning center bearing on a vehicle manufactured after January 18, 2002:** You must install a new self-aligning center bearing. Do not install an original-design bearing.

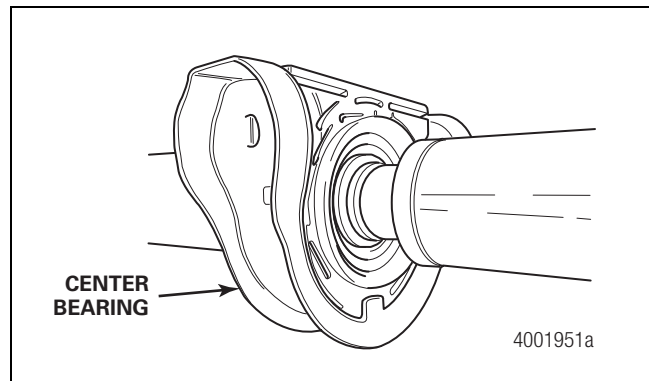

Figure 3.7

3 Inspection

Slip Yoke

NOTE: Check a slip yoke for movement with the driveline installed and the vehicle on a level surface with its wheels on the ground.

1. Check that the vehicle is on a level surface with its wheels on the ground. The driveline should be installed.
2. Firmly mount a dial indicator with a magnetic base onto the slip yoke barrel next to the dust seal. Figure 3.8. You don't want the dial indicator to move when you check the slip yoke for looseness, or the measurement will not be correct.

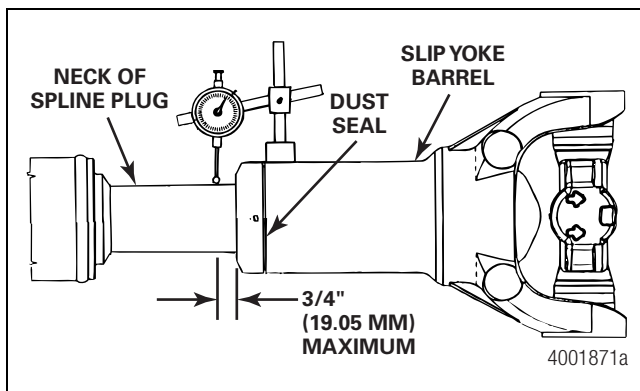

Figure 3.8

3. Extend the dial indicator arm from the base, so that it contacts the neck of the spline plug within 3/4-inch (19.05 mm) from the dust seal. Figure 3.8.
4. With your hands near the center of the driveline, move the slip yoke UP-AND-DOWN. Check the dial indicator measurement. Movement between the spline plug and slip yoke must not exceed 0.017-inch (0.432 mm). Figure 3.9.
 - **If movement exceeds 0.017-inch (0.432 mm):** Components are worn or damaged. Replace as required.

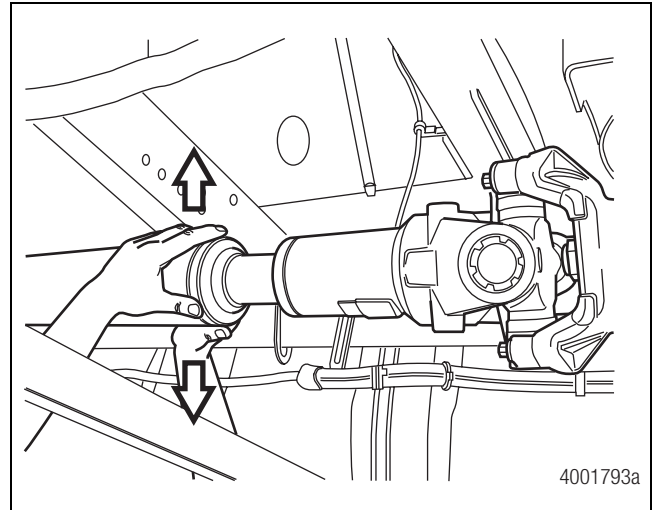

Figure 3.9

5. Inspect the driveline for damage or bent tubing.
 - **If the driveline is damaged or bent:** Replace the driveline.
6. If necessary, carefully remove mud or road debris from the driveline.
7. Inspect the slip yoke spline seal for grease leakage or seal damage.
8. Inspect for missing balance weights, damaged tubing or a missing welch plug at the slip yoke.

3 Inspection

Permalube™ Drivelines

Inspection and Maintenance

Table A: RPL Series Permalube™ and Wing-Style Permalube™ Driveline Inspection Intervals and Procedures

Mileage Intervals	Procedures
At initial inspection, or no more than 2,000 miles (3200 km)	<ul style="list-style-type: none">• Verify that all bolts are tightened to 115-135 lb-ft (155-183 N•m). 
Every 25,000 miles (40 000 km)	<p>If you observe any of the following conditions, remove and replace components as needed.</p> <ol style="list-style-type: none">1. Check for excessive looseness across the ends of the universal joint bearing cup assemblies and trunnions.<ul style="list-style-type: none">• Grip the driveline near the inboard yoke with both hands.• Try to move the yoke vertically and horizontally. Movement in the universal joint relative to the inboard or outboard yokes must not exceed 0.006-inch (0.152 mm). Figure 3.10.2. Inspect the slip yoke spline seal for grease leakage or seal damage.3. Inspect for missing balance weights, damaged tubing or a missing welch plug at the slip yoke.
Every 150,000 miles (240 000 km)	<p>In addition to the 25,000-mile (40 000 km) requirements:</p> <ul style="list-style-type: none">• Use a dial indicator to inspect the slip splines for wear (backlash). Radial looseness between the slip yoke and the tube shaft must not exceed 0.017-inch (0.432 mm). Figure 3.11.

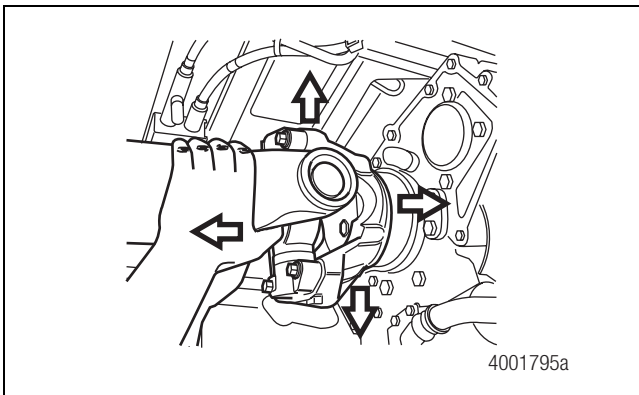

Figure 3.10

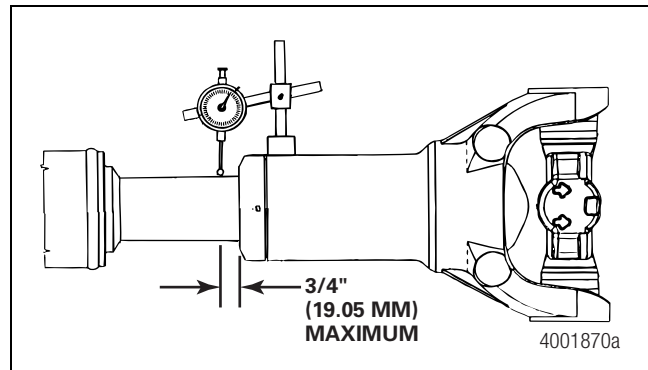

Figure 3.11

3 Inspection

Universal Joint Capscrews

⚠ WARNING

Inspect RPL Series Permalube™ and Wing-Style Permalube™ drivelines for loose or missing capscrews and lock washers. Loose or missing fasteners can allow the driveline to separate from the vehicle. Serious personal injury and damage to components can result. If fasteners are loose or missing:

- **RPL Series Permalube™ drivelines:** Install new capscrews with Dri-Loc patches.
- **Wing-Style Permalube™ drivelines:** Install new capscrews with Dri-Loc patches and secure the capscrews with lock washers.

Meritor recommends that you inspect RPL Series Permalube™ bearing cup capscrews and wing-style capscrews and lock washers at initial inspection, or no more than 2,000 miles (3200 km).

RPL Series Permalube™ Drivelines

1. Check that capscrews are installed on all universal joint positions. RPL Series Permalube™ capscrews and Wing-Style Permalube™ capscrews are not interchangeable.
 - **If capscrews are missing:** Check for damage to the universal joint and yoke. Replace damaged parts and missing capscrews.
 - **If capscrews are loose:** Remove and discard loose capscrews. Replace them with new capscrews.
2. Use a torque wrench to verify that capscrews are tightened to 115-135 lb-ft (155-183 N•m). **ⓘ**

Wing-Style Permalube™ Drivelines

1. Check that both capscrews and lock washers are installed on all universal joint positions. RPL Series Permalube™ capscrews and Wing-Style Permalube™ capscrews are not interchangeable.
 - **If capscrews and lock washers are missing:** Check for damage to the universal joint and yoke. Replace damaged parts, capscrews and lock washers. Refer to Section 6.
 - **If capscrews are loose:** Remove and discard loose capscrews. Replace them with new capscrews and lock washers.
2. Use a torque wrench to verify that capscrews are tightened to the correct specification. Refer to Section 11.

Check End Play

1. Check the universal joint for end play. Apply force in an UP-AND-DOWN and SIDE-TO-SIDE motion. The universal joint must not move in either direction. Figure 3.12. There should be less than 0.006-inch (0.152 mm) BACK-AND-FORTH motion of the universal joint. Figure 3.13.
 - **If movement is greater than 0.006-inch (0.152 mm):** Replace the universal joint.

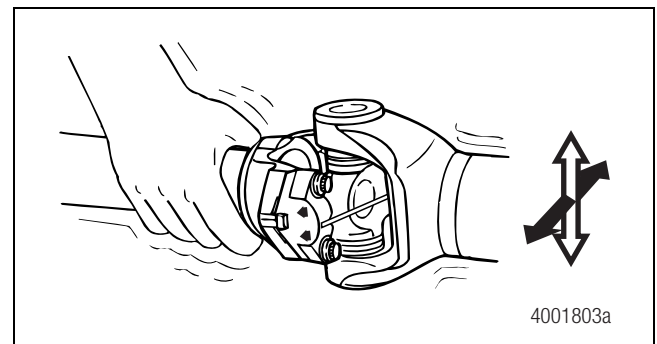

Figure 3.12

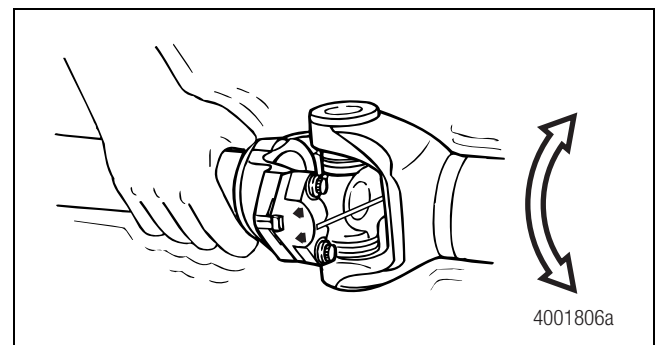

Figure 3.13

⚠ CAUTION

A broken weld strap can cause a wing bushing to rotate. When a bushing rotates, it's possible to assemble it into the yoke backward. To ensure correct assembly and prevent damage to components, you must insert both of the wing bushing's machined keyways into the yoke.

2. Replace the universal joint if it's loose or the weld strap is broken or missing.

Hazard Alert Messages

Read and observe all Warning and Caution hazard alert messages in this publication. They provide information that can help prevent serious personal injury, damage to components, or both.

⚠ WARNING

To prevent serious eye injury, always wear safe eye protection when you perform vehicle maintenance or service.

Use a brass or leather mallet for assembly and disassembly procedures. Do not hit steel parts with a steel hammer. Pieces of a part can break off and cause serious personal injury.

Only install the correct grade new bearing retainer bolts and stamped strap bolts. Do not reuse these parts. If the bearing retainer straps are damaged, install new retainers. Damaged and reused parts can affect driveline operation, which can cause the driveline to separate from the vehicle. Serious personal injury and damage to components can result.

A driveline assembly can weigh more than 100 pounds (46 kilograms). Always use lifting devices and the correct procedures when you handle drivelines to prevent serious personal injury and damage to components.

Removal

Driveline

⚠ WARNING

Only service a driveline when the engine is OFF. A rotating driveline can cause serious personal injury.

Park the vehicle on a level surface. Block the wheels to prevent the vehicle from moving. Support the vehicle with safety stands. Do not work under a vehicle supported only by jacks. Jacks can slip and fall over. Serious personal injury and damage to components can result.

1. Park the vehicle on a level surface. Block the wheels to keep the vehicle from moving. Raise the vehicle so that the area you will service is off the ground. Support the vehicle with safety stands.
2. Use a 12-point socket to loosen the four bolts (1/2 x 20-inch thread) located in the weld yoke end of the driveline. Figure 4.1.

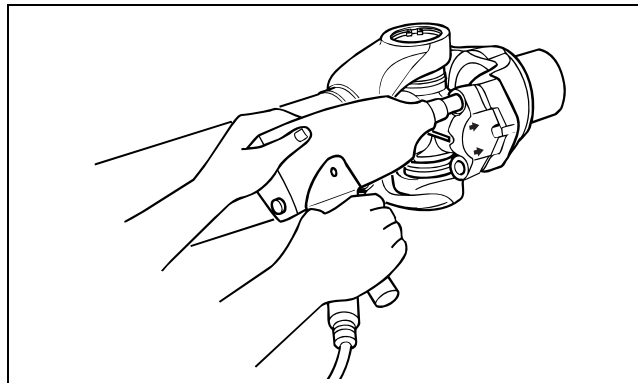

Figure 4.1

3. Remove the bolts. Figure 4.2.

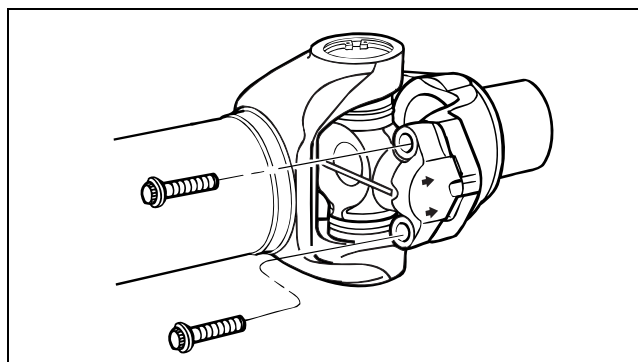

Figure 4.2

NOTE: Support the driveline when you remove it from the end yoke.

4. If necessary, use an appropriate tool to tap the wing bushing from the end yoke. Figure 4.3.
5. Repeat Step 2 through Step 4 to remove the opposite end of the driveline.

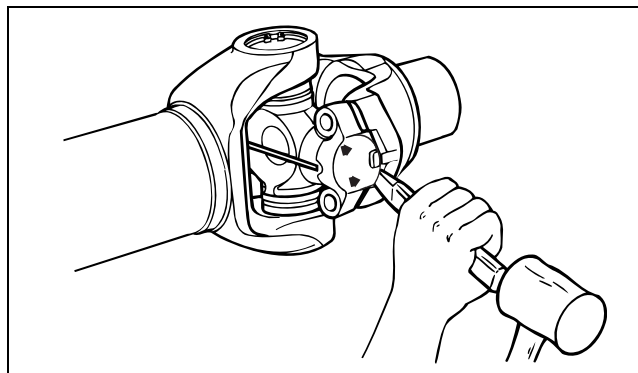

Figure 4.3

4 RPL Series Permalube™

Universal Joint

Snap Ring

NOTE: Refer to the Service Notes page on the front inside cover of this manual for information on how to obtain SPX Kent-Moore tools.

1. Use snap ring pliers (SPX Kent-Moore tool number J-44676-1) to remove the snap rings. Figure 4.4.

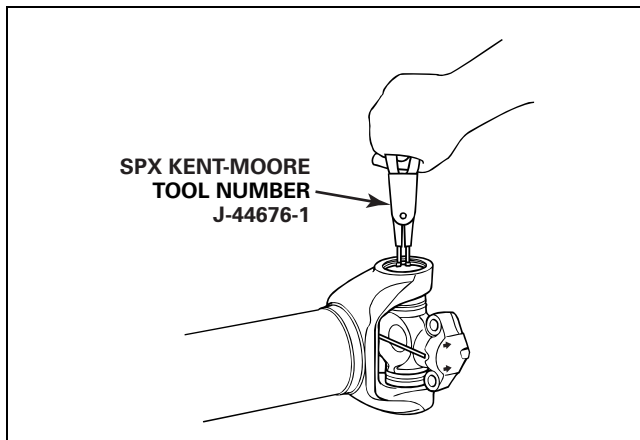

Figure 4.4

2. If necessary, use a brass drift and lightly tap the center of the bushing to assist in snap ring removal. Figure 4.5.

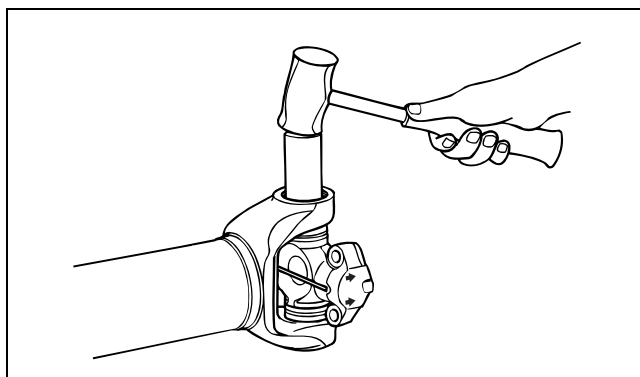

Figure 4.5

3. Repeat the previous steps on the other side of the yoke.

Round Bushings

NOTE: Use only the specified tools to remove the round bushings. Do not use the SPX Kent-Moore yoke bearing cup installation tool (number J-44516) to remove the round bushings. Damage to the tool can result.

Use one of the following procedures to remove and install round bushings.

- Press, bridge and bearing cup receiver
- Universal joint press
- Universal joint puller

⚠ WARNING

Observe all warnings and cautions provided by the press manufacturer to avoid damage to components and serious personal injury.

Using a Press, Bridge and Bearing Cup Receiver

1. Use a press bridge (SPX ICM Kent-Moore tool number J-42368-1) and bearing cup bushing receiver (SPX Kent-Moore tool number J-42368-2). Figure 4.6. Refer to the Service Notes page on the front inside cover of this manual for information to obtain these tools.

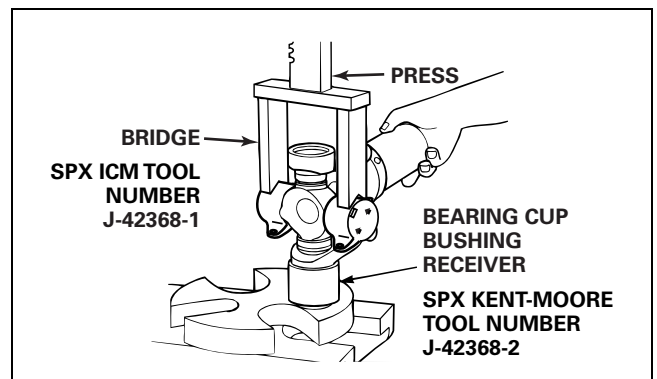

Figure 4.6

2. Press DOWN until the first round bushing loosens. Figure 4.6. Remove the round bushing. Figure 4.7.

4 RPL Series Permalube™

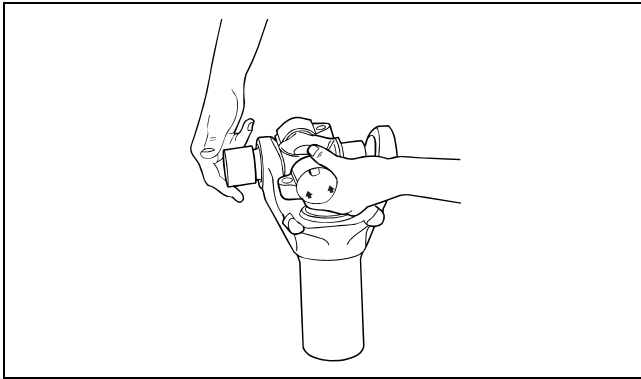

Figure 4.7

3. Rotate the shaft 180 degrees. Repeat the procedure for the opposite side of the universal joint. Figure 4.8.

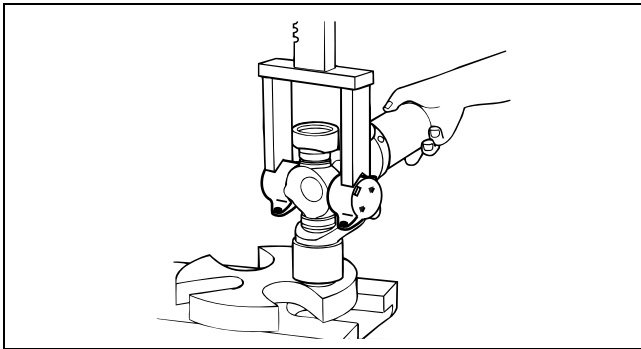

Figure 4.8

4. Remove the universal joint from the yoke.

Using a Universal Joint Press

1. Position a universal joint press (Tiger Tool number 10707). Figure 4.9. Refer to the Service Notes page on the front inside cover of this manual for information to obtain this tool.

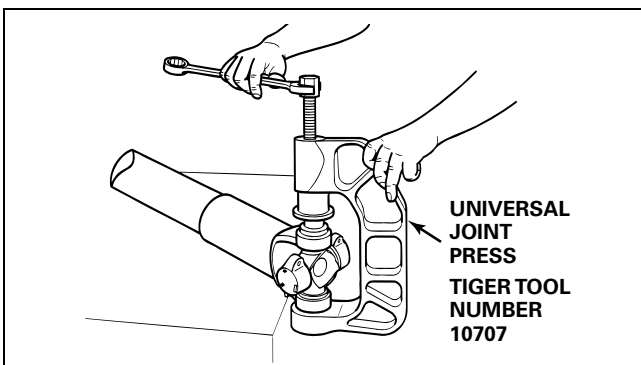

Figure 4.9

2. Turn the screw on the tool CLOCKWISE until the round bushing loosens.
3. Turn the screw on the tool COUNTERCLOCKWISE until you can remove the round bushing.
4. Turn over the universal joint. Repeat the procedure for the opposite side of the universal joint.
5. Remove the universal joint from the yoke.

Using a Universal Joint Puller

1. Position a universal joint puller (Tiger Tool number 10102). Refer to the Service Notes page on the front inside cover of this manual for information to obtain this tool. Figure 4.10.

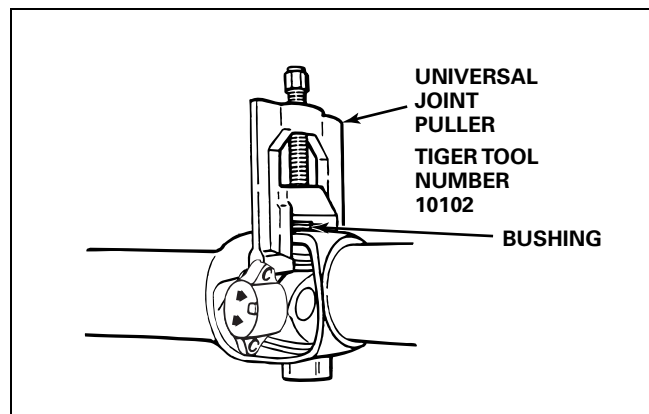

Figure 4.10

2. Turn the screw on the tool CLOCKWISE until the round bushing loosens.
3. Turn the screw on the tool COUNTERCLOCKWISE and remove the round bushing.
4. Turn over the universal joint. Repeat the procedure for the opposite side of the universal joint.
5. Remove the universal joint from the yoke.

4 RPL Series Permalube™

Disassembly

Slip Yoke

1. Use a brass or copper hammer and a drift to tap the shroud off the slip seal. Figure 4.11.

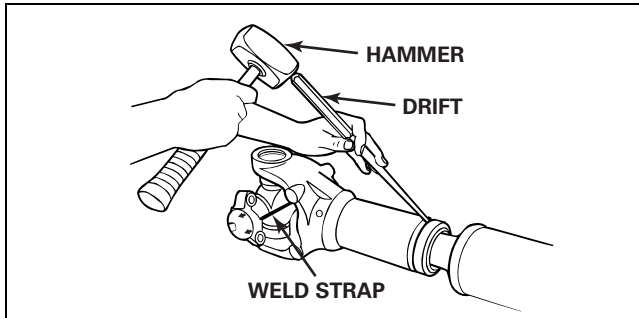

Figure 4.11

2. Use a screwdriver to pry the seal out of the groove in the slip yoke. Figure 4.12.

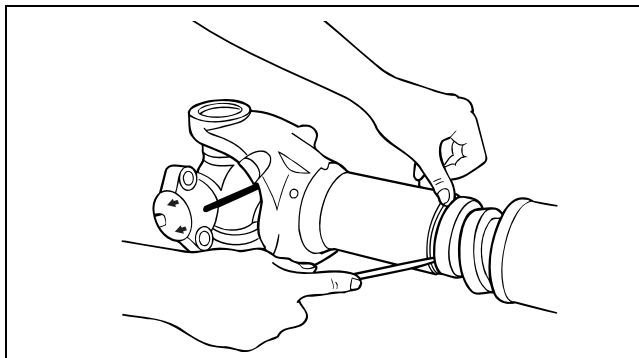

Figure 4.12

3. Mark the slip yoke and slip shaft sections to ensure that you reassemble them into their original positions. Figure 4.13.

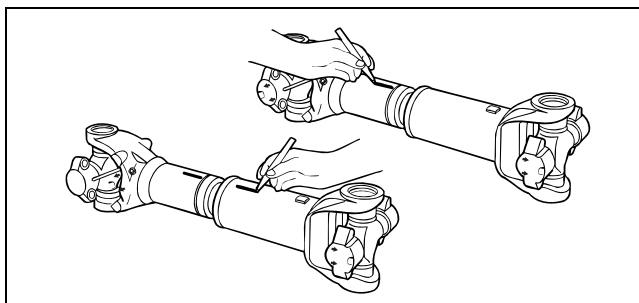

Figure 4.13

4. Pull the slip yoke and slip shaft sections apart. Figure 4.14.

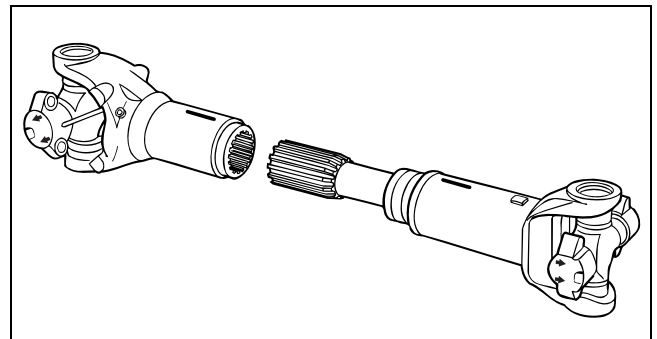

Figure 4.14

5. Remove the seal. Figure 4.15. Remove the shroud. Figure 4.16.

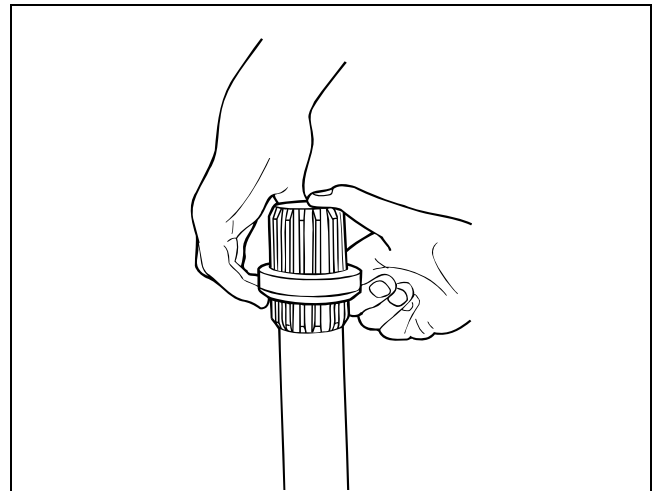

Figure 4.15

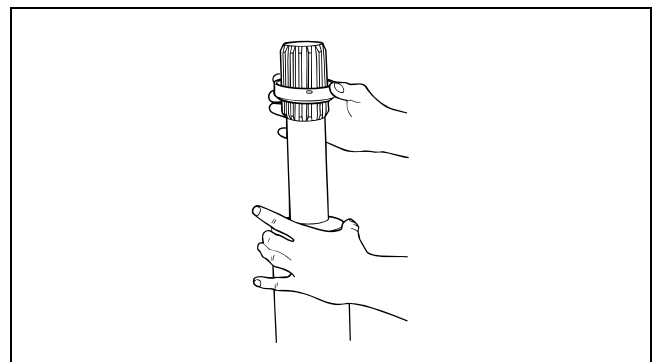

Figure 4.16

4 RPL Series Permalube™

Assembly

Slip Yoke

1. Use an Allen wrench to remove the grease plug from the slip yoke before you assemble the slip yoke and spline shaft sections. Figure 4.17.

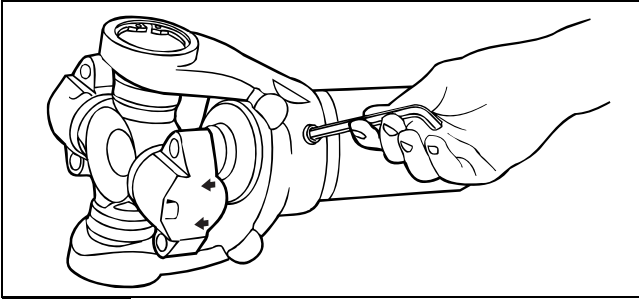

Figure 4.17

2. Use the grease packet supplied with the slip yoke to apply the entire amount of grease into the slip yoke. Figure 4.18.

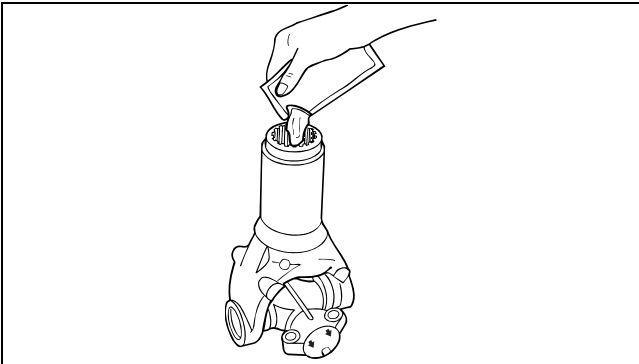

Figure 4.18

3. Use a brush to distribute lubricant on the splines. Figure 4.19.

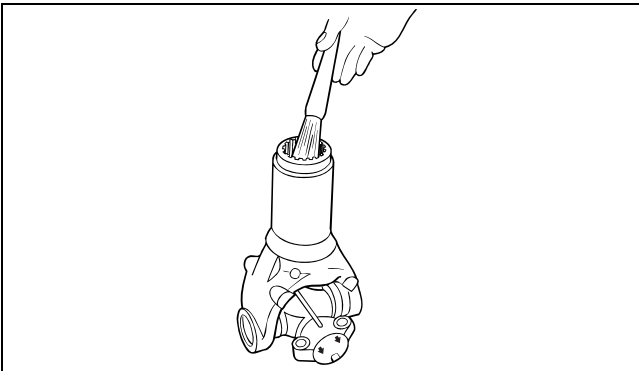

Figure 4.19

4. Install the new shroud. Figure 4.20.

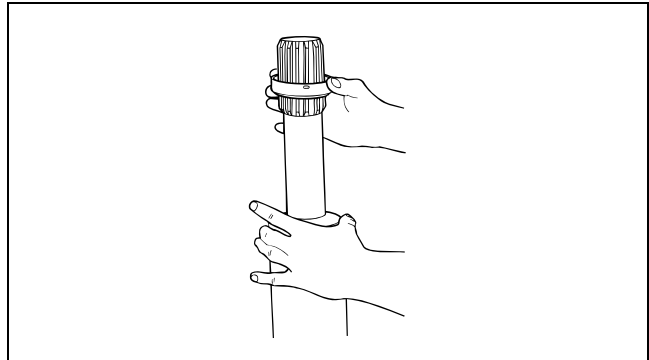

Figure 4.20

5. Install the new seal onto the spline shaft neck. Ensure that the small diameter side fits onto the splines first. Figure 4.21.

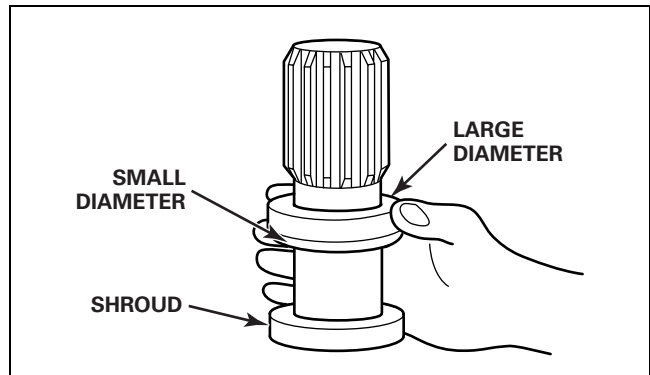

Figure 4.21

6. Align the slip yoke and spline shaft sections with the phasing marks you made on these sections during disassembly. Figure 4.22.

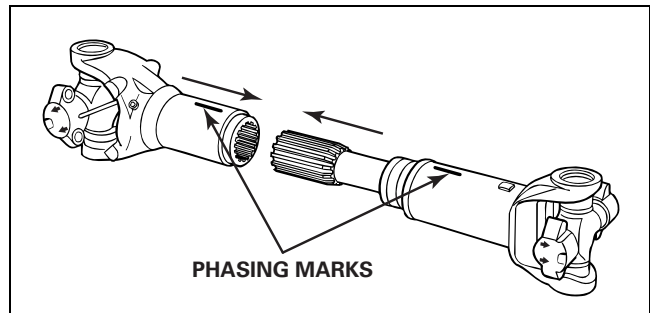

Figure 4.22

4 RPL Series Permalube™

7. Install the spline shaft into the slip yoke until the splines fully engage. Figure 4.22.
8. Snap the seal into the groove. Figure 4.23 and Figure 4.24.

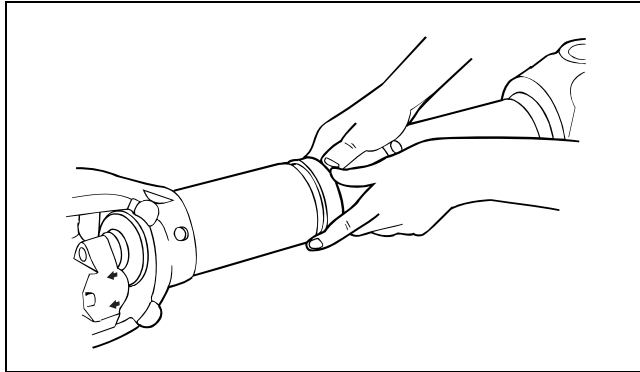

Figure 4.23

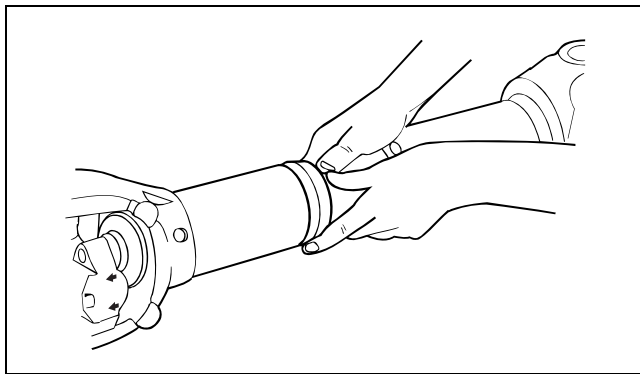

Figure 4.24

9. Use a brass or copper hammer to tap the shroud over the seal. Push together the driveline sections. Figure 4.25 and Figure 4.26.

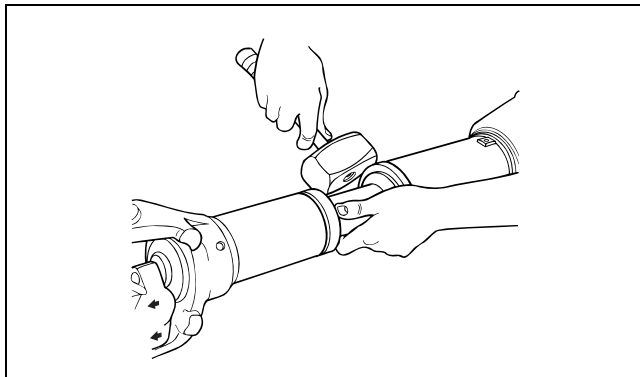

Figure 4.25

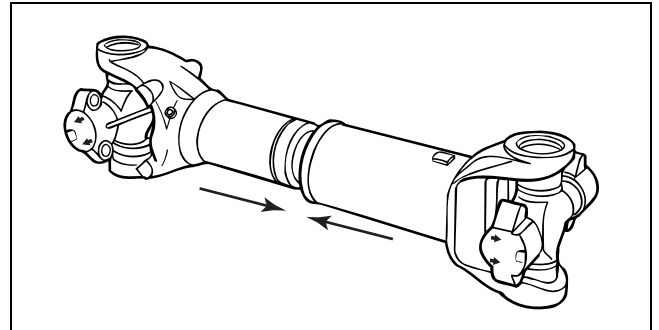

Figure 4.26

10. Use an Allen wrench to reinstall the grease plug. Figure 4.27.

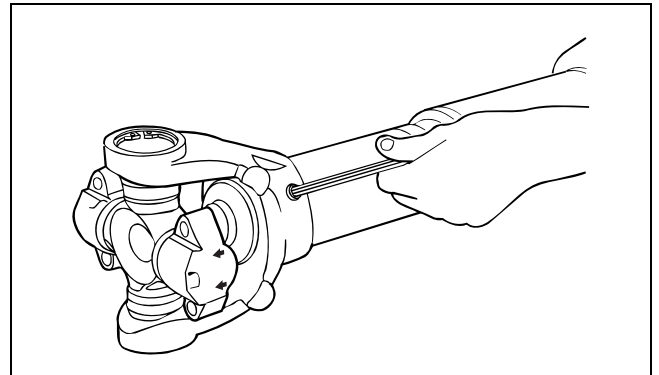

Figure 4.27

4 RPL Series Permalube™

Installation

Wing Bushings

⚠ WARNING

If you do not correctly install the universal joint and end yoke, the bushings will not correctly seat in the yoke, which can cause the capscrews that secure the universal joint to fatigue under normal operating conditions. Serious personal injury and damage to components can result.

⚠ CAUTION

A broken weld strap can cause a wing bushing to rotate. When a bushing rotates, it's possible to assemble it into the yoke backward. To ensure correct assembly and prevent damage to components, you must install both of the wing bushing's interference bosses away from the yoke.

The new design wing bushing has interference bosses on the bushing. The bosses interfere with the end yoke if you attempt to install the wing bushing incorrectly. You must install the interference bosses away from the yoke. Figure 4.28.

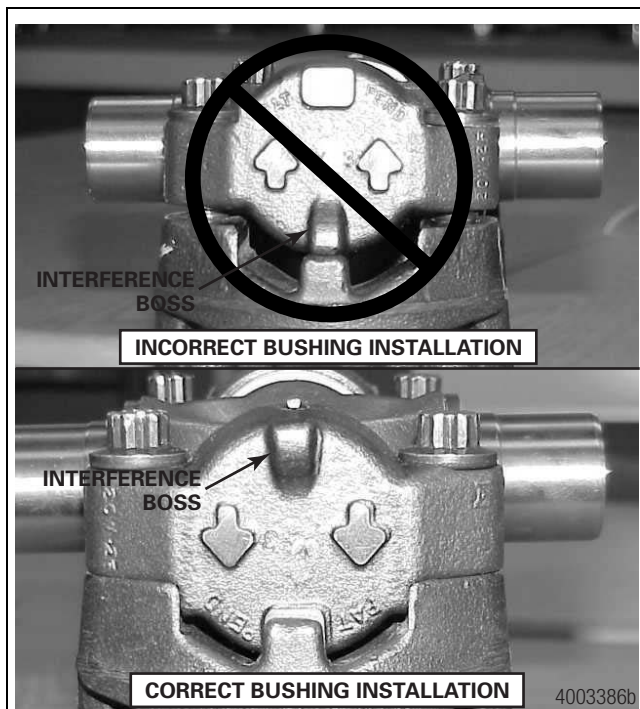

Figure 4.28

The previous design wing bushing did not have an interference boss. As a result, it was possible to insert the wing bushing into the yoke and install the pieces incorrectly. Figure 4.29.

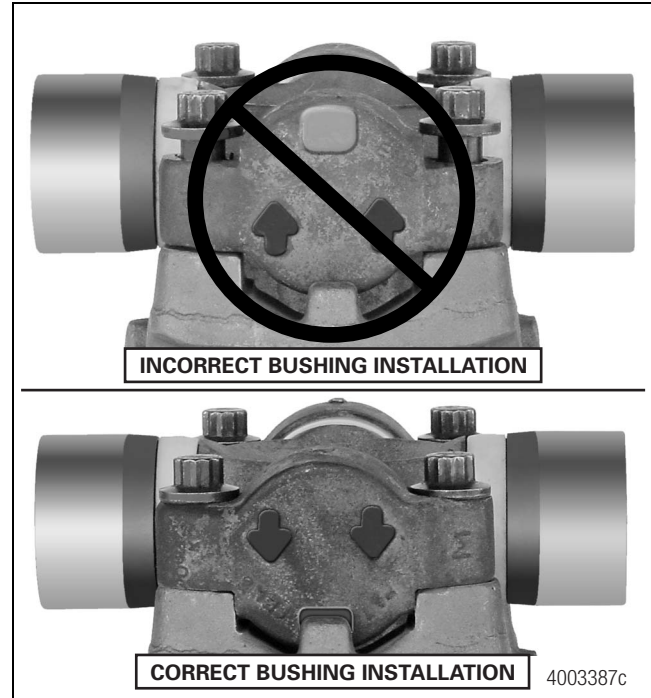

Figure 4.29

Universal Joint

⚠ CAUTION

Do not use grease or anti-seize compound in the yoke ear bores. Damage to components can result.

1. Clean dirt and contamination from the slip yoke and weld yoke ear bores. Figure 4.30.

4 RPL Series Permalube™

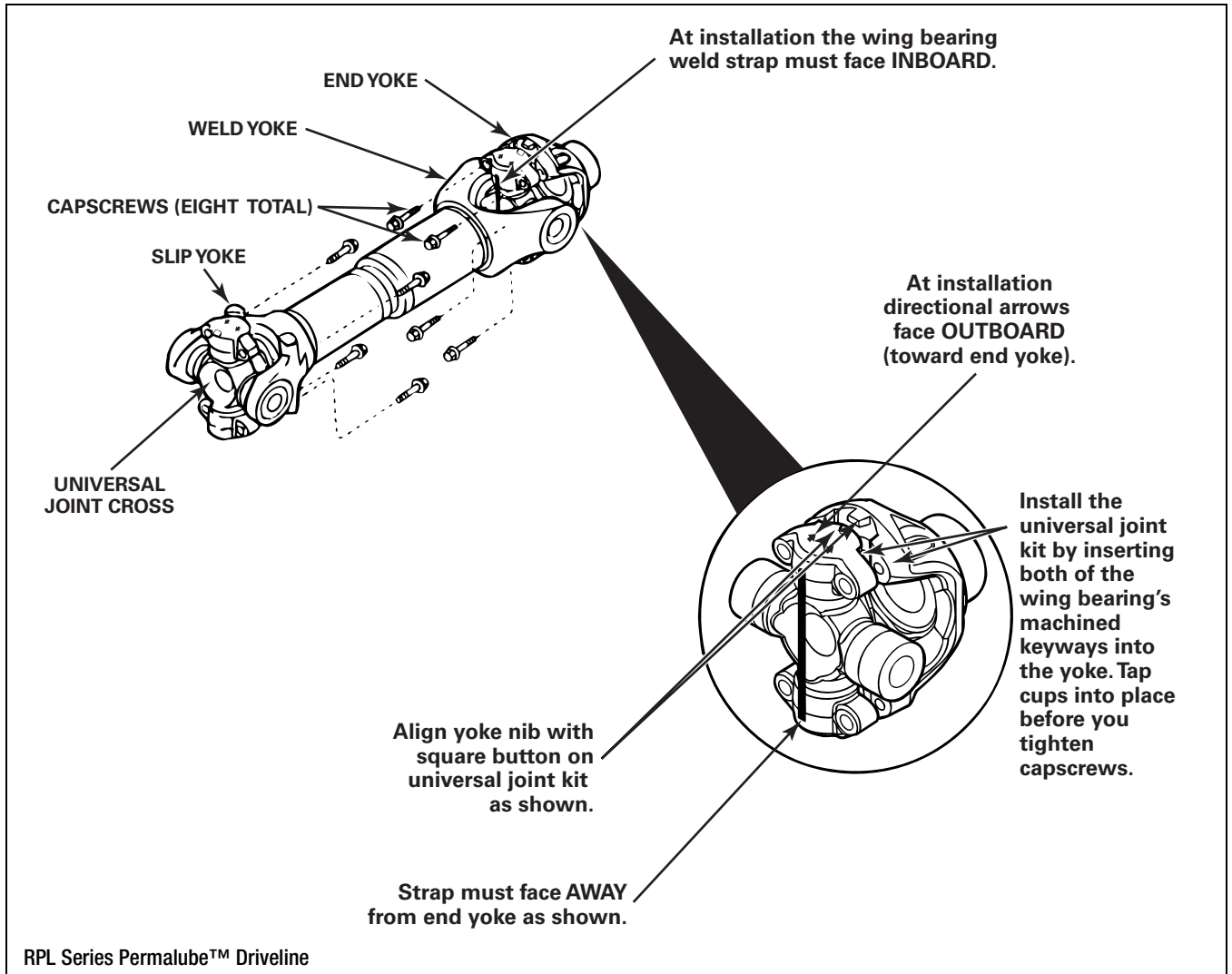

Figure 4.30

2. Install the universal joint into the yoke so that the wing bearing weld straps face **INBOARD** and the arrows point toward the end or coupling yokes. Figure 4.31.

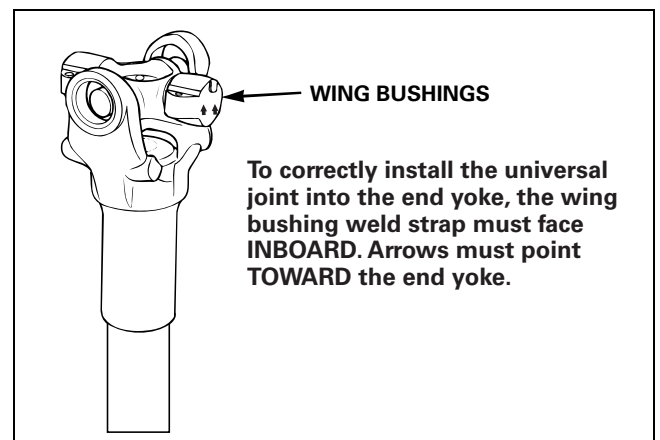

Figure 4.31

4 RPL Series Permalube™

⚠ CAUTION

The universal joint is supplied with the correct amount of grease. Do not apply additional grease to the joint. Do not use grease or anti-seize compound on the outside diameter of the cups, the cross bore holes of the yoke, or the yoke saddles. Damage to components can result.

NOTE: The deflector is preassembled onto the round bushing.

3. Verify that the plastic deflectors are attached to the round bushings. Figure 4.32.

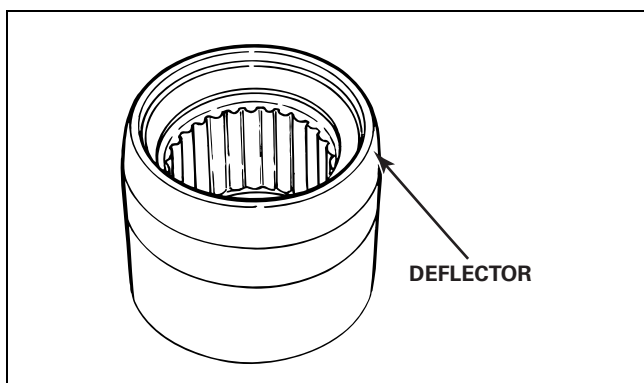

Figure 4.32

4. Position the first round bushing onto the trunnion by threading the cross trunnion through the yoke bore. Figure 4.33.

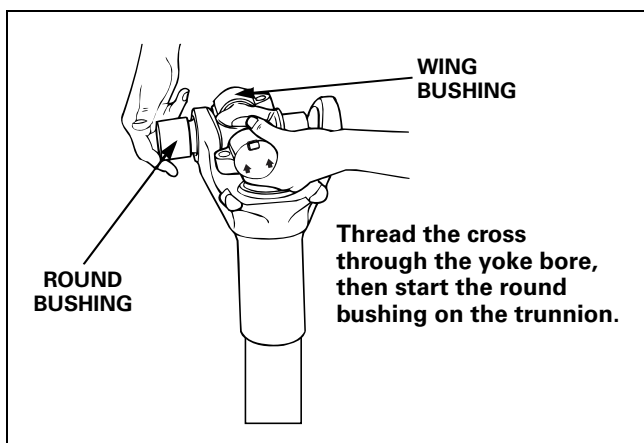

Figure 4.33

⚠ WARNING

Observe all warnings and cautions provided by the press manufacturer to avoid damage to components and serious personal injury.

⚠ CAUTION

Use an arbor press, universal joint press or yoke bearing cup installation tool to install the round bushing into the yoke. Do not use a hammer, which can loosen and damage components.

NOTE: The SPX Kent-Moore press yoke bearing cup installation tool number J-44516 has a positive stop for correct installation. Refer to the Service Notes page on the front inside cover of this manual for information to obtain this tool.

5. Use a press, yoke bearing cup installation tool (SPX Kent-Moore tool number J-44516) or universal joint press (Tiger Tool number 10707) to install the first round bushing slightly past the snap ring groove. When the bearing cup installation tool contacts the yoke, it is installed correctly. Figure 4.34, Figure 4.35 and Figure 4.36.

YOKE BEARING CUP INSTALLATION METHOD

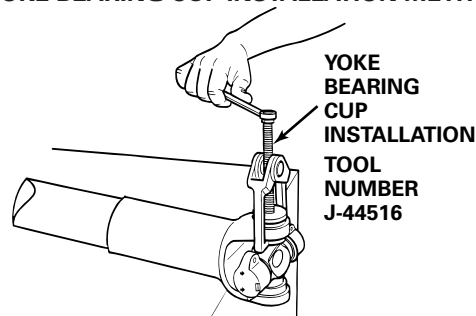

Installing the Bushing

Figure 4.34

UNIVERSAL JOINT PRESS METHOD

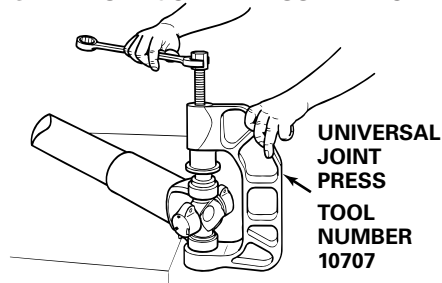

Installing the Bushing

Figure 4.35

4 RPL Series Permalube™

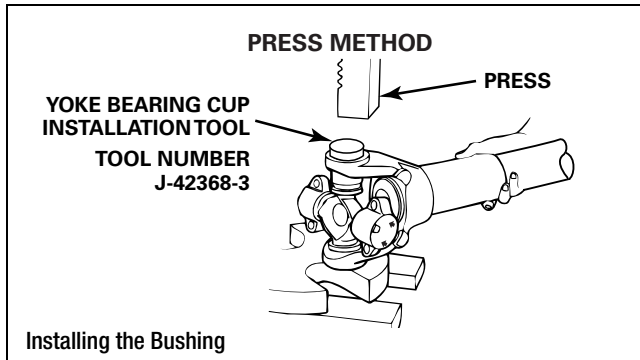

Figure 4.36

⚠ CAUTION

You must fully seat the snap ring into the snap ring groove to avoid damage to the driveline.

6. Use snap ring pliers to install the snap ring into the snap ring groove. Figure 4.37. Fully seat the snap ring.

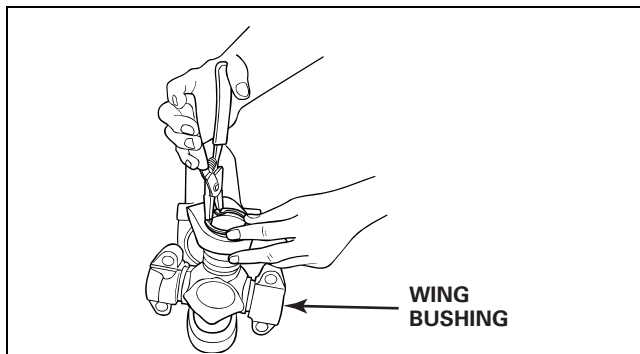

Figure 4.37

7. Position the second bushing onto the trunnion by threading the cross through the yoke bore as shown. Figure 4.38.

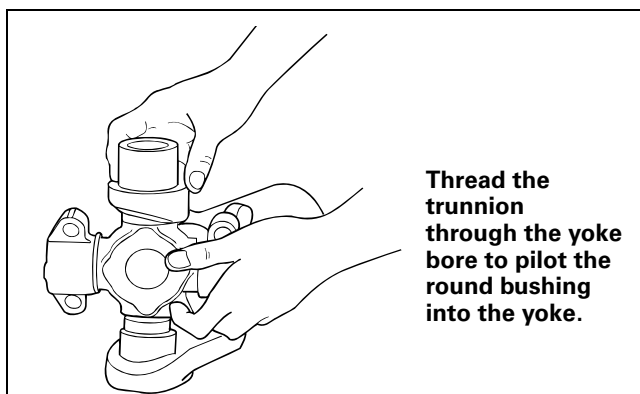

Figure 4.38

8. Use a press, yoke bearing cup installation tool (SPX Kent-Moore tool number J-44516) or universal joint press (Tiger Tool number 10707) to install the second round bushing slightly past the snap ring groove. Check that the bushing is aligned with the universal joint. Figure 4.34, Figure 4.35 and Figure 4.36.

⚠ CAUTION

You must fully seat the snap ring into the snap ring groove to avoid damage to the driveline.

9. Use snap ring pliers to install the second snap ring into the snap ring groove. Figure 4.39.

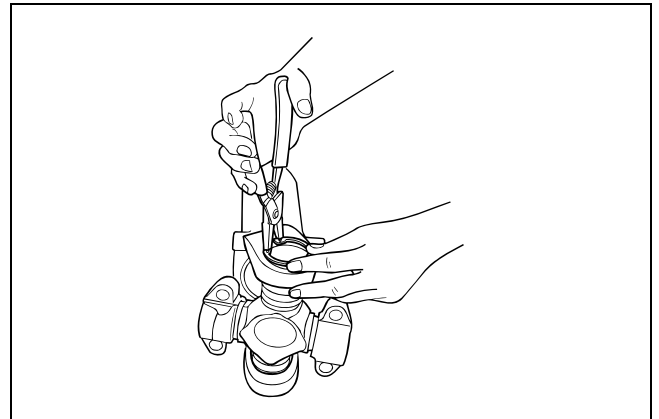

Figure 4.39

10. Strike the yoke ear with a brass or copper hammer to ensure that the universal joint moves freely. Figure 4.40.

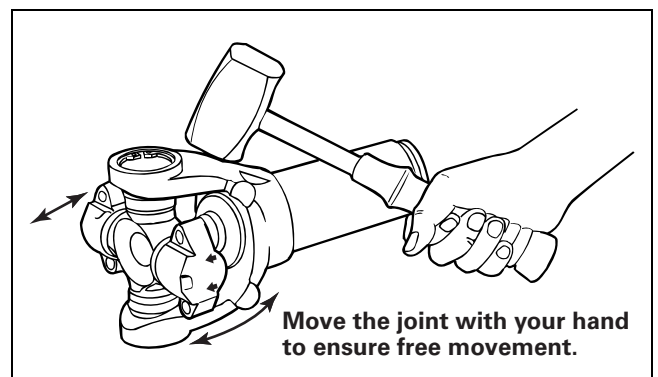

Figure 4.40

4 RPL Series Permalube™

Driveline

⚠ WARNING

If you do not correctly install the universal joint and end yoke, the bushings will not correctly seat in the yoke, which can cause the capscrews that secure the universal joint to fatigue under normal operating conditions. Serious personal injury and damage to components can result.

You must position the wing bushing's machined keyway against the machined keyway of the end yoke ears when you install a universal joint. Ensure that the arrows stamped on the wing bushing point TOWARD the end yoke, and the universal joint weld strap faces the driveline and AWAY from the yoke.

⚠ CAUTION

A broken weld strap can cause a wing bushing to rotate. When a bushing rotates, it's possible to assemble it into the yoke backward. To ensure correct assembly and prevent damage to components, you must insert both of the wing bushing's machined keyways into the yoke.

1. Before you install the capscrews, check that the universal joint is fully seated in the end yoke. The arrows on the wing bushing should point toward the coupling yoke. Figure 4.41.

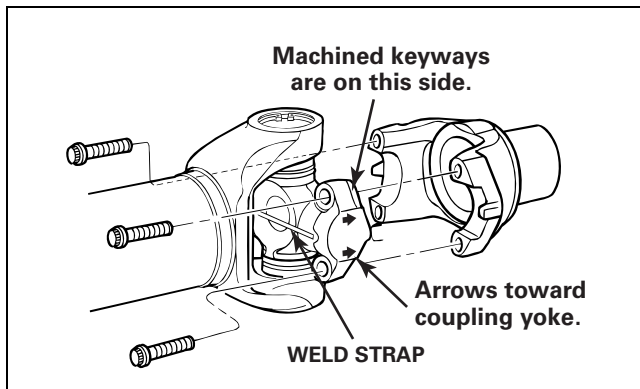

Figure 4.41

2. If necessary, tap the universal joint with a brass or copper hammer to ensure it is fully seated. Figure 4.42.

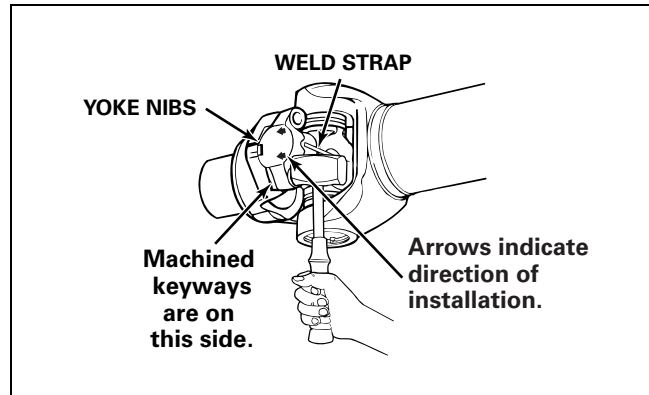

Figure 4.42

3. Install the new capscrews.
4. Use a torque wrench to alternately tighten the capscrews to 115-135 lb-ft (155-183 N•m). Figure 4.43. ⚠

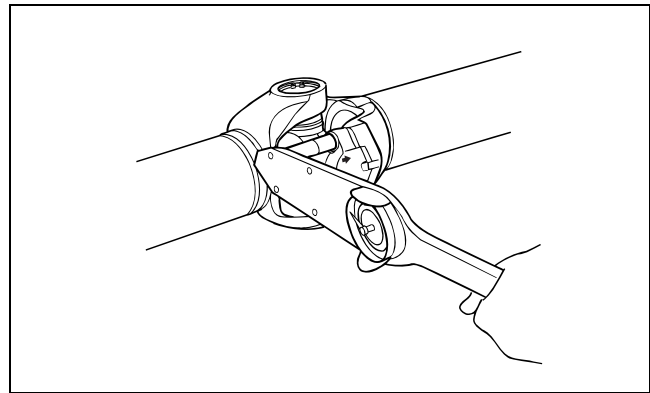

Figure 4.43

5 Full-Round

Hazard Alert Messages

Read and observe all Warning and Caution hazard alert messages in this publication. They provide information that can help prevent serious personal injury, damage to components, or both.

⚠ WARNING

To prevent serious eye injury, always wear safe eye protection when you perform vehicle maintenance or service.

Park the vehicle on a level surface. Block the wheels to prevent the vehicle from moving. Support the vehicle with safety stands. Do not work under a vehicle supported only by jacks. Jacks can slip and fall over. Serious personal injury and damage to components can result.

Removal

Driveline

1. Park the vehicle on a level surface. Block the wheels to keep the vehicle from moving. Raise the vehicle so that the area you will service is off the ground. Support the vehicle with safety stands.
2. Loosen and remove the capscrews from the end yoke bearing cups.
3. Remove the first bearing cup. If necessary, use a bearing puller to remove the bearing cup from the yoke bore. Figure 5.1.

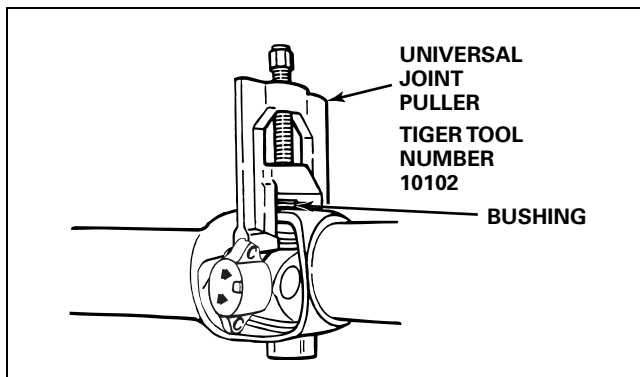

Figure 5.1

4. Remove the second bearing cup. Figure 5.2.

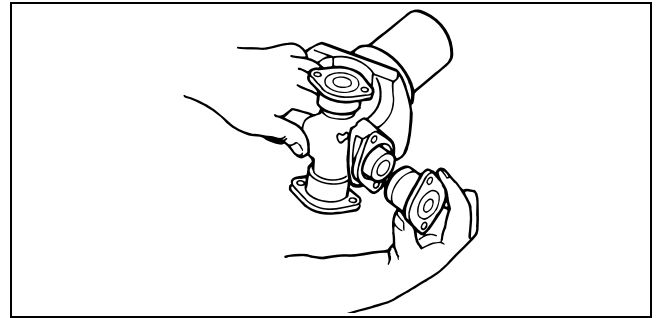

Figure 5.2

NOTE: Support the driveline when you remove it from the end yoke.

5. Slide the yoke to one side until you can work a trunnion free from the yoke bore.
6. Slide the yoke in the OPPOSITE direction while removing the universal joint from the end yoke.
7. Repeat Step 2 to Step 6 to separate the slip yoke end of the driveline.

Universal Joint

1. Loosen and remove the capscrews from the two remaining bearing cups on the yoke end of the driveline.
2. Remove the bearing cups. If necessary, use a commercial bearing puller to remove the bearing cups from the yoke bores.
3. Work the trunnions free of the yoke bores. Remove the universal joint cross from the weld yoke.
4. Repeat Step 1 to Step 3 to remove the universal joint cross from the slip yoke.

Installation

Universal Joint

⚠ WARNING

Use a brass or leather mallet for assembly and disassembly procedures. Do not hit steel parts with a steel hammer. Pieces of a part can break off and cause serious personal injury.

1. Install the universal joint cross into the yoke.
2. Install the two bearing cups through the yoke bores and onto the universal joint cross trunnions. If necessary, use a copper or brass hammer to tap the bearing caps until they are fully seated.

5 Full-Round

3. Hand-tighten the capscrews through the bearing cover plate and into the slip yoke.
4. Use a torque wrench to alternately tighten the capscrews to the correct specifications. Refer to Table B.
5. Repeat Step 1 to Step 3 to install the universal joint cross into the weld yoke.

Driveline

1. Wipe off the end yoke bearing bores. Insert the trunnion through the yoke bore.
2. Check the bearing cup to ensure that the needle bearings are in place. Replace the bearing cup when the needle bearings are missing or out of place.
3. Hold the cross. Use a copper or brass hammer to lightly tap the bearing cup completely into the yoke bore. Figure 5.3.

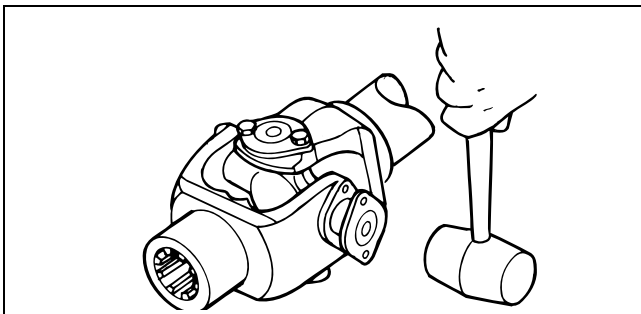

Figure 5.3

4. Align the cover plate holes and the yoke ear. Figure 5.4. Install the bearing cover plate flush against the milled surface of the yoke.

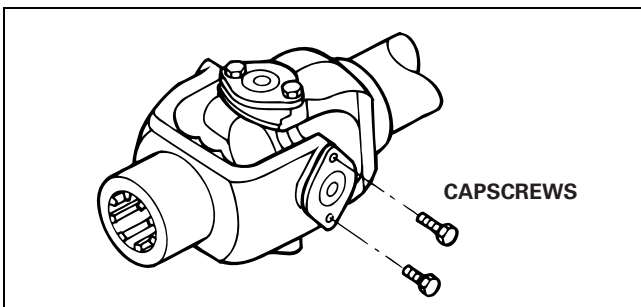

Figure 5.4

5. Install new capscrews and hand-tighten them through the bearing cover plate and into the yoke.

6. Repeat Step 2 to Step 5 to install the second bearing cup.
 - **If the cover plate will not seat flush against the yoke surface:** Remove each bearing cup from the yoke bore. Check the bottom of each bearing cup. If you find a needle bearing, replace the bearing cup.
7. Use a torque wrench to alternately tighten the capscrews to correct specifications. Refer to Table B. Figure 5.5.

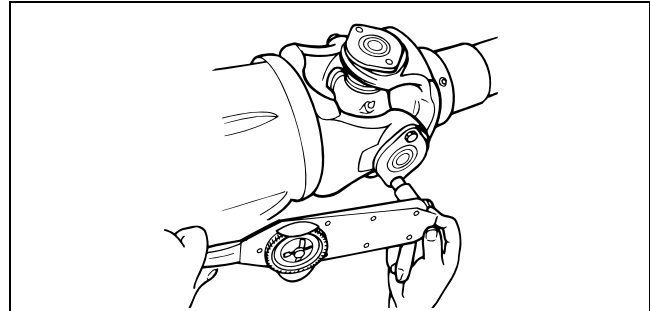
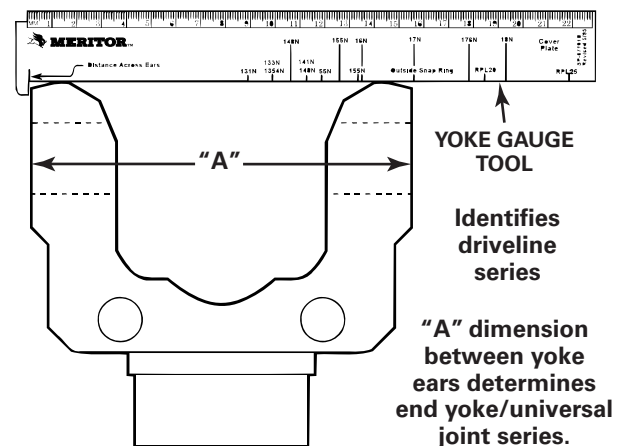

Figure 5.5

Table B: Torque Specifications — Full-Round

Driveline Series	"A" Inches (mm)	Thread Size Inches	Torque Specs lb-ft (N·m)
16N	5.31 (134.87)	5/16-24	26-35 (35-47)
17N	6.09 (154.69)	3/8-24	38-48 (51-65)
176N	7.00 (177.8)	3/8-24	38-48 (51-65)
18N	7.55 (191.77)	3/8-24	38-48 (51-65)



5 Full-Round

Lubrication

Universal Joint

After installation into the end yokes, lubricate the universal joints at the grease fitting until grease flows from the bearing cup seals on all four trunnions. Use Meritor grease specification O-634-B, NLGI Grade 2 with EP additive. Figure 5.6.

- **If grease does not purge from the seals:** Follow the steps below.

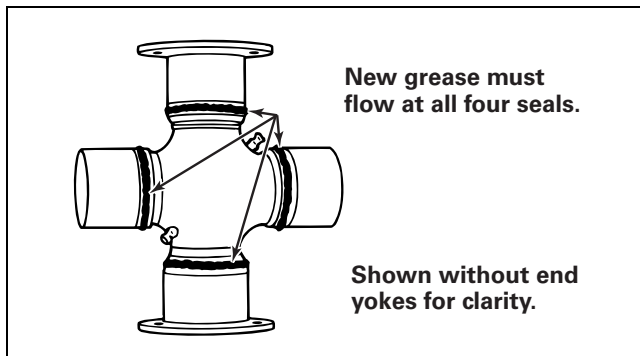
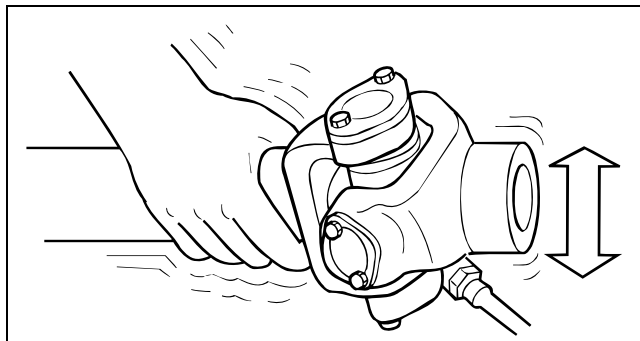



Figure 5.6

- A. Move the assembly UP-AND-DOWN or SIDE-TO-SIDE while you apply grease gun pressure. Figure 5.7.



- B. Loosen the bearing cup capscrews. Add grease until grease purges from the seals.
- **If grease still does not purge from all four trunnion seals:** Remove the universal joint and correct the problem.
 - **If you cannot determine the problem:** Replace the universal joint.
- C. Tighten the capscrews. Refer to Table B. 

Slip Yoke Splines

NOTE: When you lubricate a slip yoke, the splined shaft can be either fully extended or fully collapsed.

After installation, add Meritor specification O-634-B, NLGI Grade 2 with EP additive to the slip yoke grease fitting. Six to eight pumps or approximately one oz (28 grams) is sufficient to lubricate the splines. Figure 5.8.

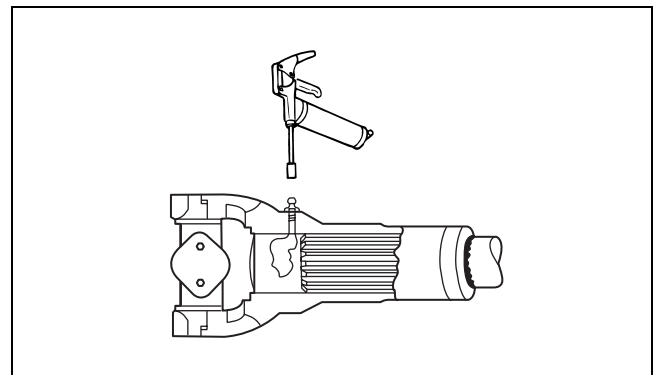

6 Wing-Style Permalube™

Hazard Alert Messages

Read and observe all Warning and Caution hazard alert messages in this publication. They provide information that can help prevent serious personal injury, damage to components, or both.

⚠ WARNING

To prevent serious eye injury, always wear safe eye protection when you perform vehicle maintenance or service.

Use a brass or copper hammer to seat bearing cups into yoke bores. Do not use a steel hammer, which can cause the yoke or bearing cup to crack and break off. Serious personal injury and damage to the trunnion, yoke or bearing cup can result.

Only service a driveline when the engine is OFF. A rotating driveline can cause serious personal injury.

Removal

Driveline

⚠ WARNING

Park the vehicle on a level surface. Block the wheels to prevent the vehicle from moving. Support the vehicle with safety stands. Do not work under a vehicle supported only by jacks. Jacks can slip and fall over. Serious personal injury and damage to components can result.

1. Park the vehicle on a level surface. Block the wheels to keep the vehicle from moving. Raise the vehicle so that the area you will service is off the ground. Support the vehicle with safety stands.
2. Loosen and remove the four capscrews from the weld yoke end of the driveline. Support the weld yoke end, and separate it from the end yoke.
3. Loosen and remove the four capscrews from the slip yoke end of the driveline. Support the slip yoke end, and separate it from the vehicle.

Universal Joint

NOTE: Wing-style universal joints are permanently assembled. Welded steel straps attach the bearing cups to the trunnion to help ensure that the universal joint fits correctly into the mating yokes. Do not cut or remove the welded straps from the universal joint kits.

1. Loosen and remove the four capscrews retaining the universal joint cross to the weld yoke.

2. Loosen and remove the four capscrews retaining the universal joint cross to the slip yoke. Figure 6.1.

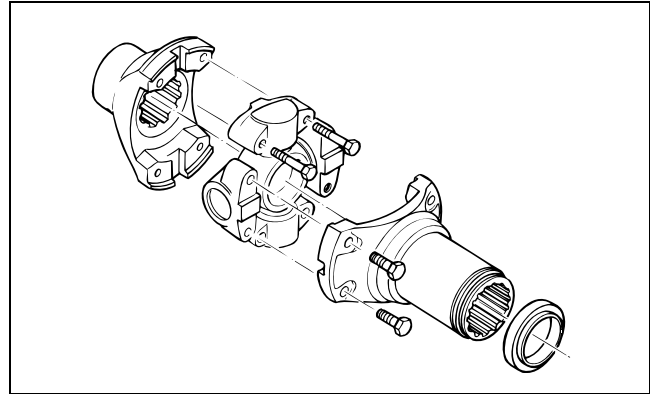

Figure 6.1

Installation

Universal Joint

1. Tap the bearing cups lightly with a brass or copper hammer to seat the bearing cups into the yoke pilot.

NOTE: Capscrews have a “lock patch” and can be hand-tightened only two or three threads.

2. Install new capscrews and lock washers. Figure 6.2. Refer to Table C.
3. Hand-tighten the capscrews to the yoke pilot.
4. Use a torque wrench to alternately tighten the capscrews to correct specifications. Figure 6.2. Refer to Table C. **ⓘ**

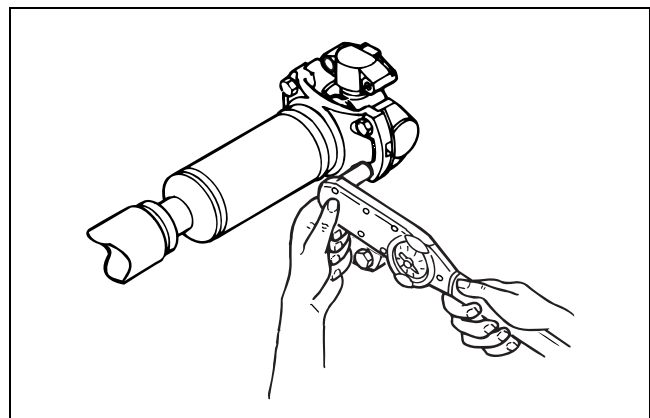

Figure 6.2

6 Wing-Style Permalube™

Table C: Replacement Parts and Torque Specifications

Drivelines	Name	Description	Torque Specs lb-ft (N•m)
Wing-Style Permalube™	Capscrew	1/2-20 x 2-1/2"	115-135
		1/2-20 x 1-1/2"	(155-183)
		3/8-24	40-55 (54-74)
	Jam Nut	1/2" H.D.	63-83 (85-112)

Driveline

NOTE: You may install either the slip yoke or weld yoke driveline end first when following the instructions below. After you install one driveline end, repeat these steps to install the opposite end of the driveline.

1. Support the driveline.
2. Tap the bearing cups lightly with a brass or copper hammer to seat the bearing cups into the end yoke.
3. Install the four capscrews and lock washers that attach the universal cross to the end yoke. Figure 6.1.

NOTE: Capscrews have a "lock patch" and can be hand-tightened only two or three threads.

4. Hand-tighten the capscrews to the yoke pilot.
5. Use a torque wrench to alternately tighten the capscrews to Meritor's driveline torque specifications. Refer to Table C and Figure 6.2. 
6. Repeat Step 1 to Step 5 to install the opposite driveline end.

Lubrication

Universal Joint

Wing-style universal joints can be greaseable or non-greaseable. Non-greaseable Permalube™ universal joints do not have grease fittings.

Wing-Style Permalube™ Universal Joints (Non-Greaseable)

Wing-Style Permalube™ universal joints are permanently lubricated with grease developed with specific wear and temperature properties. However, you must periodically lubricate the slip yoke splines. Refer to Table G and Slip Yoke Splines for specifications and maintenance procedures.

Wing-Style Universal Joints (Greaseable)

Wing-style greaseable universal joints have grease fittings and are not permanently lubricated. Refer to Table G. To lubricate greaseable universal joints, follow the procedures provided for the Full-Round driveline in Section 5.

Slip Yoke Splines

CAUTION

Do not remove the grease plugs from the cross in an attempt to add additional grease. Damage to the universal joint can result.

NOTE: When you lubricate a slip yoke, the splined shaft can be either fully extended or fully collapsed.

The slip yoke splines are not permanently lubricated and must be greased periodically.

Add Meritor specification O-634-B, NLGI Grade 2 with EP additive to the slip yoke grease fitting. Six to eight pumps or approximately one oz (28 grams) is sufficient to lube the splines. Figure 6.3.

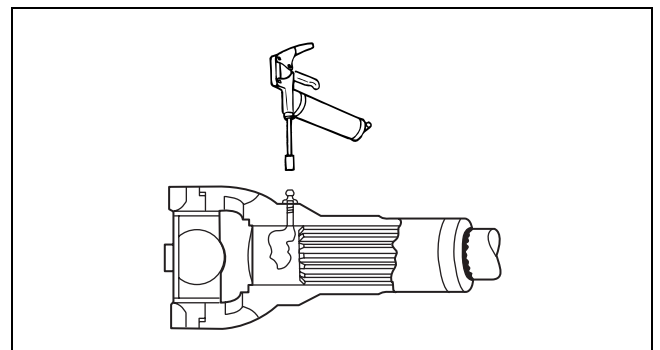

Figure 6.3

7 Easy Service™

Hazard Alert Messages

Read and observe all Warning and Caution hazard alert messages in this publication. They provide information that can help prevent serious personal injury, damage to components, or both.

WARNING

To prevent serious eye injury, always wear safe eye protection when you perform vehicle maintenance or service.

Removal

Driveline

WARNING

Only service a driveline when the engine is OFF. A rotating driveline can cause serious personal injury.

Park the vehicle on a level surface. Block the wheels to prevent the vehicle from moving. Support the vehicle with safety stands. Do not work under a vehicle supported only by jacks. Jacks can slip and fall over. Serious personal injury and damage to components can result.

1. Park the vehicle on a level surface. Block the wheels to keep the vehicle from moving. Raise the vehicle so that the area you will service is off the ground. Support the vehicle with safety stands.
2. Loosen and remove the capscrews and bearing straps from the weld yoke end of the driveline. Support the weld yoke end and separate it from the end yoke.
3. Loosen and remove the capscrews and bearing straps from the slip yoke end of the driveline. Support the slip yoke end and separate it from the vehicle.

Universal Joint

1. Loosen and remove the capscrews from the two bearing cups on the weld yoke end of the driveline.
2. Remove the bearing cups. If necessary, use a bearing puller to remove the bearing cups from the yoke bores.
3. Work the trunnions free of the yoke bores. Remove the universal joint cross from the weld yoke.
4. Repeat Step 1 to Step 3 to remove the universal joint cross from the slip yoke.

Installation

Universal Joint

WARNING

Use a brass or leather mallet for assembly and disassembly procedures. Do not hit steel parts with a steel hammer. Pieces of a part can break off and cause serious personal injury.

CAUTION

Do not seat the bearing cups into the yoke saddle by tightening down the bearing straps and capscrews. Uneven load distribution, yoke bearing rotation, and damage to the straps and yoke nibs can result.

NOTE: To help ensure maximum driveline performance, do not apply lubricant, grease, anti-seize compound, etc., to the yoke saddles.

1. Install the universal joint cross into the yoke. Always use new bolts and straps.

NOTE: For easier installation, do not remove the wire that fastens the bearing cups to the universal joint trunnion.

2. Install the bearing cups through the yoke bores and onto the universal joint cross trunnions.
3. Tap the bearing cup lightly with a leather or rubber mallet to seat the bearing cups into the yoke saddle.

NOTE: Capscrews have a “lock patch” and can be hand-tightened only two or three threads.

4. Hand-tighten the bearing capscrews. Use a torque wrench to tighten the capscrews to the specified torque. Refer to Table D.



Driveline

1. Wipe off the yoke saddle.
2. Support the driveline. Install the bearing straps and capscrews onto the slip yoke end of the driveline.

NOTE: Capscrews have a “lock patch” and can be hand-tightened only two or three threads.

3. Hand-tighten the capscrews through the bearing strap into the yoke.

7 Easy Service™

- Use a torque wrench to alternately tighten the capscrews to Meritor's driveline torque specification. Refer to Table D. Figure 7.1. 
- Repeat Step 1 through Step 3 to attach the weld yoke end of the driveline to the vehicle.

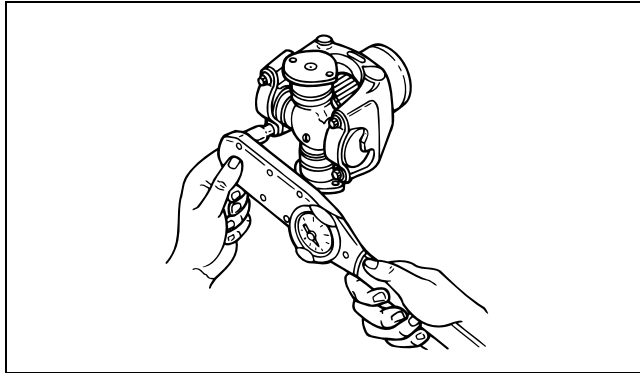
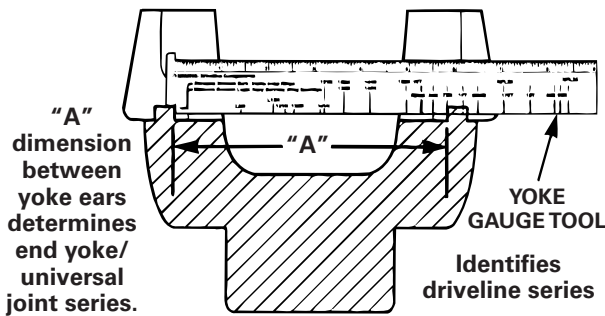

Figure 7.1

Table D: Torque Specifications — Easy Service™

Driveline Series	"A" Inches (mm)	Thread Size Inches	Torque Specs lb-ft (N•m)
155T	4.97 (126.24)	3/8-24	40-60 (54-81)
16T	5.31 (134.87)	3/8-24	45-60 (61-81)
17T	6.19 (157.23)	1/2-20	115-135 (155-183)
176T	7.09 (180.08)	1/2-20	115-135 (155-183)
18T	7.63 (193.8)	1/2-20	115-135 (155-183)



Lubrication

Universal Joint

Lubricate the universal joints at the grease fitting until grease flows from the bearing cup seals on all four trunnions. Use a grease that meets Meritor specification O-634-B, NLGI Grade 2 with EP additive. Figure 7.2.

- If grease does not purge from all four trunnion seals:** Follow the steps below.
 - Move the assembly UP-AND-DOWN or SIDE-TO-SIDE while you apply grease gun pressure. Figure 7.3.
 - Loosen the bearing cup capscrews. Add grease until grease purges from the four seals.
 - Tighten the bearing cup capscrews after grease purges.
- If grease still does not purge from all four trunnion seals:** Remove the universal joint and correct the problem. If you cannot, replace the universal joint.

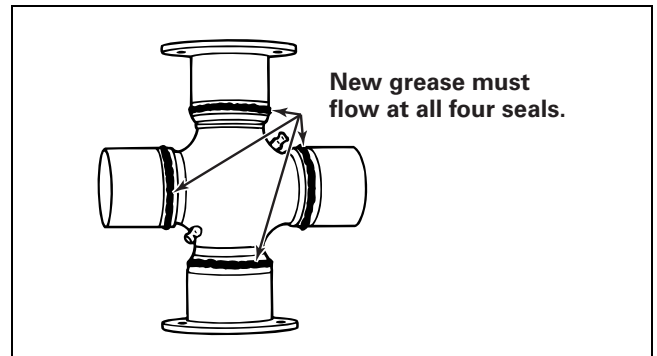

Figure 7.2

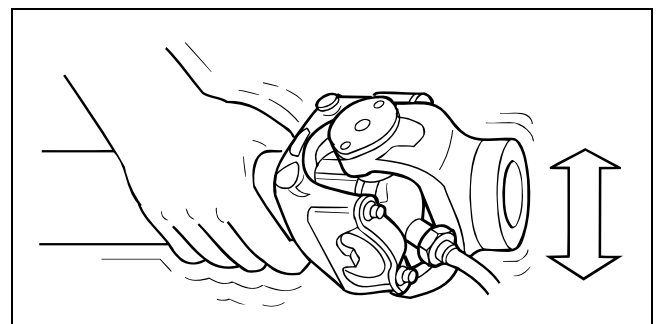

Figure 7.3

7 Easy Service™

Slip Yoke Splines

NOTE: When you lubricate a slip yoke, the splined shaft can be either fully extended or fully collapsed.

Add a grease that meets Meritor specification O-634-B, NLGI Grade 2 with EP additive, to the slip yoke grease fitting. Six to eight pumps or approximately one oz (28 grams) is sufficient to lube the splines. Figure 7.4.

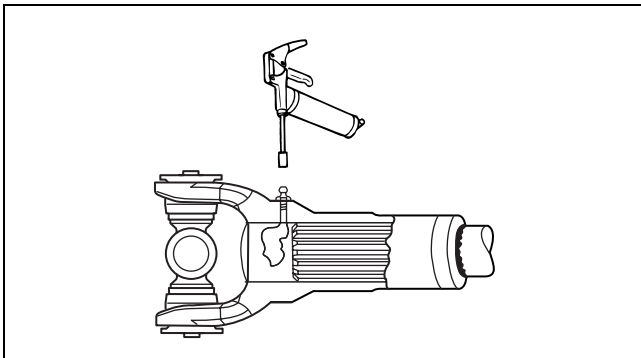

Figure 7.4

8 155R Series Slip Drive Shaft Assembly

Description

155R Series Drive Shaft Configurations

The 155R Series offers two drive shaft configurations:

- Standard slip
- Outboard slip
- Both configurations are available in two-piece and three-piece drivelines.

Standard Slip Drive Shaft

With the standard slip drive shaft assembly, the splined shaft points forward in the vehicle. Figure 8.1.

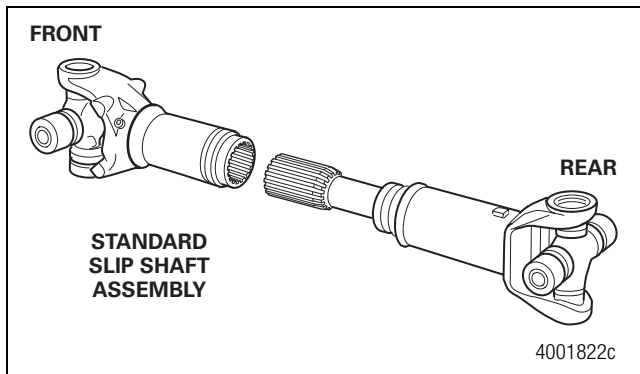

Figure 8.1

Outboard Slip Drive Shaft Assembly

The splined shaft points to the rear of the vehicle with the outboard slip drive shaft assembly. A center bearing supports the forward section of the drive shaft assembly. Figure 8.2.

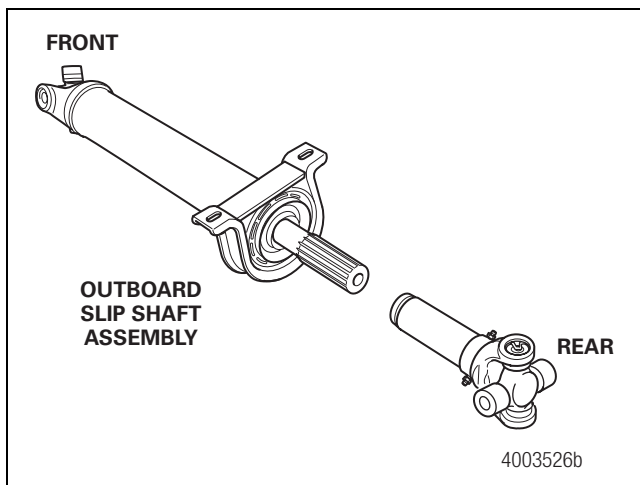

Figure 8.2

8 155R Series Slip Drive Shaft Assembly

Two-Piece Drivelines

A two-piece driveline is comprised of a non-slip coupling shaft followed by either a standard slip or reverse slip drive shaft assembly. The non-slip coupling shaft is always positioned in front of the slip shaft. Figure 8.3 and Figure 8.4.

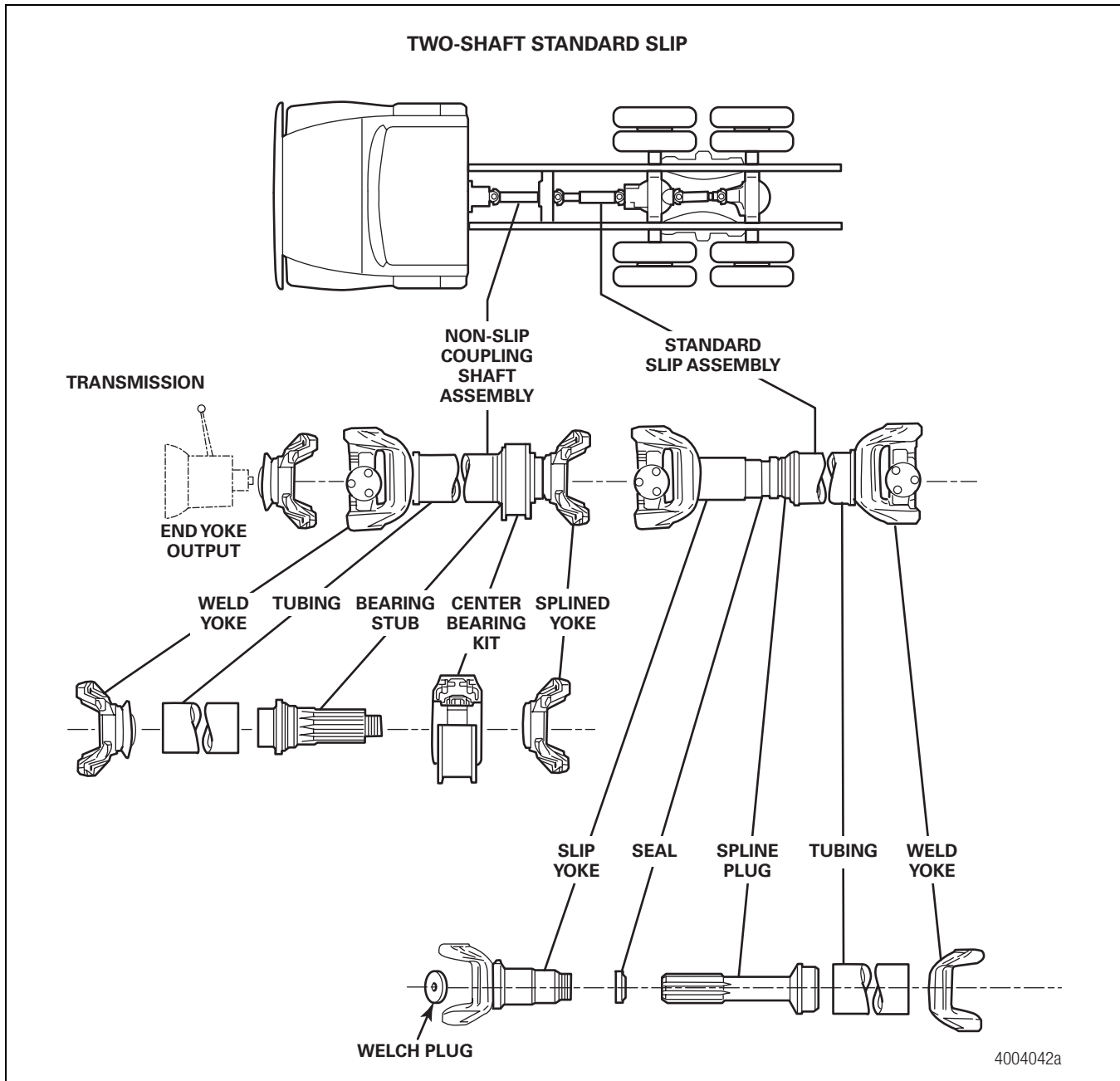

Figure 8.3

8 155R Series Slip Drive Shaft Assembly

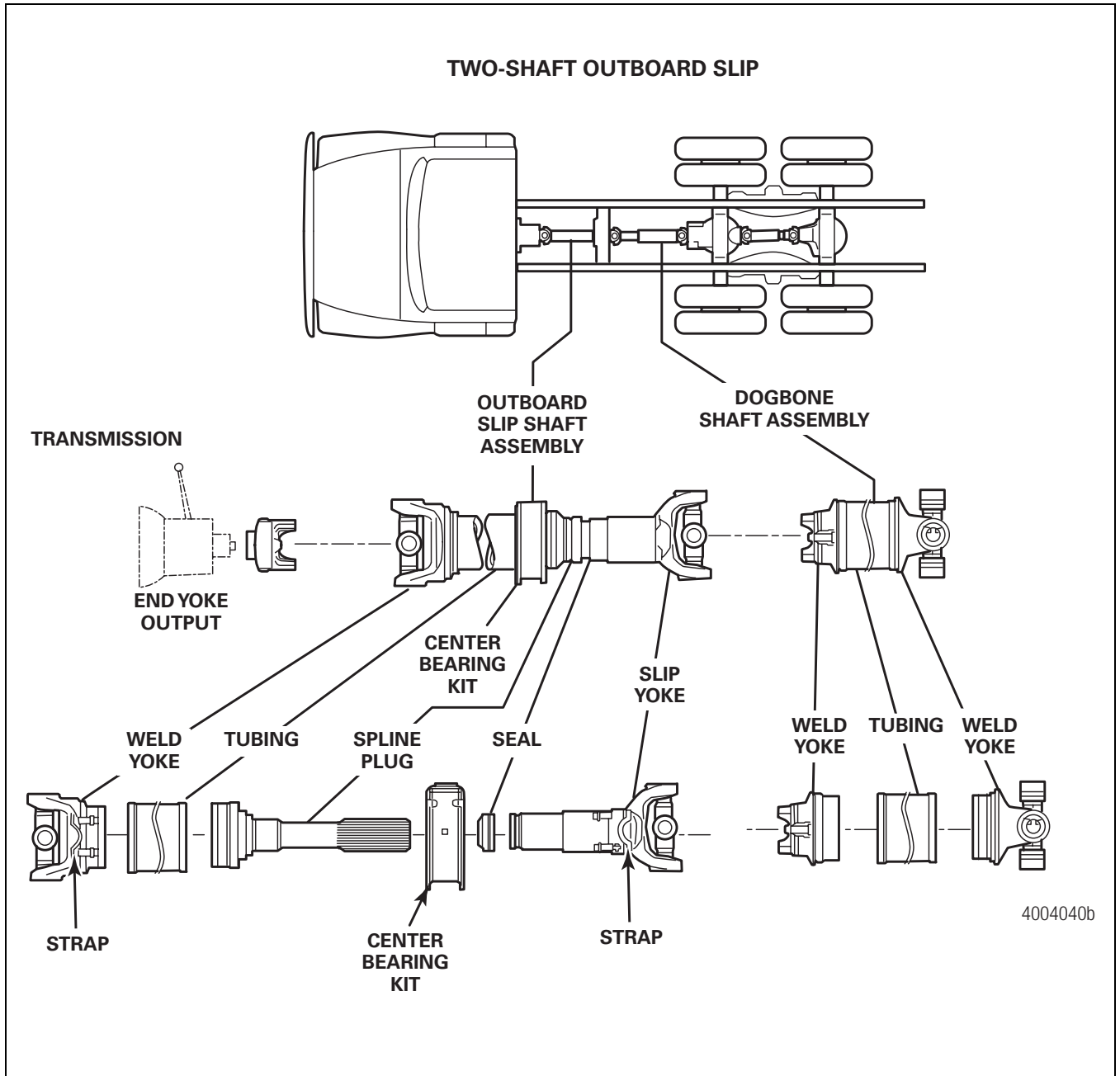

Figure 8.4

8 155R Series Slip Drive Shaft Assembly

Three-Piece Drivelines

A three-piece driveline is comprised of two non-slip coupling shafts followed by either a standard slip or reverse slip drive shaft assembly. The non-slip coupling shafts are always positioned in front of the slip shaft. Figure 8.5 and Figure 8.6.

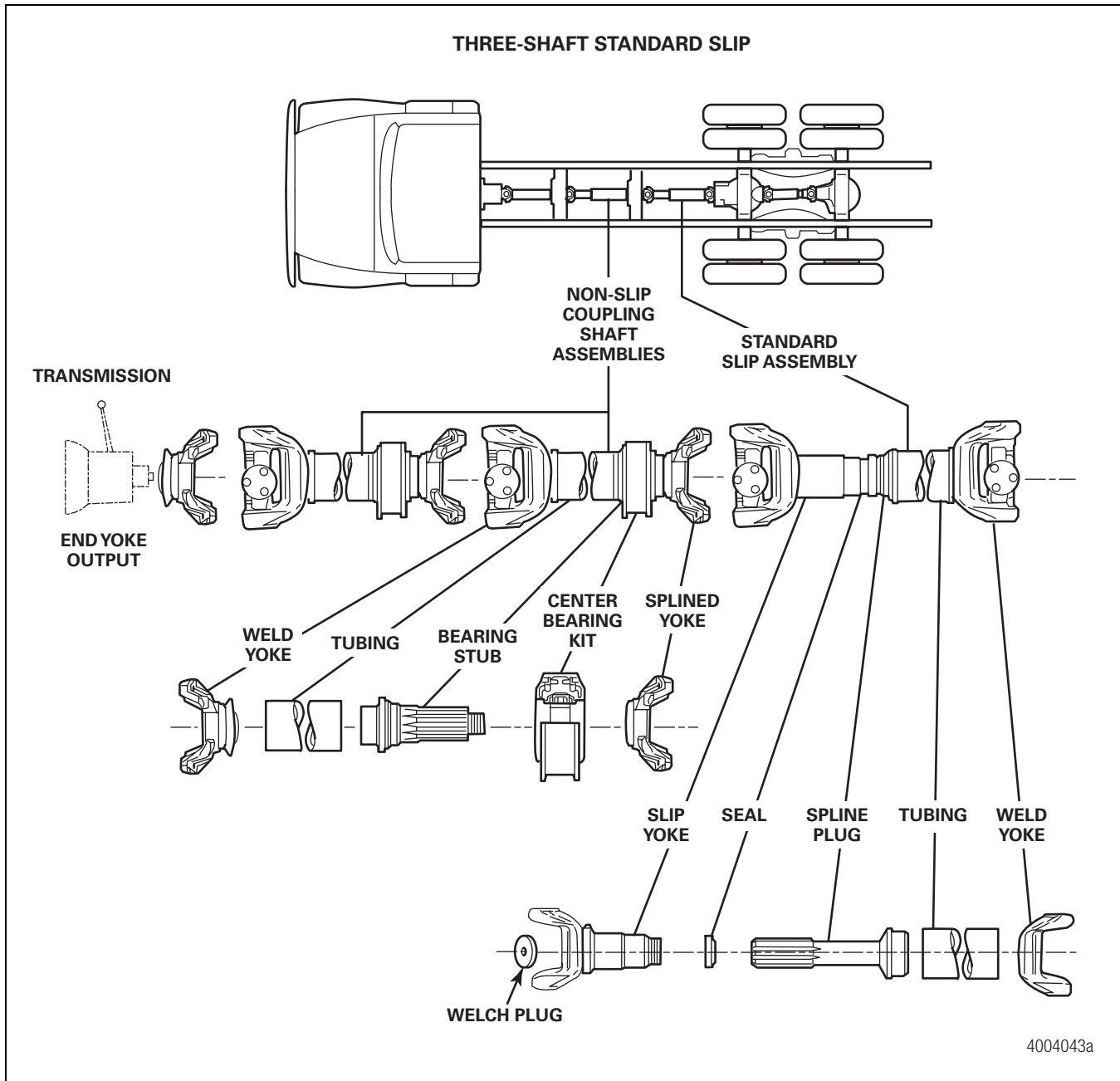

Figure 8.5

8 155R Series Slip Drive Shaft Assembly

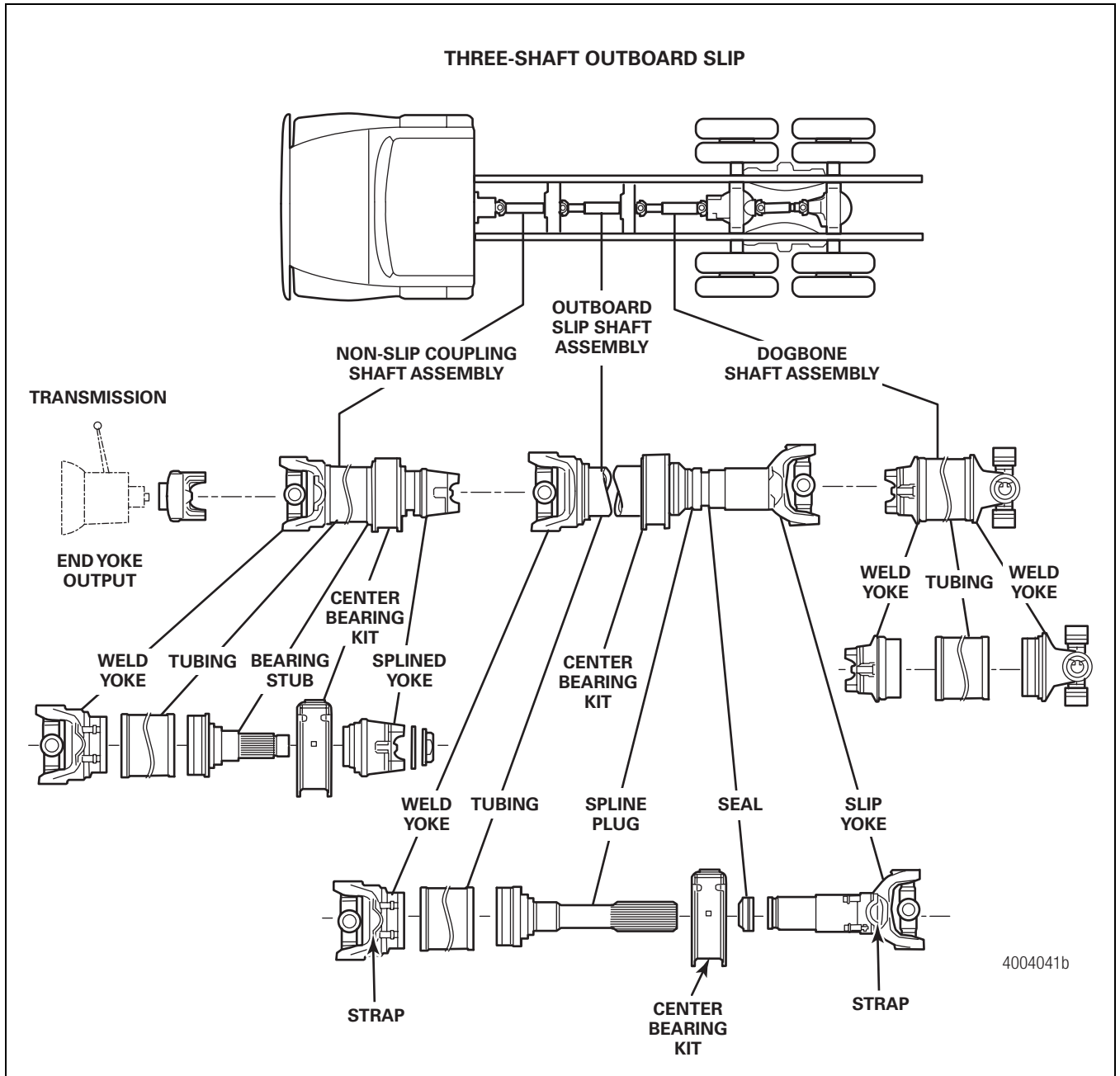

Figure 8.6

8 155R Series Slip Drive Shaft Assembly

Hazard Alert Messages

Read and observe all Warning and Caution hazard alert messages in this publication. They provide information that can help prevent serious personal injury, damage to components, or both.

⚠ WARNING

To prevent serious eye injury, always wear safe eye protection when you perform vehicle maintenance or service.

Removal

Driveline

⚠ WARNING

Only service a driveline when the engine is OFF. A rotating driveline can cause serious personal injury.

Park the vehicle on a level surface. Block the wheels to prevent the vehicle from moving. Support the vehicle with safety stands. Do not work under a vehicle supported only by jacks. Jacks can slip and fall over. Serious personal injury and damage to components can result.

1. Park the vehicle on a level surface. Block the wheels to keep the vehicle from moving. Raise the vehicle so that the area you will service is off the ground. Support the vehicle with safety stands.
2. Loosen and remove the capscrews and bearing straps from the weld yoke end of the driveline. Support the weld yoke end and separate it from the end yoke.
3. Loosen and remove the capscrews and bearing straps from the slip yoke end of the driveline. Support the slip yoke end and separate it from the vehicle.

Universal Joint

Snap Ring

NOTE: Refer to the Service Notes page on the front inside cover of this manual for information on how to obtain SPX Kent-Moore tools.

1. Use snap ring pliers to remove the snap rings. Figure 8.7.



Figure 8.7

2. If necessary, use a brass drift and lightly tap the center of the bushing to assist in snap ring removal. Figure 8.8.

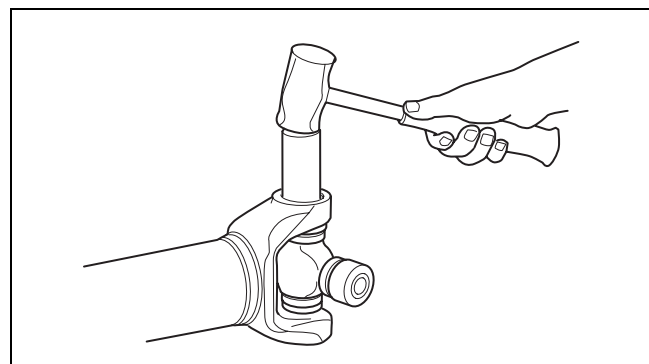

Figure 8.8

3. Repeat the previous steps on the other side of the yoke.

Round Bushings

NOTE: Use only the appropriate tools to remove the round bushings. Do not use the SPX Kent-Moore yoke bearing cup installation tool (number J-44516) to remove the round bushings. Damage to the tool can result.

Use one of the following procedures to remove and install round bushings.

- Press, bridge and bearing cup receiver
- Universal joint press
- Universal joint puller

8 155R Series Slip Drive Shaft Assembly

⚠ WARNING

Observe all warnings and cautions provided by the press manufacturer to avoid damage to components and serious personal injury.

Using a Press, Bridge and Bearing Cup Receiver

1. Place the universal joint in a suitable press bridge and bearing cup bushing receiver. Figure 8.9. Refer to the Service Notes page on the front inside cover of this manual for information to obtain these tools.

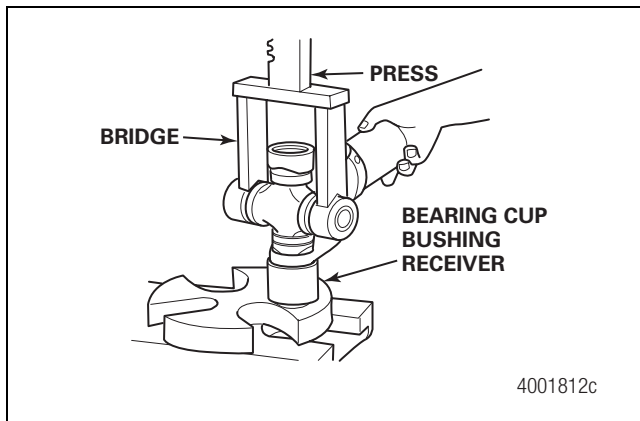

Figure 8.9

2. Press DOWN until the first round bushing loosens. Figure 8.9. Remove the round bushing. Figure 8.10.

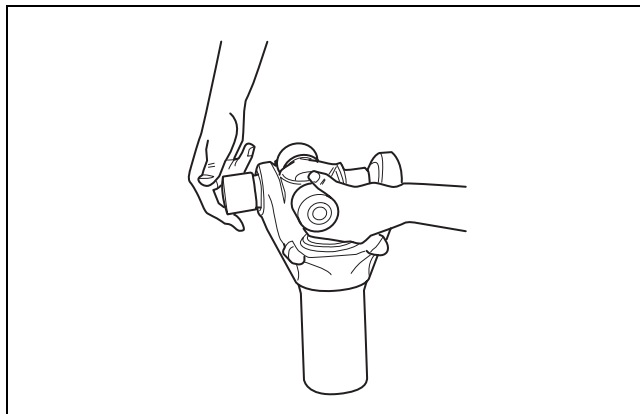

Figure 8.10

3. Rotate the shaft 180 degrees. Repeat the procedure for the opposite side of the universal joint. Figure 8.11.

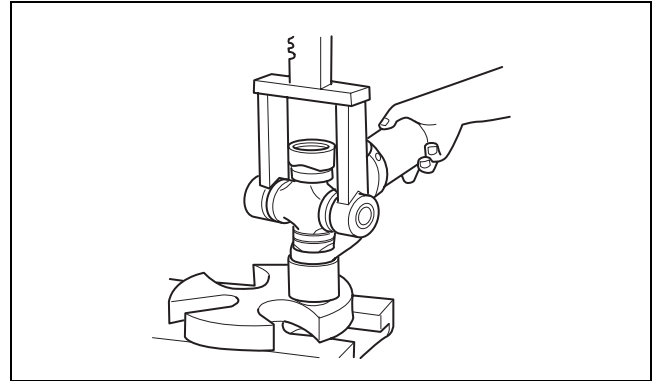

Figure 8.11

4. Remove the universal joint from the yoke.

Using a Universal Joint Press

1. Position the universal joint in a suitable universal joint press. Figure 8.12. Refer to the Service Notes page on the front inside cover of this manual for information to obtain this tool.

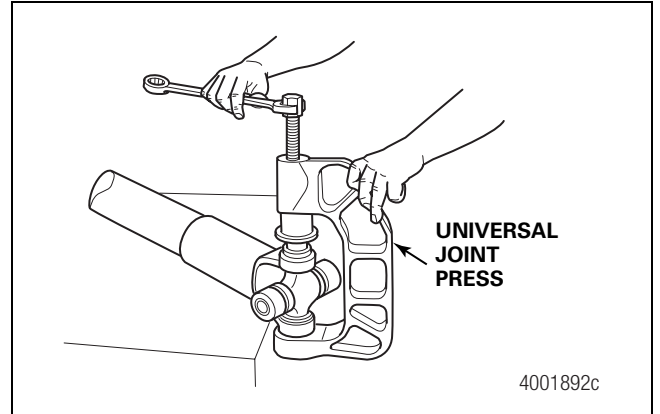

Figure 8.12

2. Turn the screw on the tool CLOCKWISE until the bushing loosens.
3. Turn the screw on the tool COUNTERCLOCKWISE until you can remove the bushing.
4. Turn over the universal joint. Repeat the procedure for the opposite side of the universal joint.
5. Remove the universal joint from the yoke.

8 155R Series Slip Drive Shaft Assembly

Using a Universal Joint Puller

1. Position the universal joint in a suitable universal joint puller. Refer to the Service Notes page on the front inside cover of this manual for information to obtain this tool. Figure 8.13.

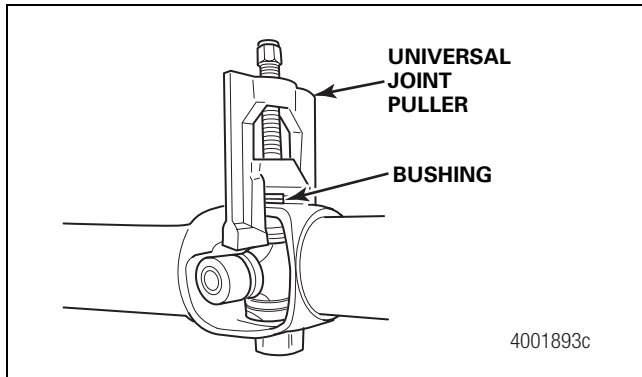

Figure 8.13

2. Turn the screw on the tool CLOCKWISE until the bushing loosens.
3. Turn the screw on the tool COUNTERCLOCKWISE and remove the bushing.
4. Turn over the universal joint. Repeat the procedure for the opposite side of the universal joint.
5. Remove the universal joint from the yoke.

Disassembly

Standard Slip Configuration

1. Mark the slip yoke and slip shaft sections to ensure that you reassemble them into their original positions. Figure 8.14.

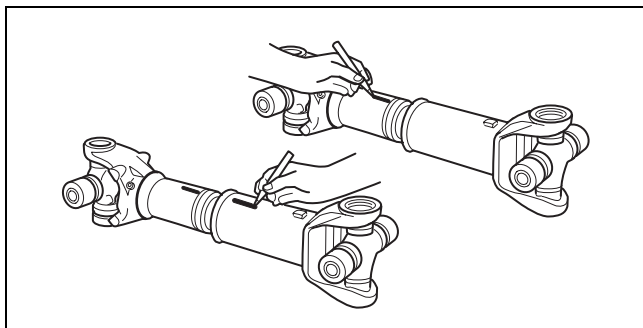

Figure 8.14

2. Pull the slip yoke and slip shaft sections apart. Figure 8.15.

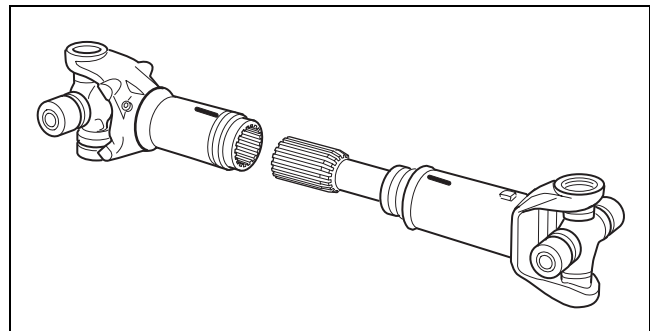

Figure 8.15

3. Remove the seal from the slip shaft. Figure 8.16.

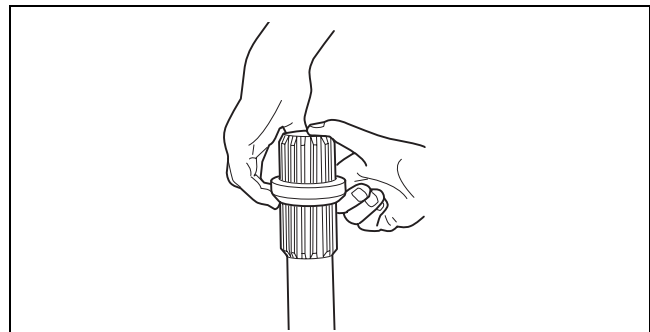

Figure 8.16

Outboard Slip Configuration

1. Mark the slip yoke and slip shaft sections to ensure that you reassemble them into their original positions. Figure 8.17.

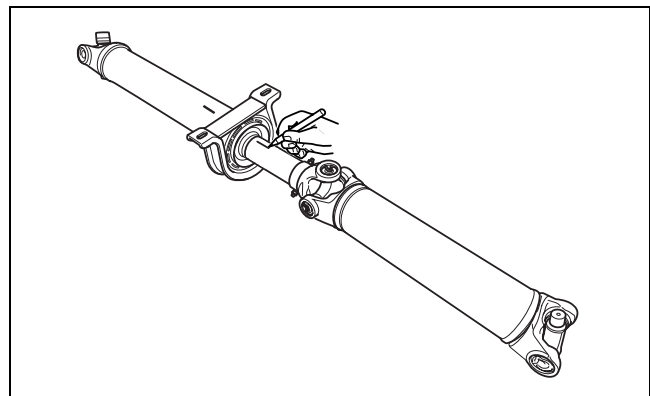

Figure 8.17

8 155R Series Slip Drive Shaft Assembly

2. Pull the slip yoke and slip shaft sections apart. Figure 8.18.

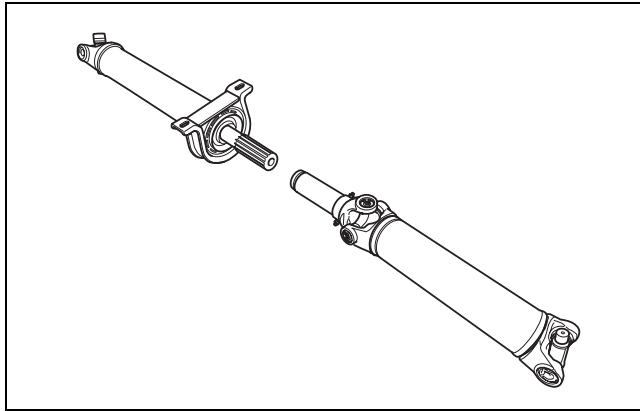

Figure 8.18

3. Remove the seal from the slip shaft. Figure 8.19.

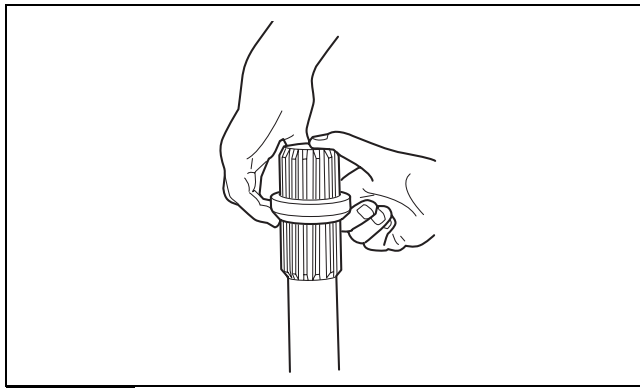

Figure 8.19

Three-Piece Standard/Outboard Slip Driveline

To disassemble the three-piece standard or outboard slip driveline, refer to the disassembly procedures for the standard slip and outboard slip configurations on the preceding pages.

Assembly

Standard Slip Configuration

1. Remove the grease fittings from the slip yoke before you assemble the slip yoke and spline shaft sections.
2. Use the grease packet supplied with the slip yoke to apply the entire amount of grease into the slip yoke. Figure 8.20.

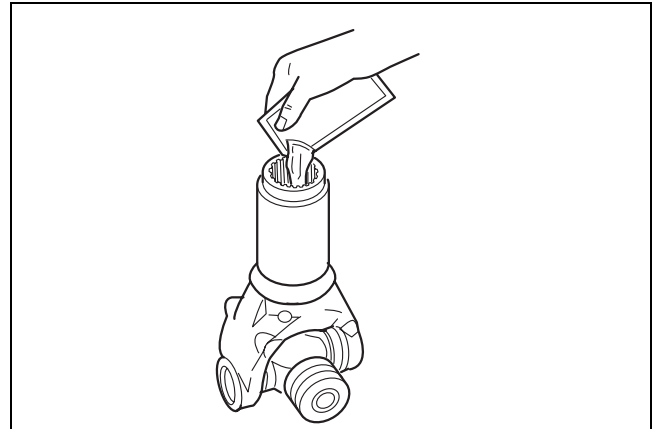

Figure 8.20

3. Use a brush to distribute lubricant on the splines. Figure 8.21.

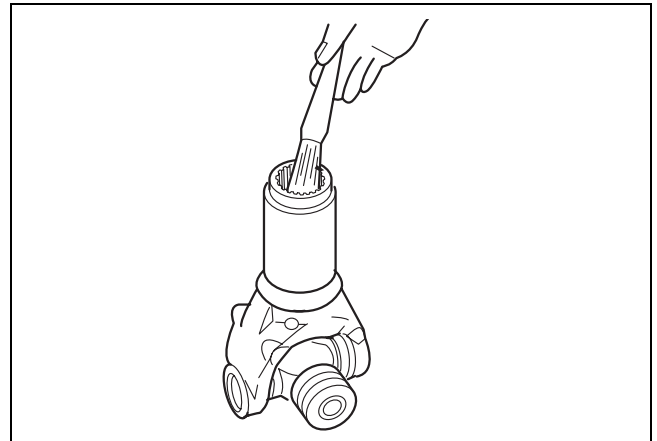

Figure 8.21

4. Install the new seal onto the spline shaft neck. Ensure that the small diameter side fits onto the splines first. Figure 8.22.

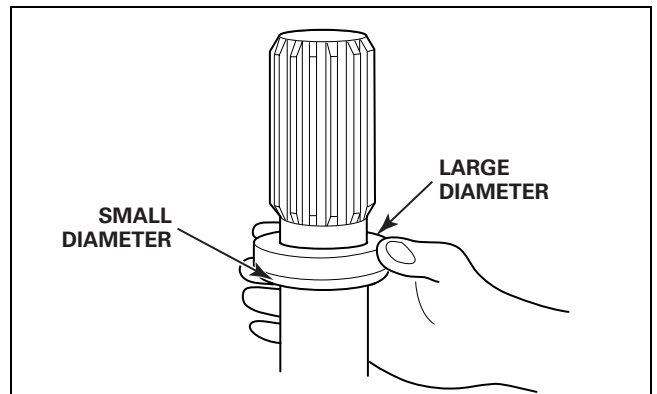

Figure 8.22

8 155R Series Slip Drive Shaft Assembly

- Align the slip yoke and spline shaft sections with the phasing marks you made on these sections during disassembly. Figure 8.23.

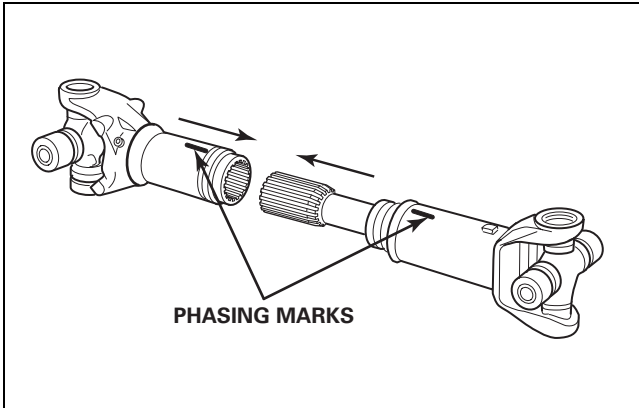

Figure 8.23

- Install the spline shaft into the slip yoke until the splines fully engage. Figure 8.23.
- Snap the seal into the groove. Figure 8.24.

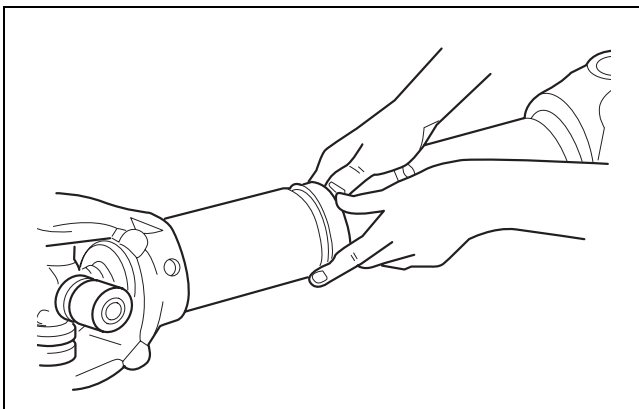

Figure 8.24

- Use a brass or copper hammer to tap the shroud over the seal. Push together the driveline sections. Figure 8.25 and Figure 8.26.

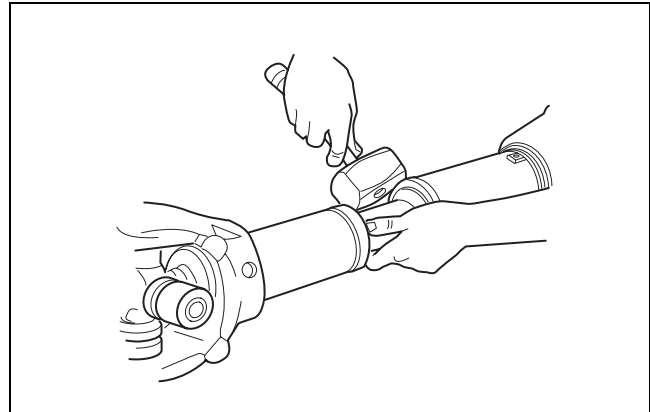

Figure 8.25

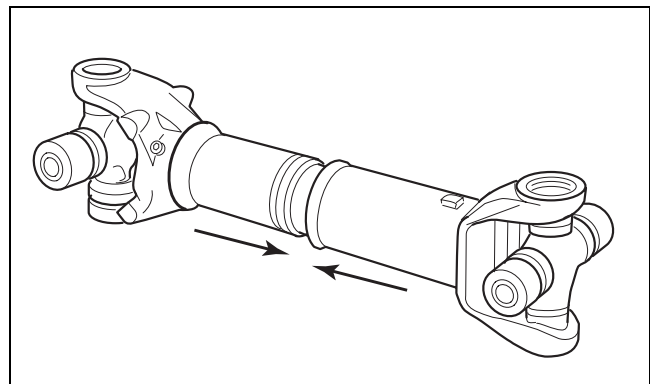

Figure 8.26

- Reinstall the grease fittings.

Installation

Universal Joint

⚠ CAUTION

Do not use grease or anti-seize compound in the yoke ear bores. Damage to components can result.

- Clean dirt and contamination from the slip yoke and weld yoke ear bores.

NOTE: The deflector is preassembled onto the bushing.

- Verify that the plastic deflectors are attached to the bushings. Figure 8.27.

8 155R Series Slip Drive Shaft Assembly

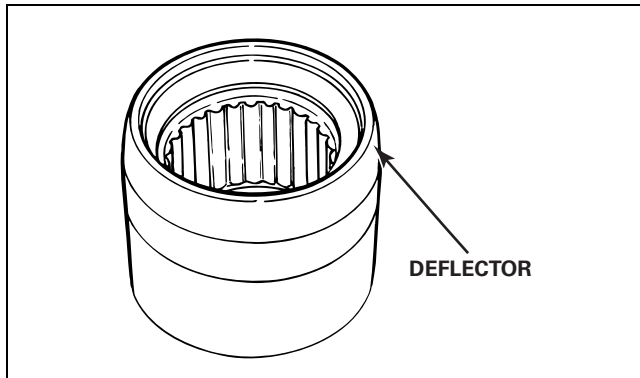

Figure 8.27

3. Position the first bushing onto the trunnion by threading the cross trunnion through the yoke bore. Figure 8.28.

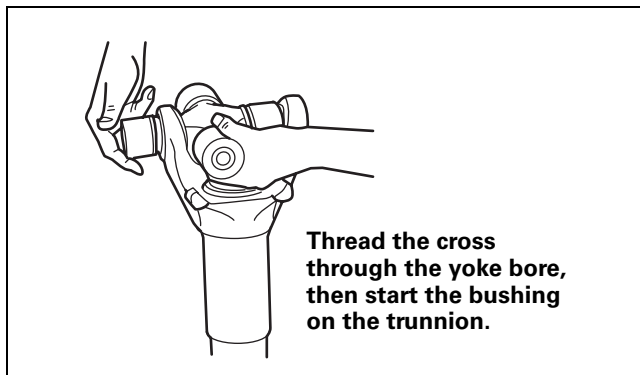

Figure 8.28

⚠ WARNING

Observe all warnings and cautions provided by the press manufacturer to avoid damage to components and serious personal injury.

⚠ CAUTION

Use an arbor press, universal joint press or yoke bearing cup installation tool to install the round bushing into the yoke. Do not use a hammer, which can loosen and damage components.

4. Use an appropriate press, yoke bearing cup installation tool or universal joint press to install the first bushing slightly past the snap ring groove. When the bearing cup installation tool contacts the yoke, it is installed correctly. Figure 8.29, Figure 8.30 and Figure 8.31.

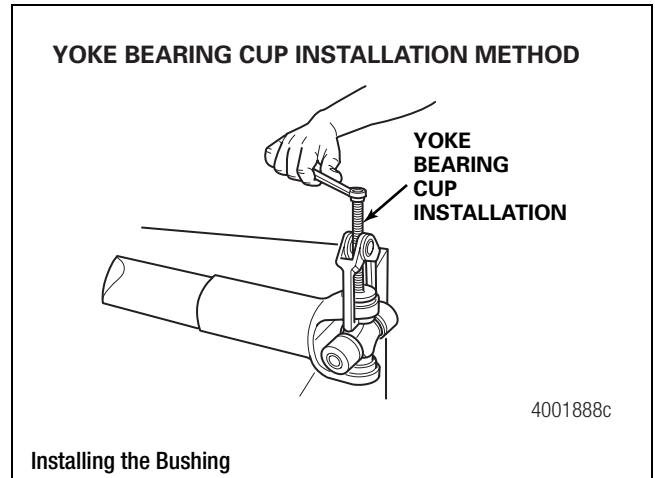

Installing the Bushing

Figure 8.29

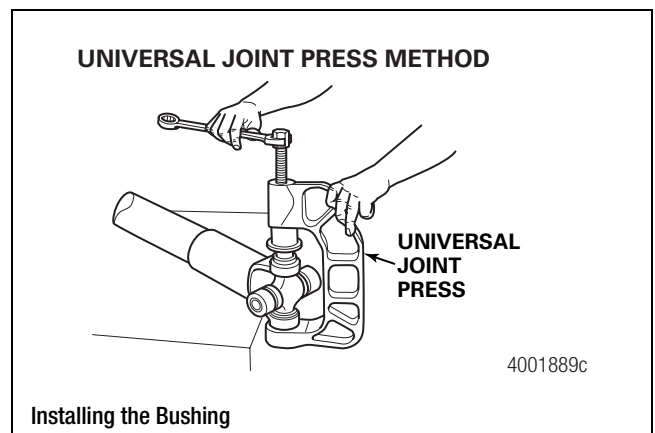

Installing the Bushing

Figure 8.30

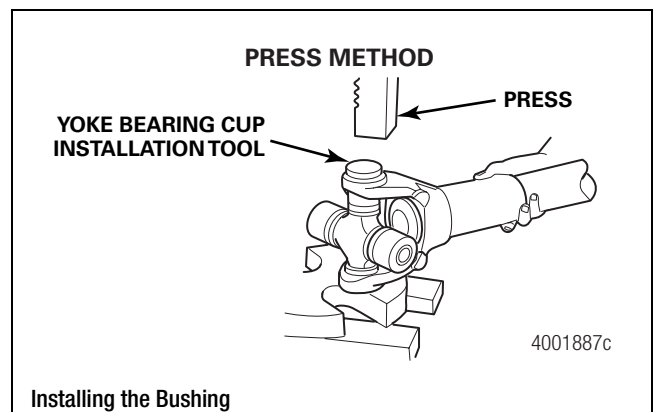

Installing the Bushing

Figure 8.31

8 155R Series Slip Drive Shaft Assembly

⚠ CAUTION

You must fully seat the snap ring into the snap ring groove to avoid damage to the driveline.

5. Use snap ring pliers to install the snap ring into the snap ring groove. Figure 8.32. Fully seat the snap ring.

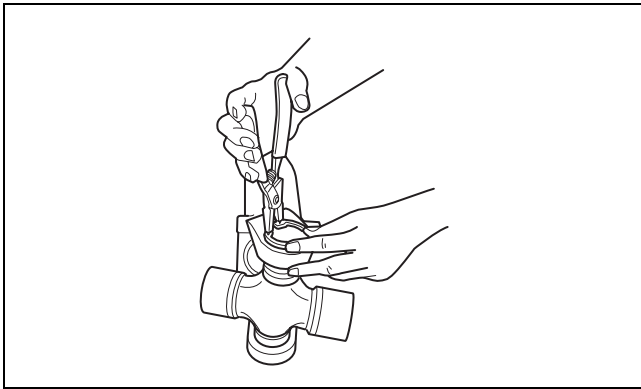

Figure 8.32

6. Position the second bushing onto the trunnion by threading the cross through the yoke bore as shown. Figure 8.33.

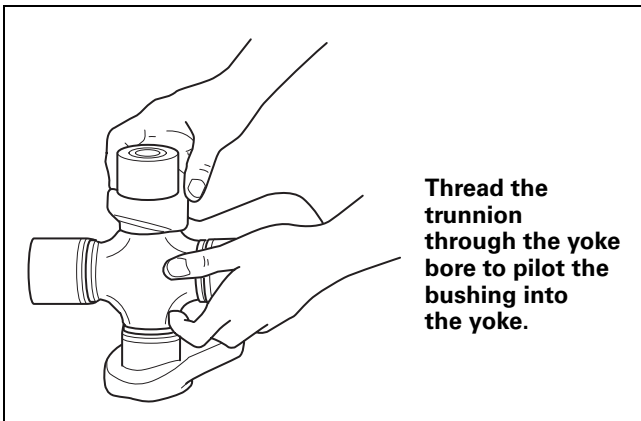

Figure 8.33

7. Use an appropriate press, yoke bearing cup installation tool or universal joint press to install the second bushing slightly past the snap ring groove. Check that the bushing is aligned with the universal joint. Figure 8.29, Figure 8.30 and Figure 8.31.

⚠ CAUTION

You must fully seat the snap ring into the snap ring groove to avoid damage to the driveline.

8. Use snap ring pliers to install the second snap ring into the snap ring groove. Figure 8.34.

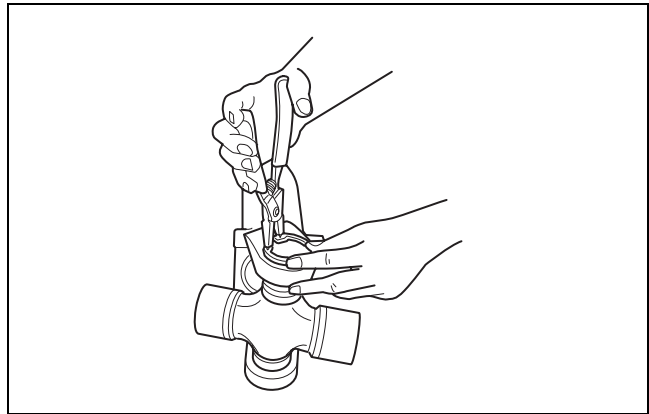

Figure 8.34

9. Strike the yoke ear with a brass or copper hammer to ensure that the universal joint moves freely. Figure 8.35.

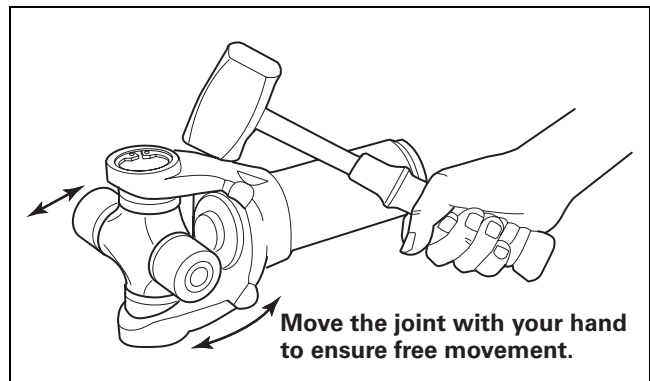



Figure 8.35

Driveline

1. Wipe off the yoke saddle.
2. Support the driveline. Install the bearing straps and capscrews onto the slip yoke end of the driveline.

8 155R Series Slip Drive Shaft Assembly

NOTE: Capscrews have a “lock patch” and can be hand-tightened only two or three threads.

3. Hand-tighten the capscrews through the bearing strap into the yoke.
4. Use a torque wrench to alternately tighten the capscrews to Meritor’s driveline torque specification. Figure 8.36. 

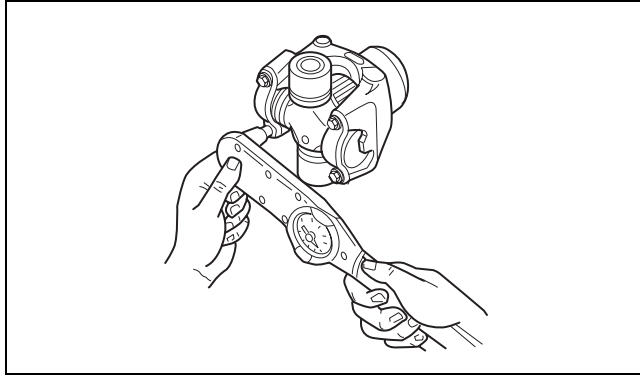

Figure 8.36

5. Repeat Step 1 to Step 3 to attach the weld yoke end of the driveline to the vehicle.

Lubrication

Universal Joint

Lubricate the universal joints at the grease fitting until grease flows from the bearing cup seals on all four trunnions. Use a grease that meets Meritor specification O-634-B, NLGI Grade 2 with EP additive. Figure 8.37.

- **If grease does not purge from all four trunnion seals:** Follow the steps below.

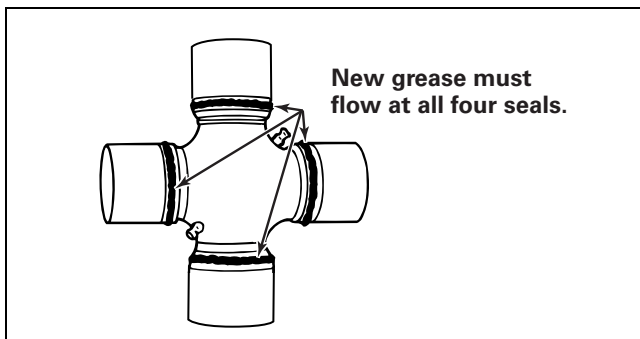

Figure 8.37

- A. Move the assembly UP-AND-DOWN or SIDE-TO-SIDE while you apply grease gun pressure.
 - B. Loosen the bearing cup capscrews. Add grease until grease purges from the four seals.
 - C. Tighten the bearing cup capscrews after grease purges.
- **If grease still does not purge from all four trunnion seals:** Remove the universal joint and correct the problem. If you cannot, replace the universal joint.

Slip Yoke Splines

Add a grease that meets Meritor specification O-634-B, NLGI Grade 2 with EP additive, to the slip yoke grease fittings. Six to eight pumps or approximately one oz (28 grams) is sufficient to lube the splines. Figure 8.38.

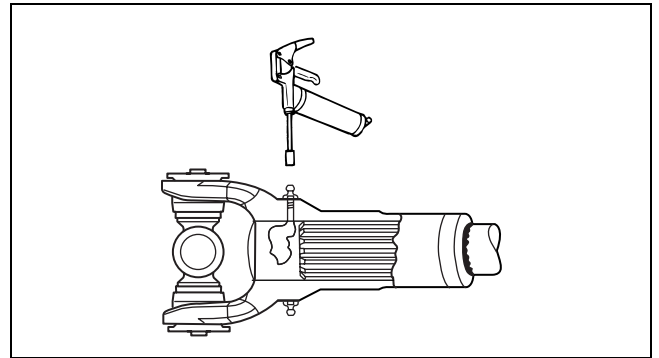

Figure 8.38

9 Center Bearing Removal and Installation

Hazard Alert Messages

Read and observe all Warning and Caution hazard alert messages in this publication. They provide information that can help prevent serious personal injury, damage to components, or both.

⚠ WARNING

To prevent serious eye injury, always wear safe eye protection when you perform vehicle maintenance or service.

Do not use a steel hammer to seat bearing cups into yoke bores. A steel hammer can cause the yoke or bearing cup to crack and break off. Serious personal injury and damage to the trunnion, yoke or bearing cup can result.

Only install the correct grade new bearing retainer bolts and stamped strap bolts. Do not reuse these parts. If the bearing retainer straps are damaged, install new retainers. Damaged and reused parts can affect driveline operation, which can cause the driveline to separate from the vehicle. Serious personal injury and damage to components can result.

A driveline assembly can weigh more than 100 pounds (46 kilograms). Always use lifting devices and the correct procedures when you handle drivelines to prevent serious personal injury and damage to components.

Overview

The Procedures in This Section Apply to All Meritor Drivelines

The center bearing removal and installation procedures in this section apply to Meritor RPL Permalube™, Wing-Style Permalube™, Easy Service™, Full-Round and 155R drivelines.

Self-Aligning Center Bearings

Some vehicles manufactured after January 18, 2002, are equipped with self-aligning center bearings. Deflectors are integral to a self-aligning center bearing, so separate deflectors are not required. You can identify a self-aligning center bearing by the bright gold color of the integral deflector. Figure 9.1.

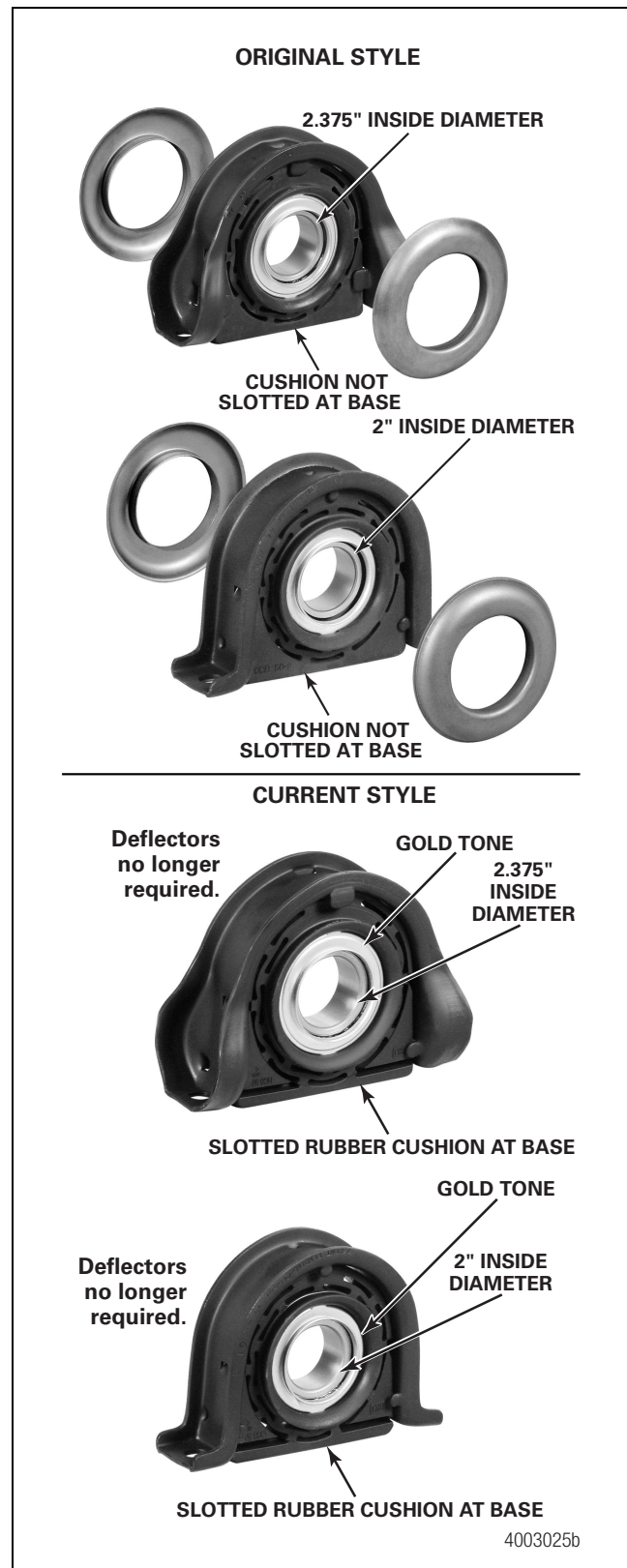

Figure 9.1

9 Center Bearing Removal and Installation

Both the original and current designs use external waterproofing grease. The external waterproofing grease is displaced by centrifugal force, which can give the impression of leakage under normal conditions. Normal leakage is shown in the next two illustrations. This condition does not require center bearing replacement. Figure 9.2 and Figure 9.3.

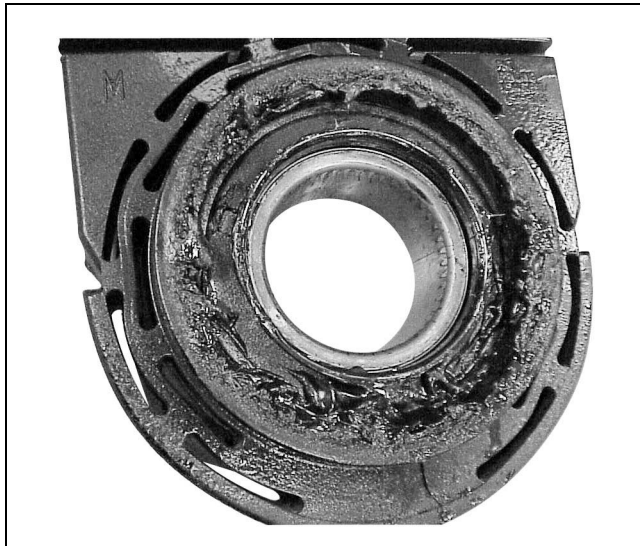

Figure 9.2



Figure 9.3

The actual bearing grease is contained within the assembly by seals. This waterproofing grease leakage was not visible on the original-design center bearing due to the deflectors.

A self-aligning center bearing accepts \pm five degrees of angular misalignment. This helps to ensure that the hanger bearing is correctly aligned to the driveline under all operating conditions. The cushion on the self-aligning center bearing is loose by design. The looseness allows the self-aligning movement.

Removal

Coupling Shaft

1. Ensure that the support strap is in the correct position to support the weight of the driveline.
2. Remove the center bearing bracket bolts. Figure 9.4.

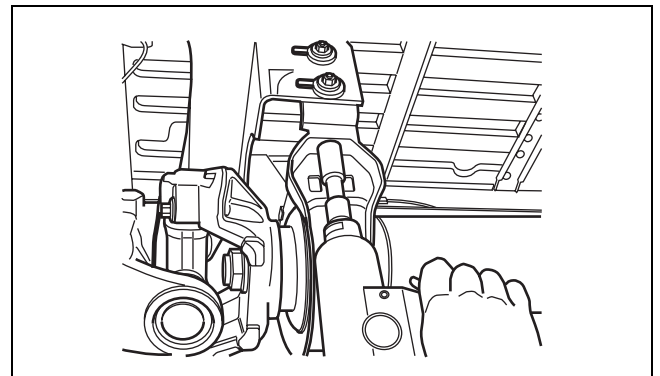

Figure 9.4

3. Remove the universal joint from the coupling yoke. Discard the universal joint mounting bolts.
 - **If it's necessary to unseat the bearing cup assemblies:** Use a rubber hammer to tap on the yoke or bearing cup. Once the coupling shaft is free, remove it from the support straps and move the driveline to a workbench.
 - **For driveline assemblies with more than two coupling shafts:** Repeat Step 1 to Step 3 as necessary. Place the support straps on the additional coupling shafts.

9 Center Bearing Removal and Installation

Disassembly

Coupling Yoke and Coupling Shaft

⚠ WARNING

Always replace a loose or damaged coupling yoke. Only install a new coupling shaft yoke nut. Do not reuse this part. A loose or damaged coupling yoke, or a reused yoke nut, can affect driveline performance and cause the driveline to separate from the vehicle. Serious personal injury and damage to components can result.

1. Remove the coupling shaft yoke nut. Discard the nut. Inspect the yoke washer. You can reuse the washer if it's not damaged. Figure 9.5.
 - **If the yoke washer is damaged:** Discard the washer and replace it with a new one.

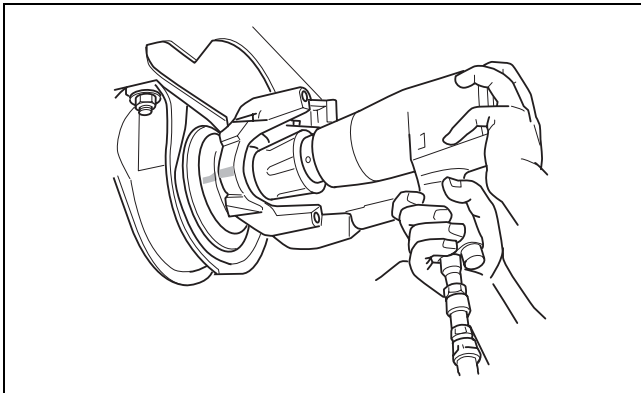

Figure 9.5

⚠ WARNING

Always reassemble a driveline according to the vehicle's original phasing type. A driveline that is not balanced correctly can affect driveline performance and cause the driveline to separate from the vehicle. Serious personal injury and damage to components can result.

2. Mark the end yoke counterbore to the coupling shaft "nose." This will help you to reassemble the center bearing end yoke in its original phased position. Figure 9.6.

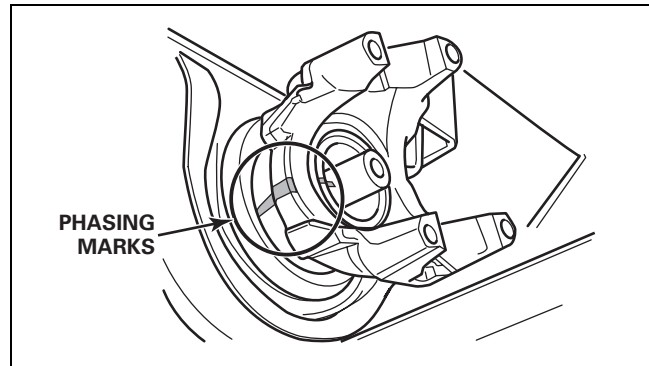

Figure 9.6

3. Remove the center bearing bracket bolts. Figure 9.7. Allow the coupling shaft to rest on the support strap.

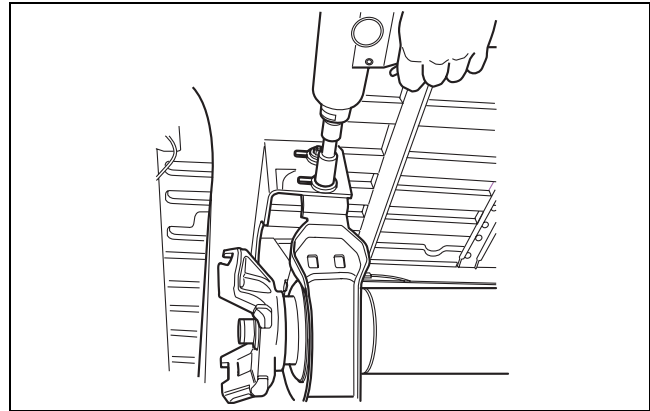

Figure 9.7

4. Remove the coupling shaft with the center bearing. Remove the coupling yoke, then the center bearing.
 - **If it's necessary to unseat the cup assemblies:** Use a rubber hammer to tap on the yoke or bearing cup. Once the coupling shaft is free, remove it from the support straps. Move the coupling shaft to a workbench area.

⚠ CAUTION

The center bearing end yoke has a press fit. Use a puller tool to remove it from the driveline. Do not use a hammer. Damage to components can result.

5. Place the driveline on a workbench. Use a puller to remove the center bearing end yoke. Do not use a hammer. Follow the puller tool manufacturer's instructions. Figure 9.8.
 - **If the yoke is loose enough to remove by hand:** Replace the entire coupling shaft.

9 Center Bearing Removal and Installation

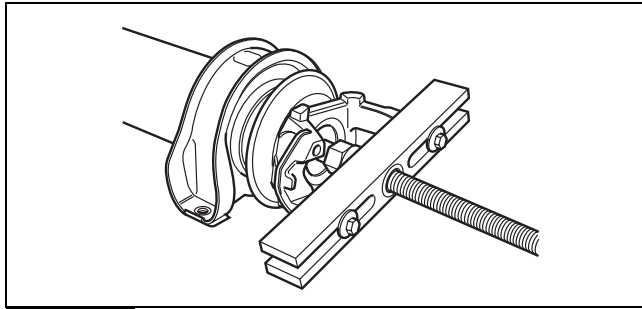

Figure 9.8

6. Inspect the center bearing end yoke splines.
 - **If the splines are damaged or missing, or the yoke is cracked:** Replace the yoke.
7. Inspect the coupling shaft splines and threads.
 - **If the splines or threads are damaged or missing:** Replace the entire coupling shaft.

Center Bearing

1. Remove and discard the center bearing bracket. Figure 9.9.

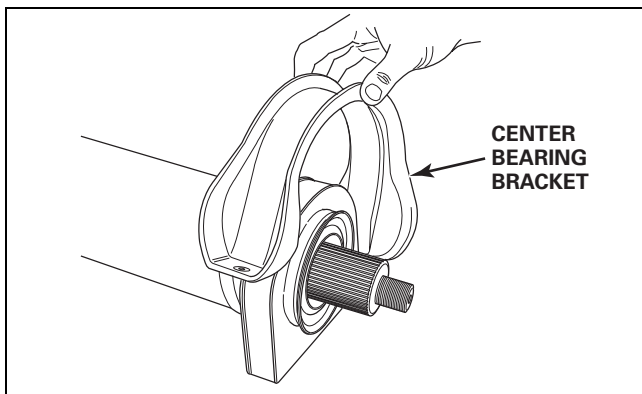

Figure 9.9

2. Remove and discard the rubber cushion. Figure 9.10.

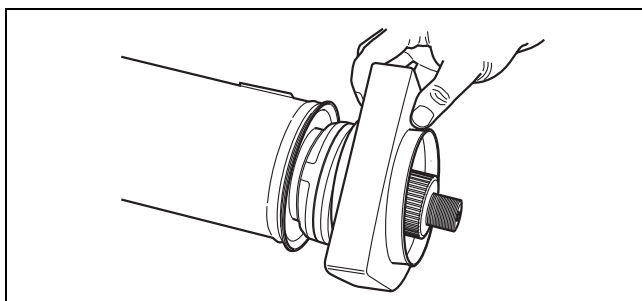

Figure 9.10

3. Use a puller to remove the bearing assembly from the coupling shaft. Follow the puller tool manufacturer's instructions. Discard the center bearing. Figure 9.11.

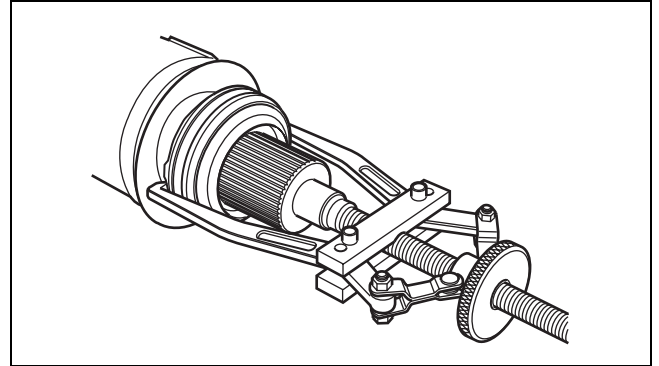

Figure 9.11

4. Inspect the coupling shaft for wear on the bearing diameter.
 - **If the coupling shaft is damaged from a seized bearing:** Replace the entire coupling shaft. Figure 9.12.

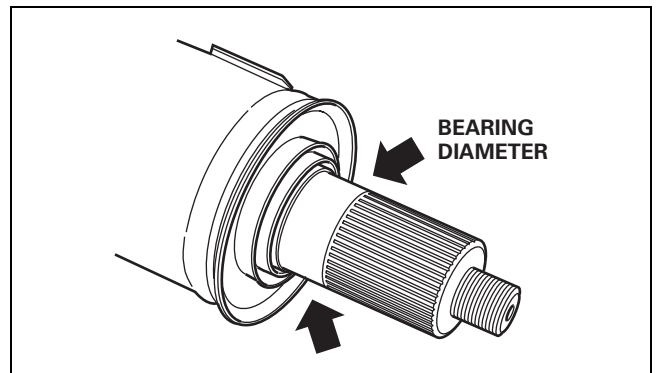

Figure 9.12

NOTE: Deflectors are integral to a self-aligning center bearing, so separate deflectors are not required.

5. Remove both deflectors, if equipped. Install a new center bearing, deflectors, if necessary, and coupling yoke.

9 Center Bearing Removal and Installation

Installation

Deflectors

1. Wipe the center bearing support surface with a fine emery cloth.

NOTE: Deflectors are integral to a self-aligning center bearing, so separate deflectors are not required.

2. If necessary, install a new deflector on the coupling shaft. To avoid damaging the deflector, use a section of tubing and a brass hammer to seat the deflector. Verify that the deflector is completely seated against the center bearing support shoulder. Figure 9.13.

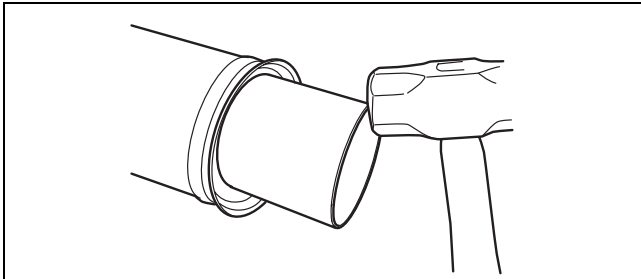

Figure 9.13

Center Bearing

NOTE: Deflectors are integral to a self-aligning center bearing, so separate deflectors are not required.

1. Install deflectors, if included in the center bearing kit. Otherwise, deflectors are not required.
2. Carefully align the new center bearing assembly with the machined surface of the coupling shaft. Use your hands to push the center bearing onto the coupling shaft. Figure 9.14.

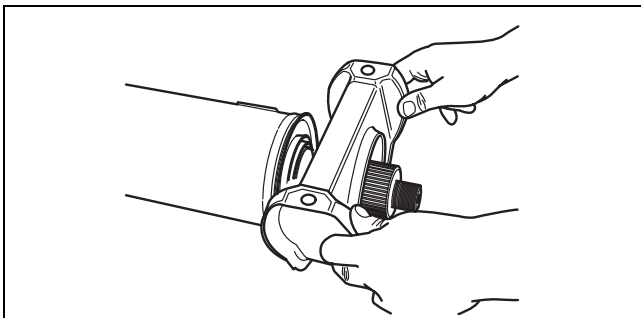

Figure 9.14

3. Use a punch and brass hammer to install the bearing.
4. If a deflector is required, use a section of tubing and a brass hammer to press the deflector remaining onto the end yoke to avoid damaging the deflector. Figure 9.15.

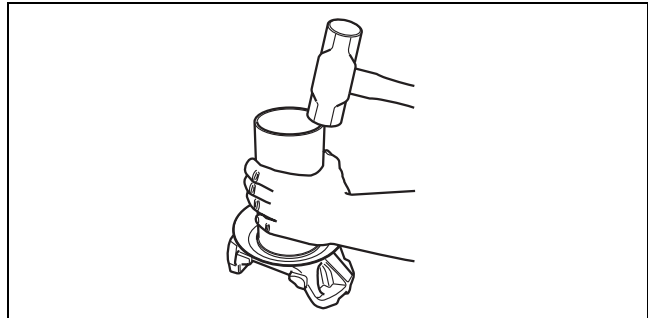



Figure 9.15

5. Use a rubber hammer to tap the yoke onto the coupling shaft splines. The phasing marks on the driveline must be aligned. Figure 9.6. Continue to tap the yoke until it is completely seated against the center bearing. Do not use the nut to draw the yoke down.
6. Install a washer and a new coupling shaft yoke nut. Tighten the nut to 450-600 lb-ft (612-816 N•m). 

Coupling Shaft

1. Verify that the support straps are in the correct position to support the weight of the driveline.
2. Align the center bearing bracket with the frame support.
3. Install bearing spacers, if necessary, to return the bearing bracket to its original position. Figure 9.16.

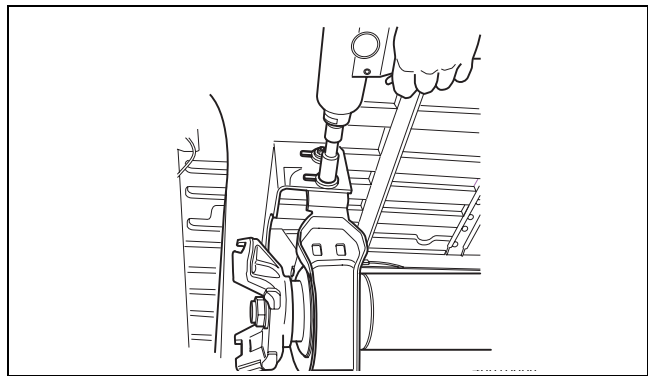

Figure 9.16

4. Install the center bearing bracket bolts. Tighten them to the vehicle manufacturer's specification.

10 Lubrication

Hazard Alert Messages

Read and observe all Warning and Caution hazard alert messages in this publication. They provide information that can help prevent serious personal injury, damage to components, or both.

⚠ WARNING

To prevent serious eye injury, always wear safe eye protection when you perform vehicle maintenance or service.

Maintenance

Greaseable Drivelines

The Full-Round, Easy Service™, Wing-Style and 155R greaseable drivelines require periodic lubrication of the universal joints and slip yoke splines. Figure 10.1 and Figure 10.2.

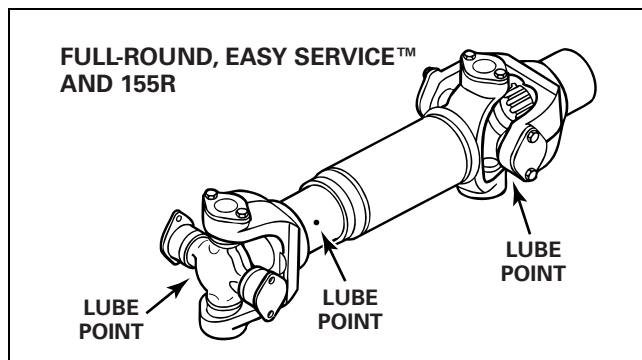

Figure 10.1

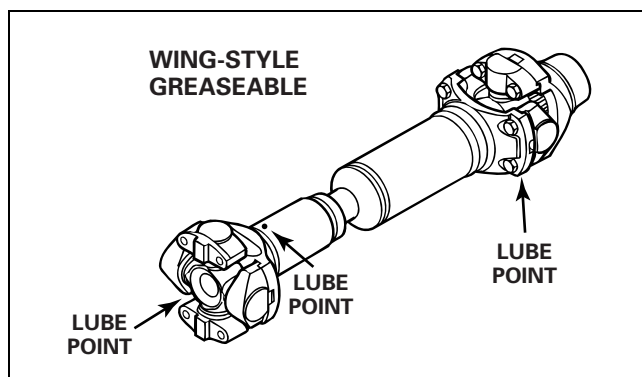

Figure 10.2

Non-Greaseable Drivelines

The RPL Series Permalube™ non-greaseable driveline is completely lubricated and sealed at the factory and does not require lubrication. Figure 10.3.

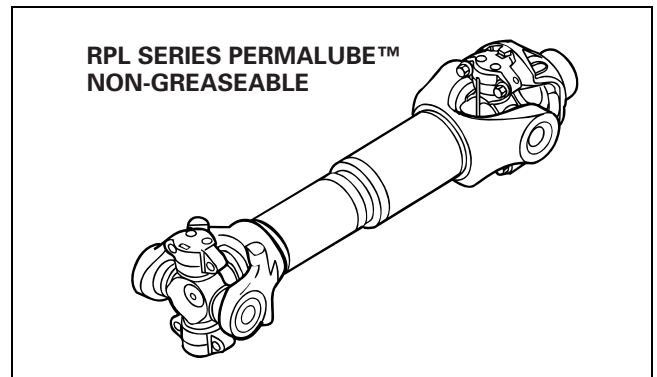

Figure 10.3

The Wing-Style Permalube™ non-greaseable driveline requires lubrication of the slip yoke splines ONLY. Figure 10.4.

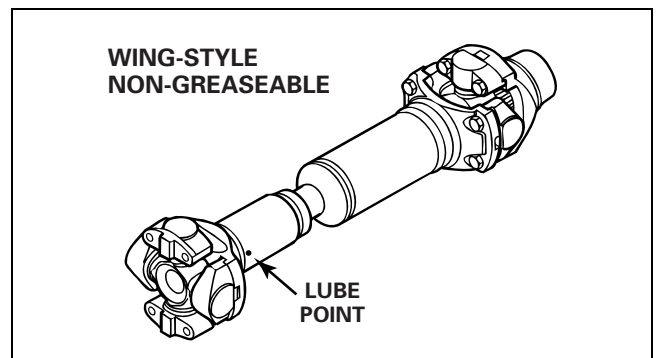

Figure 10.4

Inspection

Driveline

1. Inspect the Full-Round, Easy Service™, Wing-Style and 155R greaseable drivelines for wear and damage at regularly scheduled maintenance intervals specified in Table E.
2. Inspect RPL Series Permalube™ and Wing-Style Permalube™ non-greaseable drivelines at least every 25,000 miles (40 000 km).

10 Lubrication

Table E: Lubrication Intervals for Full-Round, Easy Service™, Wing-Style and 155R Greaseable Drivelines

Component	Application	Greasing Interval	Grease	Meritor Specification	NLGI Grade	Grease Description	Outside Temperature
Universal Joint, Slip Yoke and Splines	Line Haul — Applications where tractor is operated entirely on concrete or smooth paved road surfaces	50,000 miles (80 000 km)	Universal Joint Grease	O-634-B	2	Lithium 12-Hydroxy Stearate with Molybdenum Disulfide	Refer to the grease manufacturer's specifications for the temperature service limits.
	On Highway — Applications where tractor is operated at least 90% on paved road surfaces and up to 10% on gravel, dirt or unpaved roads	16,000 miles (25 000 km)					
	City — Applications where truck is operated at least 90% in city environment	6,500 miles (10 000 km)					
	Construction — Straight trucks used in the construction industry to move materials to and from job sites. They operate 90% on-road and 10% off-road with a high number of stops and starts	The greasing interval depends on the individual operating conditions, speed and loads. To determine the interval, inspect for the presence of grease at all positions until an interval can be determined. Grease the assembly as necessary.					

Table F: Approved Lubricants

Lubricant	Recommendation
Universal Joint Grease	Must meet Meritor Specification O-634-B (NLGI Grade 2, Lithium 12-Hydroxy Stearate with Molybdenum Disulfide) Amalie All Purpose Grease with Moly-L1-2M Exxon 5160 Shell Super Duty Special FF Marathon Maralube Molycode 529 Phillips Petroleum Philube MW-EP2 Grease Shell Moly Poly Grease Kendall L424 Grease Amoco Super Chassis Grease Ford Specification M1C-75B or part number PN-C1AZ 19590

11 Fastener and Torque Information

Torque Specifications

Driveline

Table G: Torque Specifications

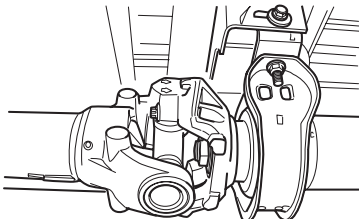
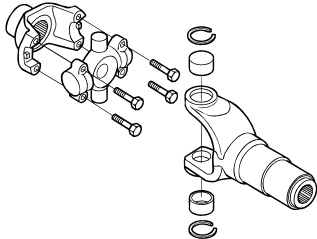
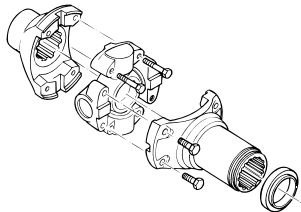
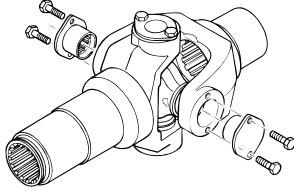
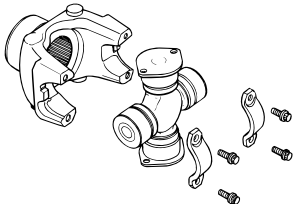
Description	Thread Size Inches	Torque Range lb-ft (N•m)
Coupling Shaft Yoke Retaining Nut 	1-1/4-18	700-750 (949-1016)
RPL Series Permalube™ Capscrews 	1/2-20	115-135 (155-183)
Wing-Style Permalube™ Capscrews 	1/2-20	115-135 (155-183)
	3/8-24	40-55 (54-74)
	7/16-20	63-83 (85-112)
Full-Round Capscrews 	5/16-24	26-35 (35-47)
	3/8-24	38-48 (51-65)
Easy Service™ Capscrews 	3/8-24 ¹	40-55 (54-75)
	3/8-24 ²	45-60 (61-81)
	1/2-20 ³	115-135 (155-183)

¹ 155R Driveline Series

² 16T Driveline Series

³ 17T, 17LT, 18T Driveline Series

12 Troubleshooting

Hazard Alert Messages

Read and observe all Warning and Caution hazard alert messages in this publication. They provide information that can help prevent serious personal injury, damage to components, or both.

WARNING

To prevent serious eye injury, always wear safe eye protection when you perform vehicle maintenance or service.

Special Tools

NOTE: The EVA 2 vibration analyzer can be used to determine the source of a vibration. Refer to the Service Notes page on the front inside cover of this manual for information on how to obtain SPX Kent-Moore tools.

Troubleshooting

Table H: Vibration

Condition	Cause	Correction
Driveline vibration	Driveline phasing incorrect	Correct the phasing by aligning the yokes on both ends of the driveline.
	Missing balance weights or foreign material on driveline tubing	Have the driveline balanced.
	Transmission or axle end yokes loose	Inspect for radial looseness. Tighten the nut or replace the end yoke.
	Excessive end play in universal joints	Replace the universal joints.
	Excessive hinging in slip section	Replace worn components.
	Welch plug loose or missing in slip yoke	Replace the welch plug or slip yoke.
	Worn center bearing	Replace the center bearing.
	Chassis ride height too low or too high	Readjust the ride height.
	Torsional accelerations in driveline	Measure the transmission, driveline and axle planes. Record the readings and run the Driveline Analysis Program. If the angles are found to be out of specifications, adjust or replace components as directed.
	Loose, missing or damaged driveline fasteners or parts	Tighten loose fasteners, and replace damaged and missing parts.
Low gear shudder at full drive or full coast under light load conditions	Incorrect phasing	Reassemble with correct phasing.
	Driveline weight incompatible with engine-transmission mounting	Install a two-piece driveline with a shaft support bearing.
	Driveline too long for speed	Install a two-piece driveline with a shaft support bearing.
	Loose outside diameter fit on slip yoke spline	Change the slip yoke and spline plug.
	Universal joint loose	Inspect the universal joint for looseness; tighten to specification. Replace if necessary.
	Driveline out of balance or bent	Rebalance or replace.
	Worn universal joint	Replace the universal joint.
	Torsional or inertial excitation	Reduce the universal joint continuous running angle by adding shims to driveline components.

12 Troubleshooting

Table I: Premature Wear

Condition	Cause	Correction
Low mileage universal joint wear	End yoke cross hole misalignment	Use an alignment bar to check for end yoke cross hole misalignment. Replace the end yoke if misaligned.
	Excess angularity	Check the universal joint operating angles. Reduce the angles if necessary.
	Incorrect or inadequate lubrication	Lubricate according to specifications (non-RPL designs).
	Worn or damaged seals	Replace the universal joint kit.
Repeat universal joint wear	Excessive continuous running load	Replace with a higher capacity universal joint and driveline.
	Continuous operation at high angle/high speed	Replace with a higher capacity universal joint and driveline. Check the universal joint operating angles. Reduce the angles if necessary.
	Worn or damaged seals	Replace the universal joint kit.
	Incorrect or inadequate lubrication	Lubricate according to specifications (non-RPL designs).
End galling of cross trunnion and bearing assembly	Excessive angularity	Check the universal joint operating angles. Reduce the angles if necessary.
	Excessive torque load for universal joint and driveline size	Replace with a higher capacity universal joint and driveline.
	Incorrect or inadequate lubrication	Lubricate according to specifications (non-RPL designs).
	Excessive continuous running load	Replace with a higher capacity universal joint and driveline.
Needle rollers brinelled into bearing cup and cross trunnion	Continuous operation at high angle/high speed	Replace with a higher capacity universal joint and driveline. Check the universal joint operating angles. Reduce the angles if necessary.
	Insufficient operating angles	Increase the operating angles to a minimum of two degrees.
	Normal bearing wear	Replace worn components. If brinelling is in a small area, it is not necessary to replace components
	Incorrect or inadequate lubrication	Lubricate according to specifications (non-RPL designs).
Spalling of needles into trunnion	Incorrect or inadequate lubrication	Lubricate according to specifications (non-RPL designs).
	Dirt contamination	Replace worn components. If brinelling is in a small area, it is not necessary to replace components
	Normal bearing wear	Replace worn components.
	Excessive torque load for universal joint and driveline size	Replace with a higher capacity universal joint and driveline.
Broken cross and bearing assemblies	Excessive torque load for universal joint and driveline size	Replace with a higher capacity universal joint and driveline.

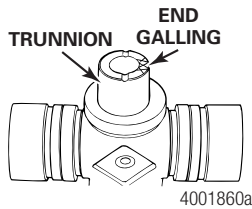

Needle rollers brinelled into bearing cup and cross trunnion

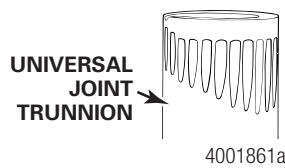

Spalling of needles into trunnion

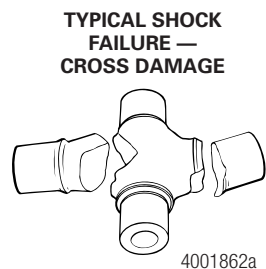

12 Troubleshooting

Table J: Slip Yoke Spline Wear

Condition	Cause	Correction
Seizure	Incorrect lubrication	Lubricate the slip yoke spline according to specifications. Check the seal.
	Worn or damaged part	Replace the spline components.
	Contamination	Lubricate the slip yoke spline according to specifications. Check the seal.
Galling	Worn or damaged parts	Replace the spline components.
	Contamination	Lubricate the slip yoke spline according to specifications. Check the seal.
Outside diameter wear at extremities	Incorrect lubrication	Lubricate the slip yoke spline according to specifications. Check the seal.
	Excessive loose outside diameter fit	Replace the spline components.
Spline shaft or tube broken in torsion	Tube size inadequate	Use a larger diameter tube.
	Excessive torque load for universal joints and driveline size	Replace with a higher capacity universal joint and driveline.

Table K: Shaft and Tube

Condition	Cause	Correction
Shaft support bearing wear	Driveline too long for operating speeds	Install a two-piece driveline with a shaft support bearing.
	Incorrect lubrication of bearings	Replace the center bearing.
Shaft support rubber insulator wear	Bending fatigue due to secondary couple loads	Reduce the universal joint continuous running angle.
	Excessive torque load for universal joint and driveline size	Replace with a higher capacity universal joint and driveline.
	Shaft support bearing misaligned; interferes with deflector	Realign the mounting bracket-to-frame crossmember to eliminate interference with the deflector.
Tube circle weld fracture	Balance weight located in apex of weld yoke lug area	Replace the tubing and rebalance.
	Balance weight too close to circle weld	Replace the tubing and rebalance.
	Incorrect circle weld	Replace the tubing and rebalance.
Shaft broken in bending	Driveline too long for operating speeds	Install a two-piece driveline with a shaft support bearing.
	Bending fatigue due to secondary couple loads	Reduce the universal joint continuous running angle.

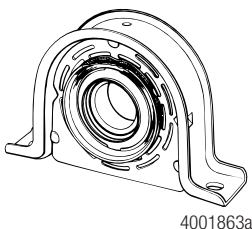

12 Troubleshooting

Table L: Yoke Fracture

Condition	Cause	Correction
Yoke broken or cracked	Mating yoke lug interference at full jounce and rebound	Replace the yoke. Check the design for application. Use high angle yokes.
 4001864a	Excessive torque load for universal joint and driveline size	Replace with a higher capacity universal joint and driveline.
	Bending fatigue due to secondary couple loads	Reduce the universal joint continuous running angles.

Table M: Universal Joint Center Parts

Condition	Cause	Correction
Cross or trunion fracture	Abnormally high loading	Check for abuse of vehicle, stuck or overloading
Bushing fracture	Excessive load for universal joint	Check for maximum driveline torque in lowest gear. If necessary, replace with a higher capacity universal joint and driveline.
	Excessive angularity	Check the universal joint operating angles. Reduce the angles if necessary.
	Worn or damaged parts	Replace with new parts.

Table N: Yokes — Wing-Style Bushings

Condition	Cause	Correction
Loose bolts	Dirt or foreign material, such as paint, on mounting pad	Check for fretting on the mounting pads or drive tang. Surfaces must be free of foreign material and the bushings must be fully seated before bolts are fully tightened.
Broken bolts	Over or under torqued bolts	Surfaces must be free of foreign material and the bushings must be fully seated before bolts are fully tightened.
	<ul style="list-style-type: none"> If there is no fretting on the mounting pad or bolt hole and there is fretting on the drive tang: The bolt broke. If there is fretting on the mounting pad or bolt hole: The bolt was loose. 	
	Excessive angularity	Check the universal joint operating angles. Reduce the angles if necessary.

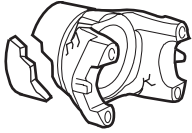
Table O: Yokes — Round Bushings

Condition	Cause	Correction
Extremely hard to remove or replace bushing	Distorted bushing hole in yoke or normally close clearances, fretting corrosion and rust build-up	When you remove a bushing, use a penetrating oil and be careful not to distort the ears on the yoke when you hammer on the center cross. Remove grease, rust and dirt from the mounting surfaces before assembly. Apply NeverSeez to make disassembly easier.
New center parts will not flex when you install them into the yoke	Yoke ears are distorted, causing the center parts to bind	Replace the yoke.

13 Measuring and Recording Driveline Angles

Special Tools

Tools You'll Need

- An inclinometer or a spirit level protractor to measure driveline angles. Figure 13.1 and Figure 13.2.

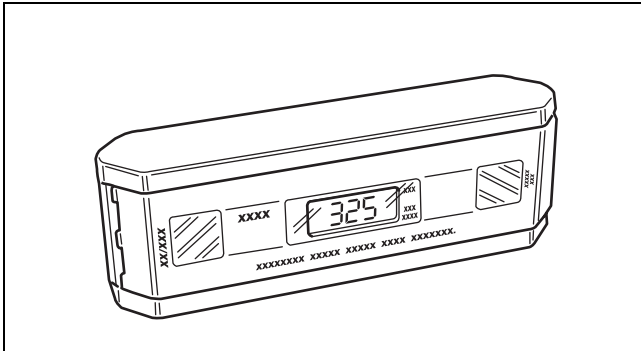

Figure 13.1

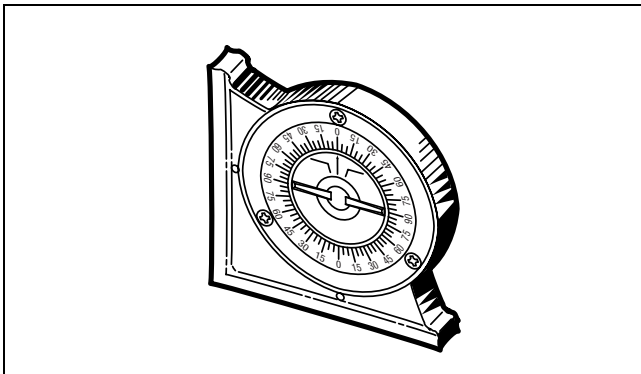

Figure 13.2

- A tape measure to measure ride height for air-ride-equipped tractors
- A Data Gathering Worksheet. Photocopy one of the several Data Gathering Worksheets provided at the end of this manual. You will use this photocopy to record the tractor's specifications and driveline angle measurements. Refer to the Service Notes page on the front inside cover of this manual for information on how to obtain additional Data Gathering Worksheets.

Overview

Prepare the Vehicle

⚠ WARNING

To prevent serious eye injury, always wear safe eye protection when you perform vehicle maintenance or service.

Park the vehicle on a level surface. Block the wheels to prevent the vehicle from moving. Support the vehicle with safety stands. Do not work under a vehicle supported only by jacks. Jacks can slip and fall over. Serious personal injury and damage to components can result.

1. Park the vehicle on a level surface. Do not engage the tractor brakes or the parking brakes.
2. Verify that all tires are on a level surface and inflated to the specified pressure.
3. Block the front tires at both the front and rear.

For Air-Ride-Equipped Tractors

1. Build air pressure to at least 115 psi (792.35 kPa).
2. Deflate air from the air bags: Use the dash-mounted deflate switch or release air pressure through the air valve at the rear of the tractor.
3. Allow the air bags to inflate completely.
4. Measure ride height with a tape measure. If necessary, adjust ride height to the correct vehicle manufacturer's specifications.

13 Measuring and Recording Driveline Angles

Data Gathering Worksheet

General Information Section

NOTE: Worksheets can be located at the end of this manual.

There are individual data gathering sheets for each of the following driveline configurations:

- One-piece driveline, single rear axle
- One-piece driveline, tandem rear axle
- Two-piece driveline, single rear axle
- Two-piece driveline, tandem rear axle

Select the correct worksheet for the vehicle's driveline configuration.

Fill in the general information section at the top right-hand corner of the data gathering worksheet. Figure 13.3.

Customer Name: Robert Smith		
Phone: (555) 555-1234	Fax: (555) 555-6789	
OEM: XXXXX	Model: XXXXXX	
VIN: (Last 6 digits only) XXXXXX	Unit: XXXXX	Year: 99
Date: 1/1/99	DSM: XXXXXX	

Phasing Type (Refer to the reverse side.)	<input type="text"/>	Transmission Angle	<input type="text"/>	1st Driveline Angle	<input type="text"/>	2nd Driveline Angle	<input type="text"/>
Maximum Engine RPM	2200						
Transmission Top Gear Ratio	0.86:1						
Rear Suspension Ride Height	37"						
Maximum Engine HP	<input type="text"/>						

Usually found on the engine specification label attached to the tractor's engine block.

If equipped with air ride.

Usually found on the transmission specification plaque attached to the tractor instrument panel.

Figure 13.3

13 Measuring and Recording Driveline Angles

Phasing Type Box

NOTE: The phasing type is not required for angle analysis of one-piece driveline configurations.

Fill in the "Phasing Type" box on the data gathering worksheet.

Refer to **Phasing Type 1, 2, 3 and 4** examples listed on the worksheet. Figure 13.4.

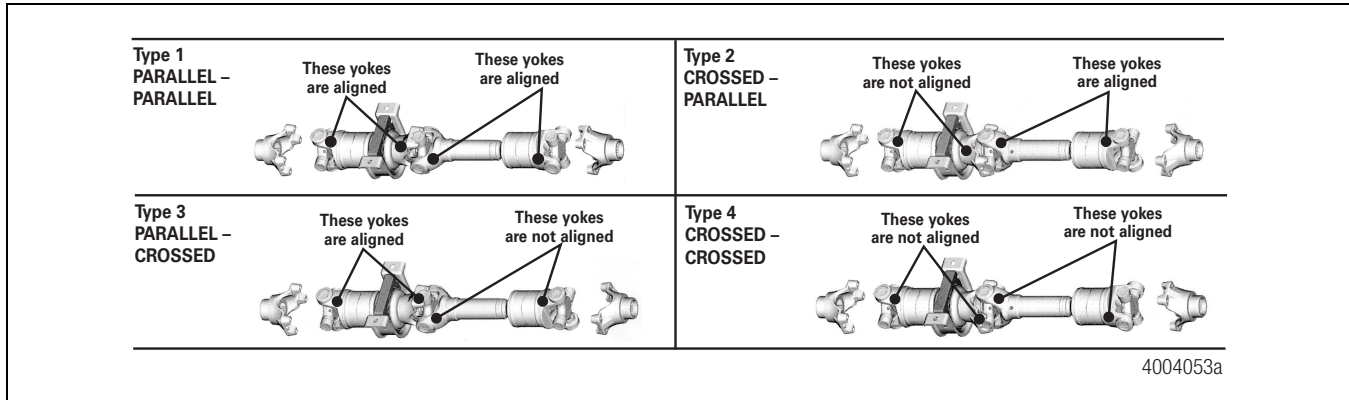

Figure 13.4

If you are unsure of the vehicle's phasing type, use "1" in the box. Figure 13.5.

Phasing Type (Refer to the reverse side.)	<input type="text" value="1"/>	
Maximum Engine RPM	<input type="text"/>	
Transmission Top Gear Ratio	<input type="text"/>	
Rear Suspension Ride Height	<input type="text"/>	
Maximum Engine HP	<input type="text"/>	
Clutch	<input type="text"/>	

Figure 13.5

13 Measuring and Recording Driveline Angles

Positive (+) and Negative (-) Angle Designations

You must fill in driveline angle measurements on the Data Gathering Worksheet as POSITIVE (+) and NEGATIVE (-) dimensions.

Before you measure a component, go to the side of the vehicle and look at the driveline. If the FRONT of the component is HIGHER than the REAR of the component, the dimension will be POSITIVE (+).

If the FRONT of the component is LOWER than the REAR of the component, the dimension will be NEGATIVE (-). Figure 13.6.

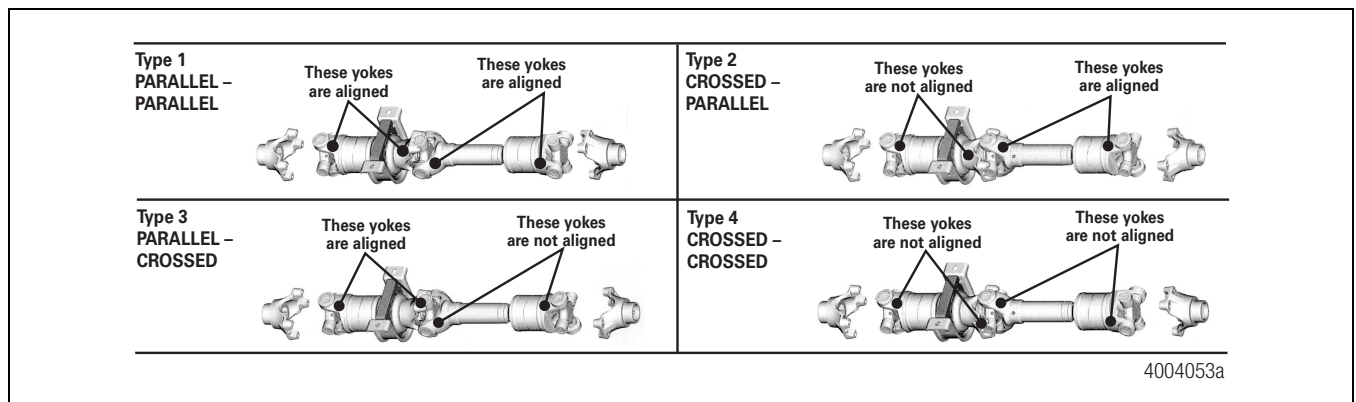

Figure 13.6

Measure

Main Driveline Angles

Measure the Transmission Output Yoke Angle

Place the inclinometer or spirit level protractor on a spacer and on the transmission output yoke to measure the transmission output yoke angle. If a measurement is difficult to obtain on the yoke, you can measure from a flat transmission surface, including the countershaft bearing covers or the PTO cover. Figure 13.7 and Figure 13.8.

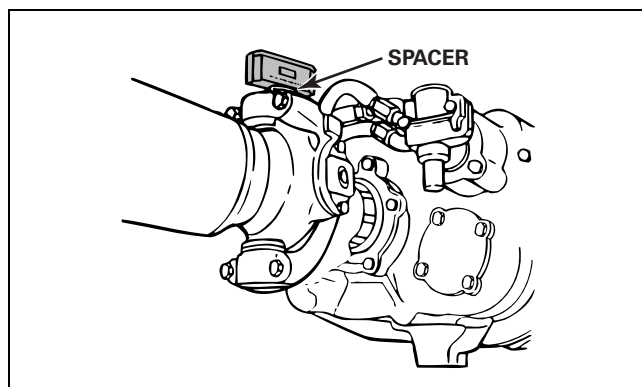

Figure 13.7

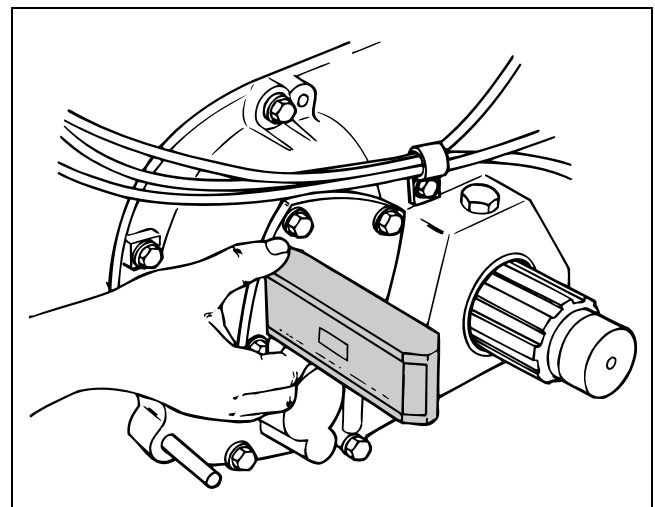

Figure 13.8

13 Measuring and Recording Driveline Angles

Record the measurement in the **Transmission Angle** box on the Data Gathering Worksheet. Figure 13.9.

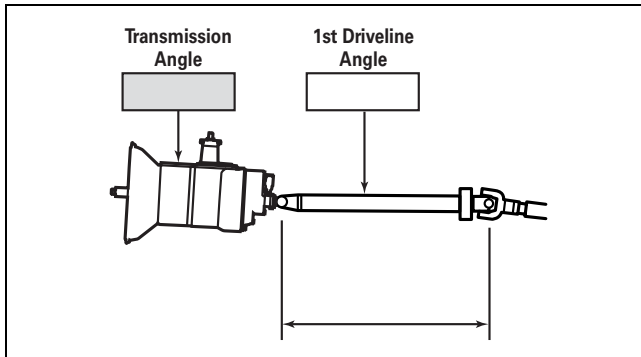

Figure 13.9

Measure the First and Second Driveline Angles

Place the inclinometer or spirit level protractor on a smooth, flat portion of the driveline tubing to measure the first and second driveline angles. Figure 13.10. **Do not measure over welds or balance weights. The measurements will not be valid.**

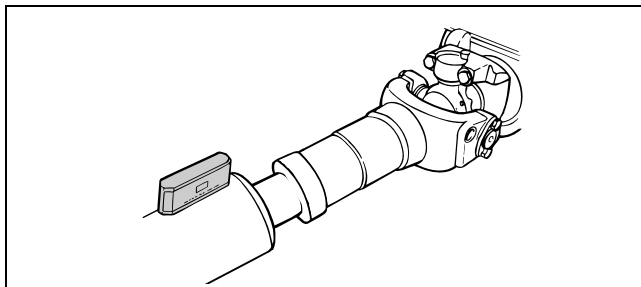

Figure 13.10

Record the measurements in the **First Driveline Angle** and **Second Driveline Angle** boxes on the Data Gathering Worksheet. Figure 13.11.

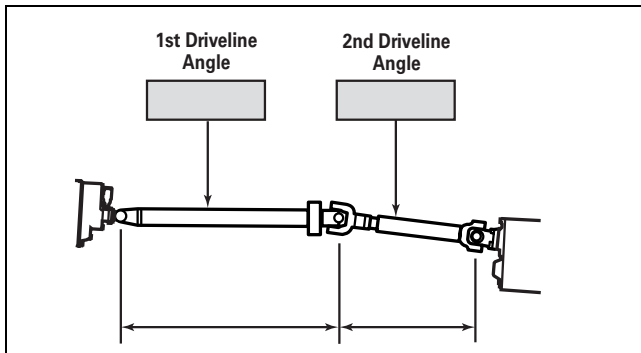

Figure 13.11

Measure the Forward Rear Drive Axle Angle

Place the inclinometer or spirit level protractor on a spacer and on the output yoke or on a smooth, flat portion of the axle housing tube (the "long" side, away from the bowl and near the suspension U-bolt) to measure the forward rear drive axle angle. Figure 13.12 and Figure 13.13.

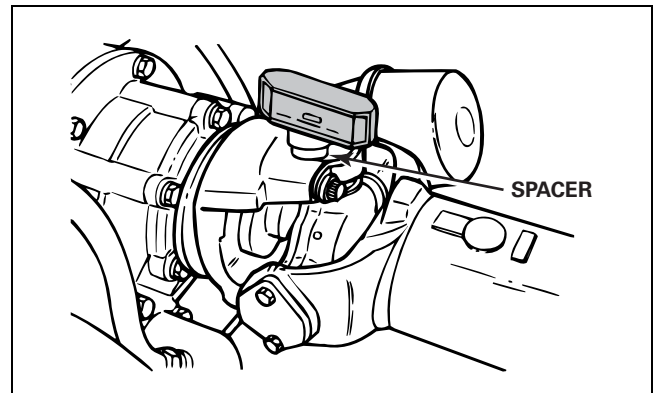

Figure 13.12

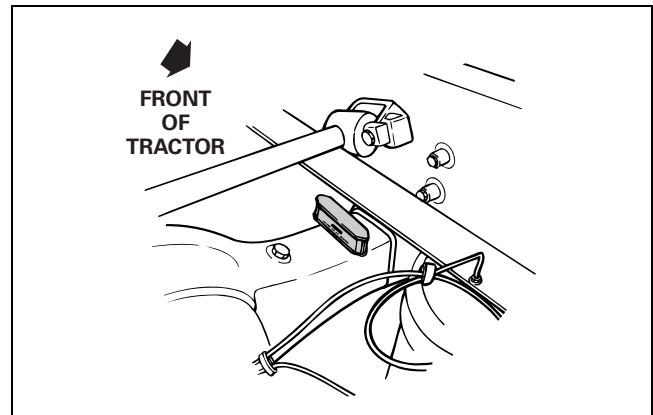

Figure 13.13

NOTE: Figure 13.13 is the preferred measurement method.

13 Measuring and Recording Driveline Angles

Write the measurement in the **Front Axle Angle** box on the Data Gathering Worksheet. Figure 13.14.

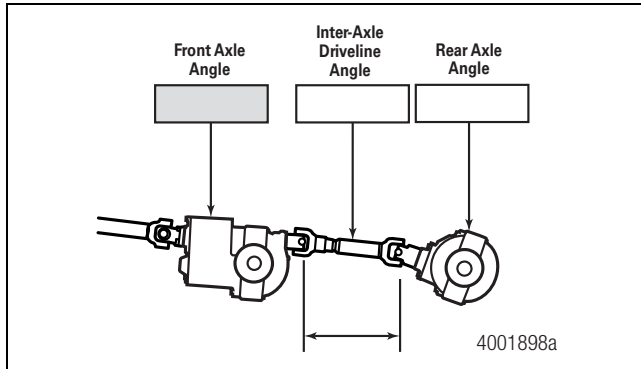

Figure 13.14

Measure the Inter-Axle Angle

Place the inclinometer or spirit level protractor on a smooth, flat portion of the driveline tubing to measure the inter-axle angle. Figure 13.15. **Do not measure over welds or balance weights. The measurement will not be valid.**

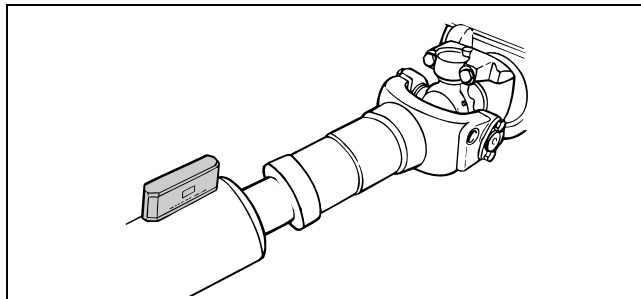

Figure 13.15

If the driveline tubing is too short, place the edge of the inclinometer or spirit level protractor vertically on the tube. Subtract 90 degrees from the reading to determine the correct angle. Figure 13.16.

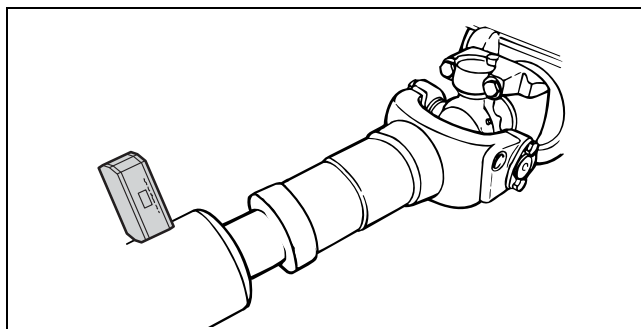

Figure 13.16

Write your measurement in the Inter-Axle Angle box on the Data Gathering Worksheet. Figure 13.17.

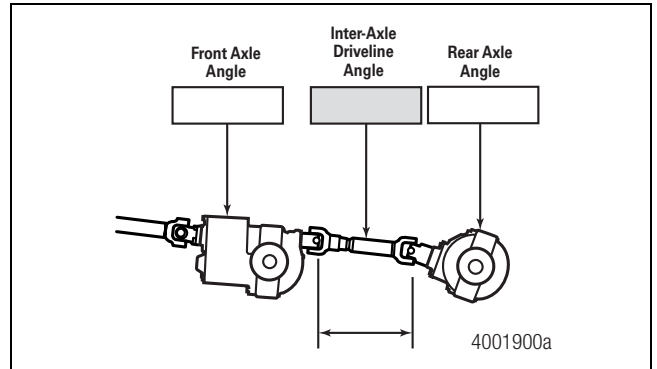

Figure 13.17

Measure the Rear Axle Angle

Place the inclinometer or spirit level protractor on a spacer and on the input yoke or on a smooth, flat portion of the axle tube (the "long" side, away from the bowl and near the suspension U-bolt) to measure the rear axle angle. Figure 13.18 and Figure 13.19.

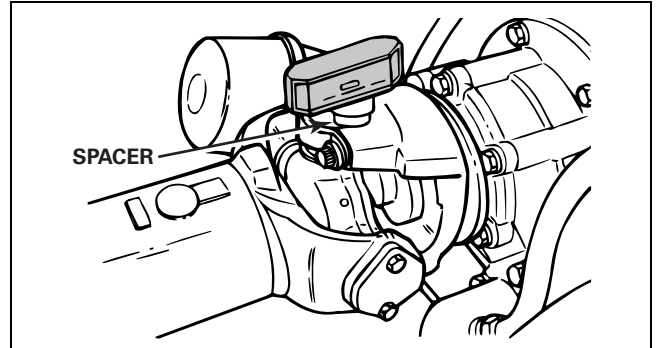

Figure 13.18

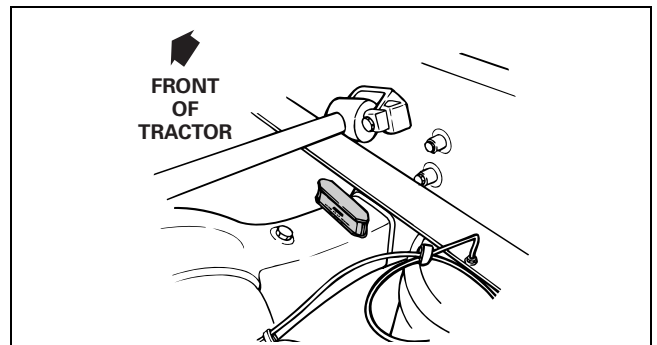

Figure 13.19

NOTE: Figure 13.19 is the preferred measurement method.

13 Measuring and Recording Driveline Angles

Write the measurement in the **Rear Axle Angle** box on the Data Gathering Worksheet. Figure 13.20.

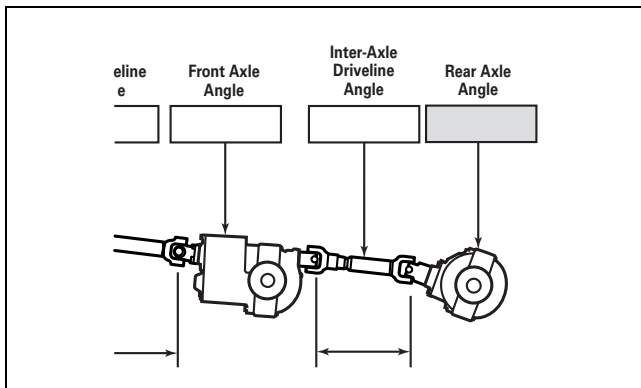

Figure 13.20

When You Finish Measuring the Driveline Angles

1. Set the tractor's parking brake.
2. Remove the blocks from the front tires.
3. You are now ready to enter the dimensions you recorded on the Data Gathering Worksheet into the Meritor Driveline Angle Analysis Program on the disk included with this manual. Figure 13.21.

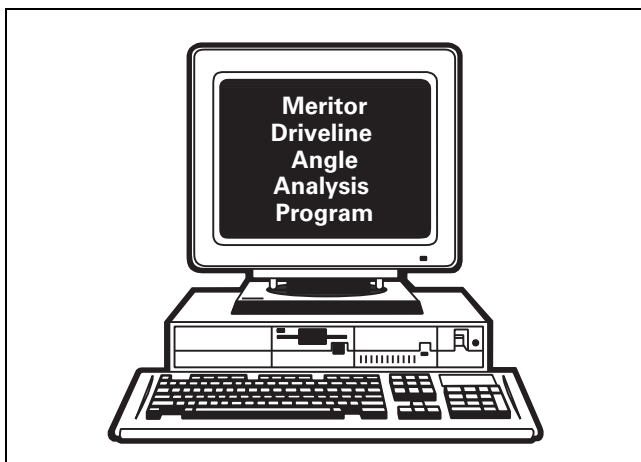

Figure 13.21

Manually Calculating Driveline Angles

If a computer and/or the Meritor Driveline Angle Analysis Program are not available, driveline joint angles can be calculated manually.

To calculate a joint angle, subtract the measured forward component angle from the measured rear component angle for that joint.

Example:

To calculate the first joint angle, you would use the angle measurements for the transmission and the first driveline.

- Transmission Angle = - 2.5°
- First Driveline Angle = - 1.0°
- First Joint Angle = - 1.0 - (- 2.5) = 1.5°

NOTE: Remember to include the negative sign for negative component angles. Always use a calculator to ensure accurate results with the correct negative or positive designations.

Adjustment

Hints for Driveline Set Up

After analyzing driveline angles, keep the following in mind when performing adjustment or replacement procedures.

- Keep operating angles below five degrees.
- Keep operating angles within one degree of each other.
- Typically, the hypoid Forward-Rear axle plane is the same as the Engine/Transmission plane (usually 3 to 3.5 degrees).
- Typically, the hypoid Rear-Rear axle plane is 10.5 to 11.5 degrees.

Recommended driveline angles are shown in Figure 13.22.

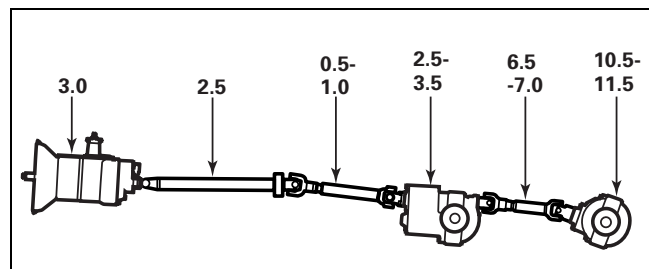

Figure 13.22

13 Measuring and Recording Driveline Angles

Driveline Angle Analysis Program

The Driveline Angle Analysis Program is used to determine the correct driveline angles for a Class 8 tractor with a two-piece main driveline and inter-axle. The program runs in Adobe Acrobat® Reader software. Refer to the Acrobat® Reader documentation for detailed information on using this program.

Open the Driveline Program

The Driveline Angle Analysis Program is on the CD-ROM included with this maintenance manual. To open the program, place the CD-ROM in the computer CD/DVD drive. The program will automatically launch. A menu page will appear on your screen with three options: View Manual, Run Program and Exit.

If the program does not automatically launch:

1. Click the Windows® Start icon. Click Run.
2. In the Run window, click Browse to find your system's CD/DVD drive (for example, [D:]); or enter your drive in the Open field. Click OK.
3. Double-click the auto folder. Double-click Driveline.exe.

Confirm the Vehicle Ride Height

Begin by confirming that the vehicle ride height is within specification.

1. Click on the **View Ride Height Measurement And Adjustment Procedures** field.
2. Follow the procedures to measure. If necessary, adjust the vehicle ride height.
3. Road test the vehicle to determine if the driveline condition still exists.
4. If the condition still exists, click on the field that applies to the vehicle's driveline configuration. There are currently four configurations covered by the Driveline Angle Analysis Program:
 - Two-piece tandem
 - Two-piece single
 - One-piece single
 - One-piece tandem
5. If the driveline condition was resolved by adjusting the ride height, click on the **Click Here To Exit This Program** field.

Measure the Driveline Angles

Measure the driveline angles listed on the Data Gathering Sheet that apply to the vehicle's driveline configuration. Refer to the procedures in this section.

Clicking on the **PHOTO** buttons displays examples of where to measure each angle.

NOTE: Data Gathering Worksheets are provided at the end of this manual. A worksheet can be taken to the vehicle, where you can record the relevant information.

Enter the Data

1. Enter the following optional information in the appropriate fields at the top of the screen. Figure 13.23.

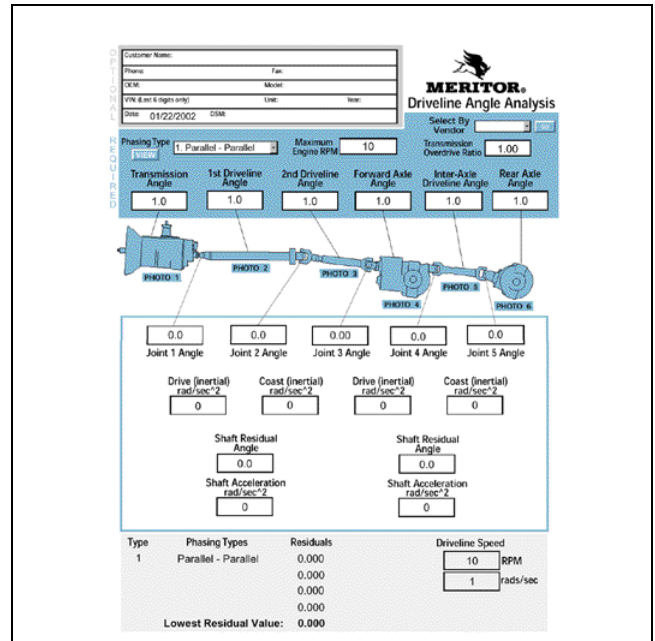

Figure 13.23

- Customer name and phone numbers
- OEM
- Model
- VIN
- Unit
- Year
- DSM name

13 Measuring and Recording Driveline Angles

NOTE: You must correctly enter information in Step 2 through Step 5 to obtain a correct analysis. If fields are left blank, you will not obtain an analysis.

2. Enter the maximum engine RPM. Figure 13.23.
3. Enter the transmission overdrive ratio. This value should be less than 1. For direct drive applications, enter 1. Figure 13.23. Click the **Select By Vendor** pull-down menu. Click on the **GO** button. The screen will display lists of transmissions by manufacturer. You can select your specific transmission model and ratio from these lists.

NOTE: The phasing type is not required for angle analysis of one-piece driveline configurations.

4. Enter the driveline phasing type. Click on the **VIEW** button next to the **Phasing Type** field to view examples of the four phasing types. Figure 13.24. Passing the cursor over the example windows will close them.

NOTE: Each driveline section is designated either PARALLEL or CROSSED, which is determined by the position of the yokes at either end of the section. If the yoke lugs on the two yokes are aligned, the section is PARALLEL. If the yoke lugs are not aligned (opposite or crossed), the section is CROSSED. Both sections are considered when determining the phasing type.

There are four driveline phasing types: Figure 13.25.

- Type 1: Parallel-Parallel
- Type 2: Crossed-Parallel
- Type 3: Parallel-Crossed
- Type 4: Crossed-Crossed

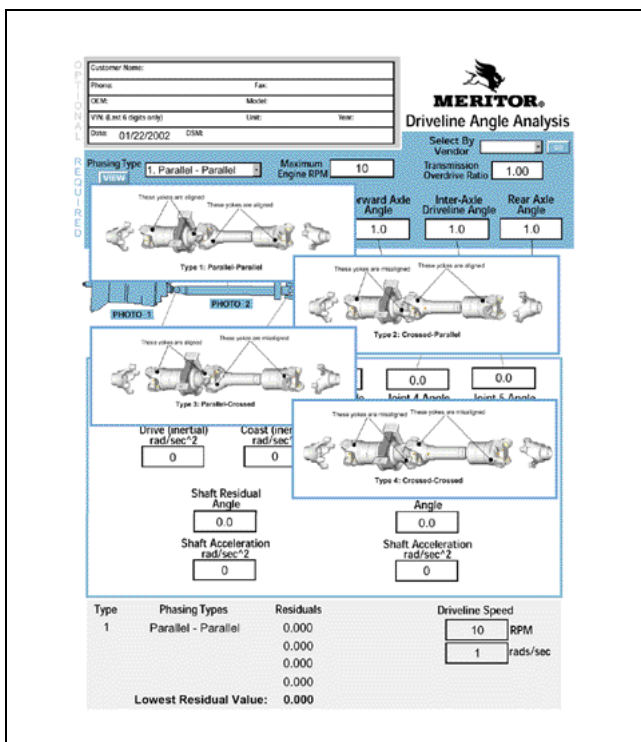

Figure 13.24

13 Measuring and Recording Driveline Angles

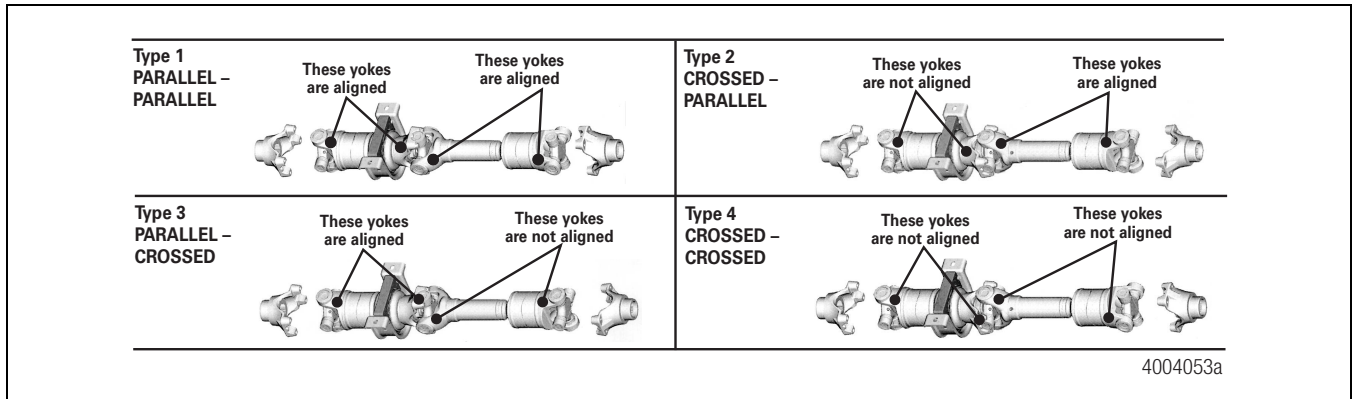

Figure 13.25

5. Enter the driveline angle values that you measured on the vehicle.
6. After you've entered all of the required information, click anywhere on the screen to complete the calculations. Values will appear in the driveline analysis fields, which are located below the driveline diagram. Values shown in red are not acceptable and must be corrected.
 - **If some values are shown in red:** Click the **Exceeds . . . field** located beneath the data fields, to display the troubleshooting boxes.

14 Special Tools



**YOKE BEARING CUP
INSTALLATION
(PRESS ASSEMBLY)
SPX KENT-MOORE
TOOL NUMBER J-42368-3**

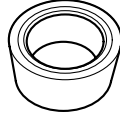

**BEARING CUP
BUSHING RECEIVER
SPX KENT-MOORE
TOOL NUMBER J-42368-2**

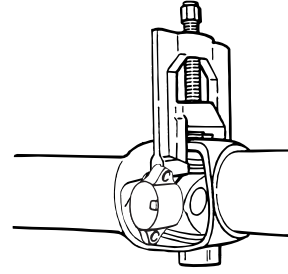

**UNIVERSAL JOINT PULLER
TIGER TOOL NUMBER 10102**

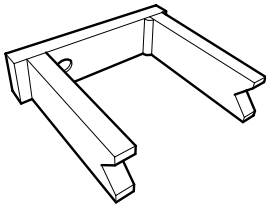

**BRIDGE
SPX KENT-MOORE
TOOL NUMBER
J-42368-1**

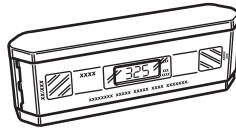

**ELECTRONIC
PROTRACTOR
SPX KENT-MOORE
TOOL NUMBER J-38460-A**

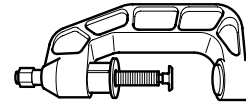

**UNIVERSAL JOINT PRESS
SPX KENT-MOORE
TOOL NUMBER 10707**

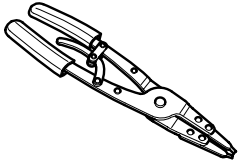

**SNAP RING PLIERS
SPX KENT-MOORE
TOOL NUMBER J-44676-1**

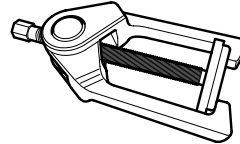

**YOKE BEARING
CUP INSTALLER
SPX KENT-MOORE
TOOL NUMBER
J-44516**

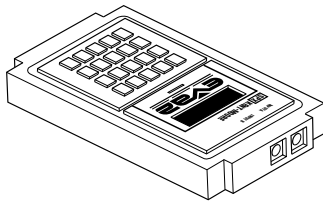

**EVA 2
VIBRATION ANALYZER
SPX KENT-MOORE
TOOL NUMBER
J-38792-A AND
J-45733**

Refer to the Service Notes page on the front inside cover of this manual for information on how to obtain these tools.

15 Glossary

Definitions

Bearing Stub — A splined stub that is pressed into and welded onto the tubing of a non-slip coupling shaft assembly.

Brinelling — Grooves worn into a cross and bearing kit trunnion by the needle rollers due to insufficient lubrication, excessive load or incorrect driveline angles.

Cardan Universal Joint — A mechanical device in which a cross and bearing kit connects yokes of a driving and a driven shaft.

Cross — The cross-shaped “body” of a universal joint kit.

Cross and Bearing Kit — Cross-shaped body with swivel bearings over each end that joins two driveline yokes in a Cardan universal joint. Cross and bearing kits are sometimes referred to as a “universal joint” or “universal joint kit.”

End Yoke — A yoke mounted to an input or output transmission shaft or axle shaft and secured by a nut and washer.

Galling — A transfer or displacement of metal. Galling can be caused by lack of lubricant, incorrect lubrication or excessive loads.

Gear Efficiency (e) — Ratio of power out of a gear set and the power provided into that gear set.

Hinging-Loose Condition — Usually within a slip section, which causes vibration through the driveline.

Needle Cup — A cross and bearing component kit that fits over the trunnion and holds the needle rollers.

Needle Rollers — Cylindrical bearings positioned around the bore of the needle cup that enable the bearing to rotate freely on the trunnion.

Non-Slip Coupling Shaft Assembly — A driveline of fixed length consisting of a weld yoke, tubing, bearing stub, center bearing kit and an end yoke with splined hole.

Operating Angle — The angle defined by the intersection of the centerlines of two shafts connected by a universal joint.

Permalube™ Universal Joint — A permanently lubricated and sealed universal joint that does not require regular lubrication.

Permalube™ Driveline — A driveline incorporating permanently lubricated universal joints with a permanently lubricated and sealed slip section. The entire assembly does not require regular lubrication.

Phasing — Correct alignment between yokes at each end of a driveline.

Round Bearing — A type of bearing cup used in cross and bearing kits for Cardan universal joints.

Runout — A condition in which a component's radius dimensions vary when the component is rotated. Excessive runout can negatively affect driveline operation.

Slip Yoke — A driveline assembly component that allows for driveline length changes by absorbing axial (backward-forward) movement of the driveline caused by axle articulation.

Standard Slip Assembly — A driveline assembly consisting of a slip yoke, spline plug, tubing and weld yoke.

Torsional Acceleration — Excessive rotation speed in an individual section of the driveline. Usually due to incorrect phasing.

Trunnion — Ground surfaces of the universal joint crossover in which the bearing cups fit.

Universal Joint — A joint providing a flexible coupling that allows torque transmission and rotary motion from one shaft to another, as well as angular changes in shaft alignment.

Welch Plug — A plate or cup used to seal the hole in the throat of a slip yoke and retain grease in the spline area.

Weld Yoke — A type of permanent fitting, welded to one or both ends of a driveline, designed for a specific combination of tubing and universal joint kit.

Wing Bearing — A type of bearing cup used in cross and bearing kits for specific types of yokes in Cardan universal joints. The cup has two flanges through which drilled or threaded holes extend to allow for cross and bearing kit mounting.

Important Information

Data Gathering Sheets

Customer Name:		
Phone: ()	Fax: ()	
OEM:	Model:	
VIN: (Last 6 digits only)	Unit:	Year:
Date:	DSM:	



Phasing Type	<input type="text"/>	Transmission Angle	<input type="text"/>	1st Driveline Angle	<input type="text"/>	2nd Driveline Angle	<input type="text"/>	Front Axle Angle	<input type="text"/>	Inter-Axle Driveline Angle	<input type="text"/>	Rear Axle Angle	<input type="text"/>
Maximum Engine RPM	<input type="text"/>												
Transmission Top Gear Ratio	<input type="text"/>												
Rear Suspension Ride Height	<input type="text"/>												
Maximum Engine HP	<input type="text"/>												
Clutch Model	<input type="text"/>												
Transmission Model	<input type="text"/>												
Main Driveline Series	<input type="text"/>												
Axle Model	<input type="text"/>	I/A Driveline Series	<input type="text"/>	Tire Size	<input type="text"/>								
Ratio	<input type="text"/>												

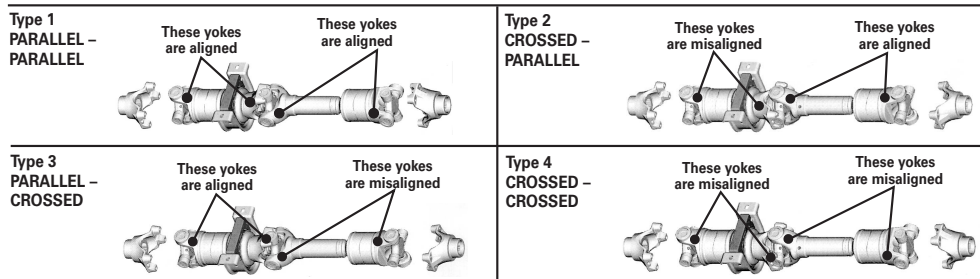

Before you measure a component, go to the side of the vehicle and look at the driveline:

- If the **FRONT** of the component is **HIGHER** than the **REAR** of the component, the dimension will be **positive (+)**.
- If the **FRONT** of the component is **LOWER** than the **REAR** of the component, the dimension will be **negative (-)**.

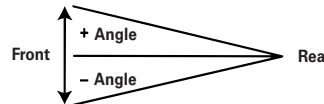

Assumptions

1. Drivelines are in the same plane. The top view shows all drivelines in a straight line.

For drivelines outside of the same plane, measure the offsets of each joint to the frame. Measure joint center to joint center lengths of each shaft. Fax this information to ArvinMeritor's Customer Service Center at 248-435-5580 or call the Center at 800-535-5560 for assistance.

2. Drivelines are balanced according to Meritor's driveline specifications.

Customer Name:		
Phone: ()	Fax: ()	
OEM:	Model:	
VIN: (Last 6 digits only)	Unit:	Year:
Date:	DSM:	



Driveline Angle Analysis Data Gathering Sheet Two-Piece, Single

Phasing Type	<input type="text"/>	Transmission Angle	<input type="text"/>	1st Driveline Angle	<input type="text"/>	2nd Driveline Angle	<input type="text"/>	Rear Axle Angle	<input type="text"/>			
Maximum Engine RPM	<input type="text"/>											
Transmission Top Gear Ratio	<input type="text"/>											
Rear Suspension Ride Height	<input type="text"/>											
Maximum Engine HP	<input type="text"/>											
Clutch Model	<input type="text"/>											
Transmission Model	<input type="text"/>											
Main Driveline Series	<input type="text"/>											
Driveline Length (Center to Center)	<input type="text"/>								Driveline Length (Center to Center)	<input type="text"/>		
Axle Model	<input type="text"/>								I/A Driveline Series	<input type="text"/>	Tire Size	<input type="text"/>
Ratio	<input type="text"/>											

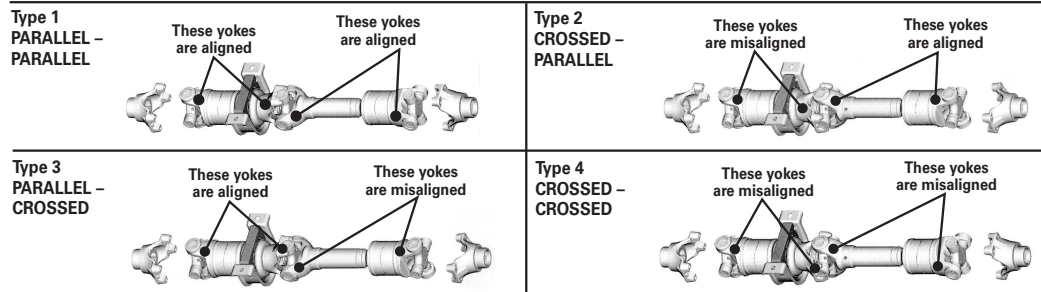

Before you measure a component, go to the side of the vehicle and look at the driveline:

- If the **FRONT** of the component is **HIGHER** than the **REAR** of the component, the dimension will be **positive (+)**.
- If the **FRONT** of the component is **LOWER** than the **REAR** of the component, the dimension will be **negative (-)**.

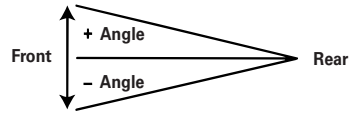

Assumptions

- 1. Drivelines are in the same plane. The top view shows all drivelines in a straight line.**
 For drivelines outside of the same plane, measure the offsets of each joint to the frame. Measure joint center to joint center lengths of each shaft. Fax this information to ArvinMeritor's Customer Service Center at 248-435-5580 or call the Center at 800-535-5560 for assistance.
- 2. Drivelines are balanced according to Meritor's driveline specifications.**

Customer Name:		
Phone: ()	Fax: ()	
OEM:	Model:	
VIN: (Last 6 digits only)	Unit:	Year:
Date:	DSM:	



**Driveline Angle Analysis
Data Gathering Sheet
One-Piece, Tandem**

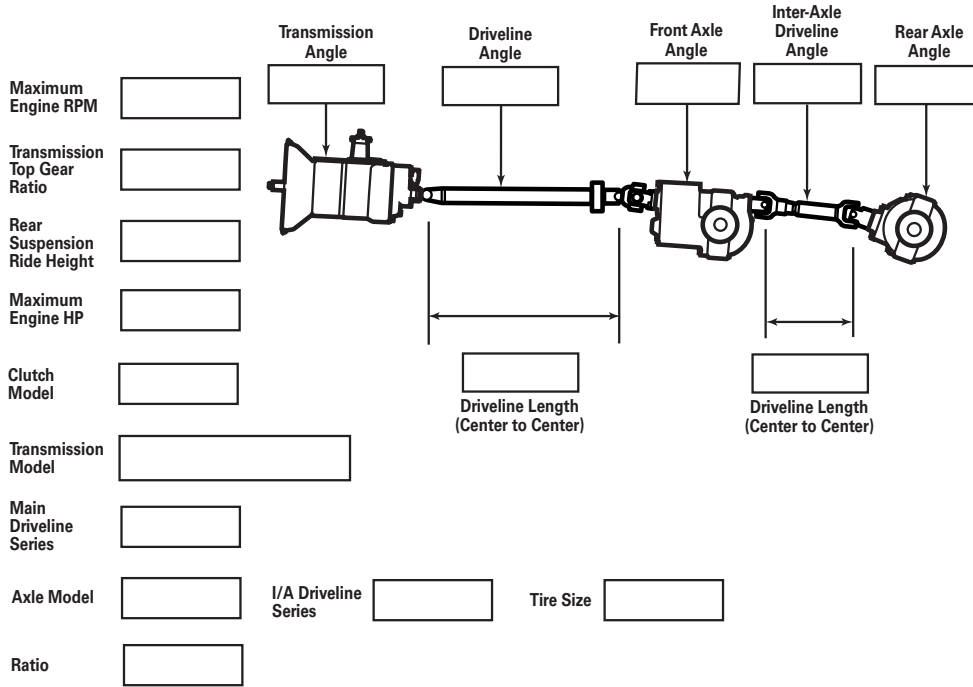

Before you measure a component, go to the side of the vehicle and look at the driveline:

- If the **FRONT** of the component is **HIGHER** than the **REAR** of the component, the dimension will be **positive (+)**.
- If the **FRONT** of the component is **LOWER** than the **REAR** of the component, the dimension will be **negative (-)**.

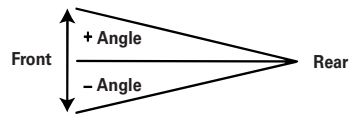

Assumptions

1. Drivelines are in the same plane. The top view shows all drivelines in a straight line.

For drivelines outside of the same plane, measure the offsets of each joint to the frame. Measure joint center to joint center lengths of each shaft. Fax this information to ArvinMeritor's Customer Service Center at 248-435-5580 or call the Center at 800-535-5560 for assistance.

2. Drivelines are balanced according to Meritor's driveline specifications.

Customer Name:		
Phone: ()	Fax: ()	
OEM:	Model:	
VIN: (Last 6 digits only)	Unit:	Year:
Date:	DSM:	



**Driveline Angle Analysis
Data Gathering Sheet
One-Piece, Single**

		Transmission Angle	1st Driveline Angle	Rear Axle Angle		
Maximum Engine RPM	<input type="text"/>	<input type="text"/>	<input type="text"/>	<input type="text"/>		
Transmission Top Gear Ratio	<input type="text"/>					
Rear Suspension Ride Height	<input type="text"/>					
Maximum Engine HP	<input type="text"/>					
Clutch Model	<input type="text"/>					
Transmission Model	<input type="text"/>					
Main Driveline Series	<input type="text"/>					
Driveline Length (Center to Center)	<input type="text"/>					
1/A Driveline Series	<input type="text"/>					
Axle Model	<input type="text"/>				Tire Size	<input type="text"/>
Ratio	<input type="text"/>					

Before you measure a component, go to the side of the vehicle and look at the driveline:

- If the **FRONT** of the component is **HIGHER** than the **REAR** of the component, the dimension will be **positive (+)**.
- If the **FRONT** of the component is **LOWER** than the **REAR** of the component, the dimension will be **negative (-)**.

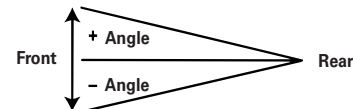

Assumptions

1. Drivelines are in the same plane. The top view shows all drivelines in a straight line.

For drivelines outside of the same plane, measure the offsets of each joint to the frame. Measure joint center to joint center lengths of each shaft. Fax this information to ArvinMeritor's Customer Service Center at 248-435-5580 or call the Center at 800-535-5560 for assistance.

2. Drivelines are balanced according to Meritor's driveline specifications.



Meritor Heavy Vehicle Systems, LLC
2135 West Maple Road
Troy, MI 48084 USA
800-535-5560
arvinmeritor.com

Copyright 2004
ArvinMeritor, Inc.

Printed in USA

Revised 02-04
Maintenance Manual MM-96147 (16579/24240)

ArvinMeritor™