

11 LOW POWER CONCERN

Section	Page
11.1 FACTORS THAT AFFECT WHEEL HORSEPOWER	11- 3
11.2 LOW HORSEPOWER INTERVIEW	11- 6
11.3 AERATED FUEL	11-13
11.4 HIGH FUEL PRESSURE	11-15
11.5 HIGH FUEL TEMPERATURE RETURN	11-18
11.6 RESTRICTED AIR CLEANER ELEMENT	11-20
11.7 RESTRICTED OR CRACKED CHARGE AIR COOLER OR LEAKING INTAKE MANIFOLD	11-21
11.8 FAULTY EXHAUST SYSTEM	11-23
11.9 HIGH INLET AIR TEMPERATURE	11-25
11.10 HIGH ALTITUDE OPERATION	11-27
11.11 INCORRECT CAMSHAFT TIMING	11-29
11.12 VERIFICATION OF POWER WITH CHASSIS DYNAMOMETER	11-30

11.1 FACTORS THAT AFFECT WHEEL HORSEPOWER

The factors affecting wheel horsepower are listed in Table 11-1.

To begin low horsepower diagnosis, refer to section 11.2

Factors	Considerations
DDEC Power Rating	Is the correct power rating programmed into the ECM? Is the driver aware of the effects that cruise power, or the lack of cruise power has on perceived power?
Road Speed Setting	Is the road speed setting causing a perceived lack of power?
Crank Case Overfilled	If the crank case level is too high, there will be a loss of power due to churning losses created by the crank shaft throws contacting the oil.
Fuel Temperature	Make sure there is sufficient fuel supply (at least 1/3 of normal capacity) in the fuel tanks. Check fuel temperature. For every 10°F increase in fuel inlet temperature above 100°F, the engine will experience a power loss of up to one percent.
Fuel Blend (specific gravity)	Check the specific gravity of the fuel/vehicle system. A good number 2 diesel fuel has a specific gravity of 0.840 or higher @ 60°F. It should be noted that No. 1 diesel fuel can reduce horsepower to 7% less than No. 2 fuel. Blends of No. 1 and No. 2 (common in winter) will produce less horsepower, depending on the percent of the blend. This is a common concern when dealing with low power complaints in cold climate locations.
Fuel Filter Restriction	Check for fuel flow restrictions which can be caused by fuel heaters, water separators, fuel flow meters, undersize or improperly routed/damaged fuel lines, faulty check valves, contaminated fuel filters or high fuel pressure resulting from a plugged restricted fitting or regulator valve. Replacing the fuel filter is often the best recommendation in lieu of testing for the filter condition.
Fuel Shut-Off Valve Position	Make sure the fuel shut-off valve is fully open.
Fuel System Leak	Fuel system leaks which result in aerated fuel are normally caused by a leak at the connections and /or filters between the suction side of the fuel pump to the supply tank and not between the pressure side of the pump and engine.
Fuel Tank Vent Restriction	A plugged fuel tank vent will create a vacuum in the tank and result in a loss in fuel pressure at the injectors. This will reduce fuel delivery rate.
Air in Fuel	Aerated fuel, caused by a fuel system leak, will result in reduced fuel delivery and late injection timing.
Plugged or Cracked Fuel Tank Stand Pipe	If the fuel tank stand pipe is plugged by a shop rag, fuel delivery will be restricted. A cracked stand pipe will allow air to enter the fuel system and reduce fuel flow and cause late injection timing.
Faulty Injector	A faulty injector will limit fuel delivery and alter the combustion process such that power is compromised.
Injector Codes	Incorrect injector codes will limit fuel delivery.
Valve Lash	Incorrect valve lash will alter the combustion process such that power is compromised.

Factors	Considerations
Camshaft Timing	Incorrect cam timing will alter the combustion process such that power is compromised.
Air Flow Restriction	Air flow must not be inhibited by plugged filter, or inadequate inlet air duct shrouding.
Faulty Turbocharger	A turbocharger that has wheel rubbing, oil leaks, bent blades, etc. will not provide adequate air supply.
Temperature Controlled Fan	A faulty thermo control will cause the fan to be locked on and drain power on a continuous basis.
Air System Leaks (gaskets and seals)	Air system leaks will result in insufficient air for optimum combustion.
Charge Air Cooler Leak	Air system leaks will result in insufficient air for optimum combustion.
Climate (fresh air temp)	The maximum allowable temperature rise from ambient air to engine inlet is 30°F. Undersized or dirty air cleaner element, as well as damaged or obstructed air inlet piping can cause low power. Make sure under-hood hot air is not being taken in. Pressure drop across the air to air charge cooler should be checked (3.0 in. Hg maximum from turbo discharge to intake manifold). Check turbocharger boost pressure and compare to specification.
Altitude Performance	Site altitude has an effect on engine horsepower. Expect approximately 2% loss in power when operating at an altitude of 1 mile, relative to sea level.
DDEC Parameter Settings	Make sure vehicle settings such as: axle ratio, tire size, top gear ratio, etc. are set correctly to avoid a false sense of engine performance.
EGR Valve	A misadjusted or malfunctioning EGR valve will alter the amount of oxygen available for combustion as well as introduce inert gas that does not promote combustion.
Exhaust Restriction	A damaged, undersized, or otherwise restricted muffler or exhaust system can result in high exhaust back pressure. Refer to the engine specification sheets for maximum allowable pressure.
Delta P Sensor	The Delta P sensor, along with the exhaust temperature, determines EGR flow rate. A faulty delta P sensor will cause the EGR system to malfunction and alter the amount of oxygen available for combustion as well as introduce inert gas that will not promote combustion.
Barometric Pressure Sensor	The engine will transition between EGR and boost mode at an altitude of 6500 ft. Altitude is determined by the Barometric Pressure Sensor located on the engine. A faulty Barometric Pressure Sensor will compromise the availability of boost pressure.
VPOD and Supply Lines	Variable pressure output devices control the variable geometry turbo vanes and EGR valve position. Improper turbo vane or EGR valve positions will alter the air flow system balance and subsequently the combustion process.
Air Compressor Leak	An air compressor leak will cause the air compressor to work more and increase the parasitic load on the engine.
Air Conditioner Leak	An air conditioner leak will cause the air conditioner to work more and increase the parasitic load on the engine.
Excessive Play in Power Steering System	Continuous movement of the steering wheel will call for continuous work by the power steering unit. This will increase the parasitic load on the engine.

Factors	Considerations
Alternator Load	Excessive use of vehicle electrical power will cause increased use of the alternator. This will increase the parasitic load on the engine.
Tire Pressure	Under inflated tires will significantly increase driveline resistance to rotation.
Trailer Aerodynamics/Alignment	A trailer that has poor aerodynamics or has misaligned axles (causing dog tailing) will significantly increase vehicle inertia and resistance to forward motion.
Vehicle Payload	As vehicle loading increases, vehicle inertia and resistance to forward motion increases.
Winter-front Installation	Improper installation or usage of a winter-front will result in extremely high intake air temperatures and reduced mass flow of air into the combustion chamber.
Vehicle Application	Unusual applications such as triple drive axles, PTO's, pumps, high air compressor duty cycle, etc., will have higher parasitic losses resulting in less horsepower at the wheels.

Table 11-1 Factors Affecting Wheel Horsepower

11.2 LOW HORSEPOWER INTERVIEW

To determine if low horsepower is causing a power concern, use the driver questionnaire, the troubleshooting tree, and the low power troubleshooting chart.

11.2.1 Driver Questionnaire

This section should serve as a guideline for the technician.

For an example of the driver questionnaire see Figure 11-1.

Engine Diagnostic Questionnaire		RO #	
Customer Name: _____			
Contact Person: _____			
LOW POWER/POOR FUEL ECONOMY:			
Does check engine light come on?	Yes	No	
Does the engine miss, run rough, hard starting?	Miss	Run Rough	Hard Starting
Power Loss sudden or has decreased with time?		Sudden	Decreased with time
Excessive engine exhaust smoke (see #3)?	Yes	No	
If yes, what color?	Black	Blue	White
Heard any unusual engine noise? Yes _____		No	
Power loss occurs on _____	Foot	Cruise	Both
Have injectors been replaced recently?	Yes	No	
When was last tune up? _____	Mileage _____	Date _____	
Comments: _____			

ANY INTERMITTENT PROBLEMS:			
Last time it happened: _____			
Does the check engine light come on?		Yes	No
Does the problem occur only in damp or rainy conditions?		Yes	No
When the vehicle hits a bump or rough road?		Yes	No
Does the engine:	Miss	Drop to idle	Quit running
	Gauge Sweep	Hard Starting	
Comments: _____			

e.g. Does the driver do anything to correct the problem?			
SMOKING:			
Where is the smoke coming from? _____			
What color is the smoke?	Blue	Black	White
			BI/White
When does it smoke?	Start-up	Cold Eng.	Hot Eng.
			U.Load
Have you noticed any oil consumption?		Yes	No
Have you noticed a miss in the engine?		Yes	No
Was the smoke intermittent?-	Start all at once?	Been getting worse over time?	
Comments: _____			

COOLANT LOSS			
Has the oil level risen?	Yes	No	
Have you noticed any coolant leaks?	Yes	No	
How often do you add coolant?	How Much? _____		
What kind of coolant do you use? _____			
What kind of inhibitor do you use? _____			
Comments: _____			

OIL CONSUMPTION:			
How much oil are you adding?	How often (miles)? _____		
Have you noticed any oil leaks?		Yes	No
Have you noticed any smoke out the exhaust?		Yes	No
	At Idle	Light or no load	Heavy load
How often do you change oil? _____	What Brand? _____		
Have you changed brands recently?		Yes	No
How & when do you check your oil? _____			
Comments: _____			

44272

Figure 11-1 Driver Questionnaire

11.2.1.1 Driver Questionnaire

Ask the driver to answer the following questions before attempting to repair an intermittent problem, or a problem with symptoms but no diagnostic codes. Use this and the response as a guideline. Refer to section 11.2.1.2, “Questionnaire Response Guideline.”

1. How often does the problem occur? Can you and the driver take the vehicle and demonstrate the problem in less than 30 minutes?
2. Has the vehicle been to other shops for the same problem? If so, what was done there?
3. Did the radio, dash gages, or lights momentarily turn OFF when the problem occurred?
4. Does the problem occur only at specific operating conditions? If so, at what load? Is it light, medium, or heavy?
5. Does the problem occur at a specific engine operating temperature? If so, at what engine temperature?
6. Does the problem occur at a specific engine operating altitude? If so, at what altitude?
7. Does the problem occur only when above or below specific outside temperatures? If so, what temperature range?
8. Does the problem occur during other conditions e.g. during or after rain, spray washing, snow?
9. Did the problem occur at a specific vehicle speed? If so, at what vehicle speed?
10. Does the problem occur at specific engine RPM? If so, at what engine RPM?

11.2.1.2 Questionnaire Response Guideline

The following are typical responses to the driver questionnaire:

 WARNING: PERSONAL INJURY
To avoid injury from loss of vehicle/vessel control, the operator of a DDEC equipped engine must not use or read any diagnostic tool while the vehicle/vessel is moving.

1. If the problem is repeatable, take the vehicle for a drive with Detroit Diesel Diagnostic Link (DDDL) connected and note the conditions when the problem occurs. Be prepared to take snapshot data using DDDL. **Ensure you operate the vehicle after correcting the problem and duplicate the operating conditions before releasing the unit, in order to verify the problem is corrected.**
2. If the vehicle has been to other shops for the same problem, call the other shops and find out what has been done. Avoid replacing the same components again unless absolutely sure they are the problem! It is unlikely a component will fail again following a recent replacement.

3. If other vehicle devices are affected, this indicates there may be something wrong with the ignition wiring.
4. Operate the engine under similar load and temperature conditions. Check the fuel system for restrictions, primary filter, and fuel tanks for foreign objects blocking the fuel supply. Also, check the air system. Utilize the DDDL snapshot feature.
5. Operate the engine at this temperature while attempting to duplicate the problem. Use the DDDL snapshot feature.
6. It may not be possible to duplicate the fault or problem unless you can operate the unit in a similar environment. You may want to talk to the Customer Support Center, or a dealer in that area. They may have helpful experience.
7. If possible, troubleshoot the problem in a similar temperature range.
8. If the problem seems to occur during or after the engine is subjected to rain/spray washing, thoroughly inspect the connectors for moisture entry.
9. If the problem occurs at a specific vehicle speed, check the parameters affecting vehicle speed to verify they are programmed close to the vehicle speed where the problem occurs. Check vehicle speed and watch DDDL (snapshot) for changes to see if the pulse wheel (VSS signal) is loose.
10. If the problem occurs at a specific engine rpm, unplug the oil, coolant, and air temperature sensors, and note any changes to the problem. Gather this data and contact DDC Customer Support Center at 313-592-5800.

11.2.2 Troubleshooting Tree

Following is the troubleshooting tree for low horsepower:

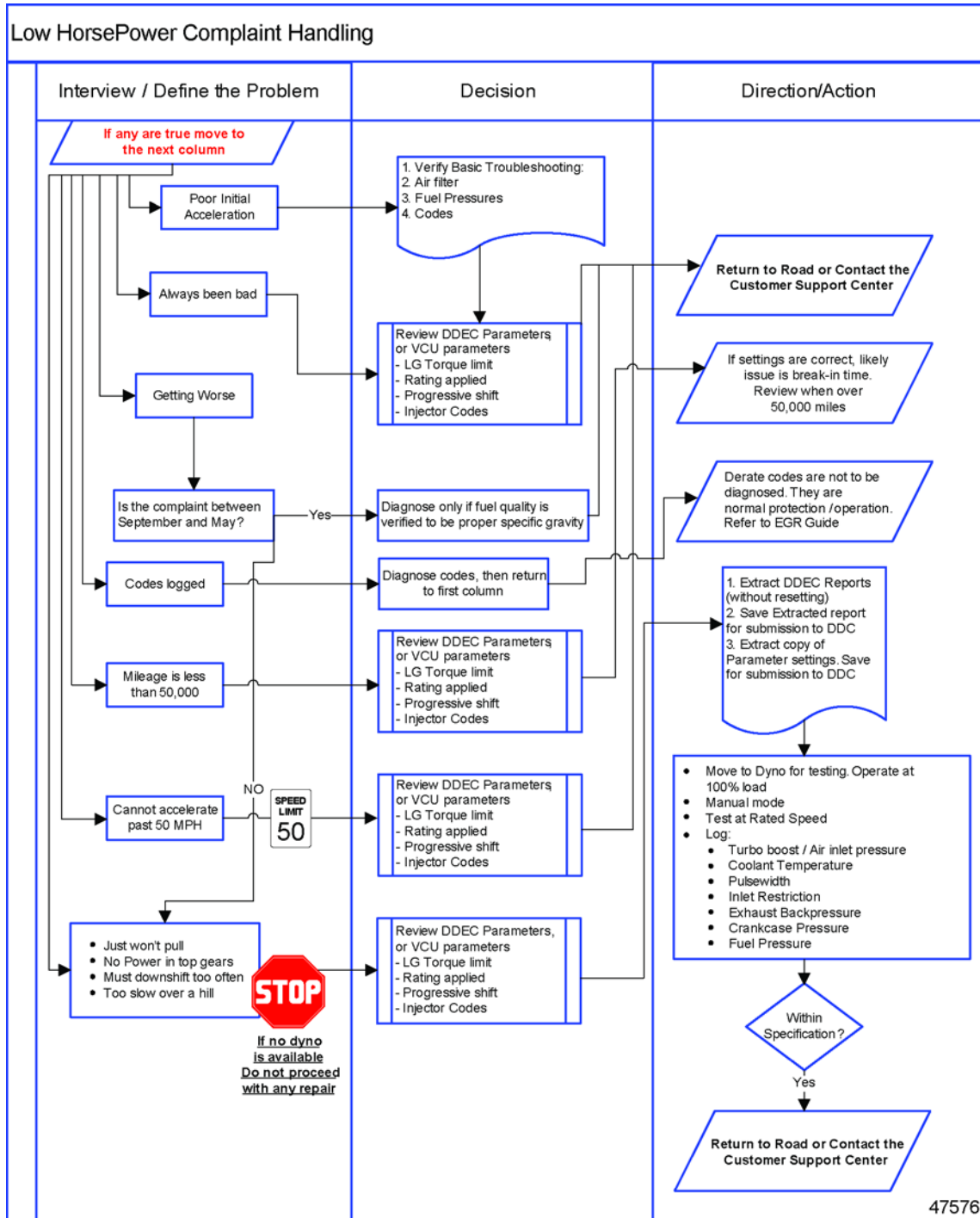

Figure 11-2 Troubleshooting Tree

11.2.3 Low Power Troubleshooting Chart

There are three basic checks that should be performed:

- Check for active/historic codes. Refer to DDC pocket card 7SE460 for select EGR engine codes. All causes need to be checked once the fault is identified. Record faults on the Application For Adjustment (AFA) claim, if there is to be a claim.
- Check the DDEC parameters, progressive shift settings, torque limiting values, and injector codes. Are they correct? Is proper rating applied? If vehicle is new, is it spec'd correctly?
- Check that the dyno-measured power is within DDC specifications as Listed in Table 11-4 and Table 11-5 for minimum acceptable wheel HP data. Record data on AFA claim.

NOTE:

Service information letter instructions published following the date of this document take precedence.

Possible causes of low power and symptoms are listed in Table 11-2.

Possible Causes	Symptoms						
	Loss of Power	Misfires	Poor Acceleration	Erratic Idle	Engine Dies	Black Smoke	Excessive Oil Consumption
Fuel Filter Restriction refer to section 11.1	X	X	X		X		
Fuel Shut-Off Valve not Open refer to section 11.1	X	X	X	X			
Air in the Fuel refer to section 11.3	X	X	X	X			
Faulty Injector(s) refer to section 11.1	X	X	X	X	X	X	
Faulty Turbocharger refer to section 11.1	X		X			X	
EGR Valve* refer to section 11.1	X		X	X		X	
Delta P Sensor or Plugged Lines* refer to section 11.1	X		X	X		X	
VPOD or Air Supply Lines* refer to section 11.1	X		X	X		X	
Charge Air Cooler Leak refer to section 11.7	X		X			X	

Possible Causes	Symptoms						
	Loss of Power	Misfires	Poor Acceleration	Erratic Idle	Engine Dies	Black Smoke	Excessive Oil Consumption
Intake or Exhaust Manifold Leak refer to section 11.7 and section 11.8	X		X			X	
Quality/Grade of Fuel refer to section 11.1	X	X	X	X		X	
High Fuel Temperature - Above 130°F refer to section 11.5	X		X				
Restricted Air Intake refer to section 11.1	X		X			X	
Crankcase Overfilled refer to section 11.1	X		X				X
Faulty Fan Operation, Always On refer to section 11.1	X		X				
Debris in Fuel Tank - Air Vent Plugged refer to section 11.1	X	X	X	X	X		

Table 11-2 Low Power Troubleshooting Chart

* Refer to the *Series 60 EGR Technician's Manual (7SE60)* for test procedures.

11.3 AERATED FUEL

To determine if aerated fuel is causing lack of power, perform the following steps:

1. Disconnect the fuel line return hose from the fitting located at the fuel tank; refer to OEM guidelines.
2. Place the open end of the fuel line into a suitable container.

 **CAUTION:**

To avoid injury before starting and running the engine, ensure the vehicle is parked on a level surface, parking brake is set, and the wheels are blocked.

 **CAUTION:**

To avoid injury from inhaling engine exhaust, always operate the engine in a well-ventilated area. Engine exhaust is toxic.

3. Start and run the engine.
4. Operate the engine at 1000 rpm.
5. Visually check to see if air bubbles are rising to the surface of the fuel within the container.
 - [a] If air bubbles are not present, shut down engine, check for high fuel pressure; refer to section 11.4.
 - [b] If air bubbles are present, shut down engine; refer to section 11.3.1.

11.3.1 Aerated Fuel Resolution

Perform the following steps to resolve aerated fuel:

1. Tighten all fuel line connections between the fuel tank and fuel pump; refer to OEM guidelines.
2. Visually inspect all fuel lines between the fuel tank and fuel pump for leaks.
3. Repair damaged components as required; refer to OEM guidelines.
4. Verify aerated fuel resolution; refer to section 11.3.1.1.

11.3.1.1 Test the Engine with Aerated Fuel Resolution

Perform the following steps to determine if aerated fuel resolution resolved lack of power condition:

1. Start and run the engine.

2. Run the engine at idle with a no-load for approximately 5 minutes, allowing the engine coolant to reach normal operating range.
3. Test drive the vehicle to ensure lack of power has been resolved.
 - [a] If no lack of power occurred during the test drive, no further troubleshooting is required. Shut down the engine.
 - [b] If lack of power occurred during the test drive, shut down the engine. Check for high fuel pressure; refer to section 11.4.

11.4 HIGH FUEL PRESSURE

To determine if high fuel pressure is causing lack of power, perform the following steps:

1. Remove the Supply Fuel Temperature Sensor (SFT Sensor) fitting from the fuel pump. see Figure 11-3 for SFT Sensor.

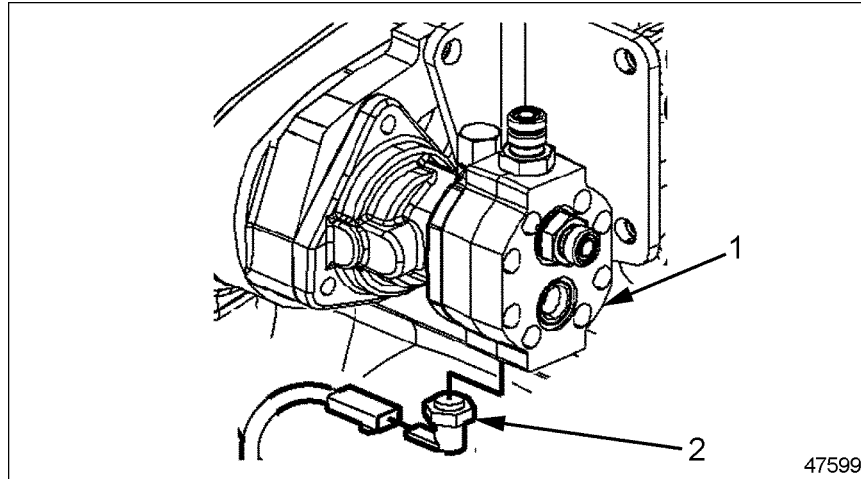

1. Fuel Pump

2. Fitting

Figure 11-3 **Supply Fuel Temperature Sensor**

2. Attach a calibrated gauge capable of reading 0 - 345 kPa (0 - 50 psi) to the fuel pump.

⚠ CAUTION:

To avoid injury before starting and running the engine, ensure the vehicle is parked on a level surface, parking brake is set, and the wheels are blocked.

⚠ CAUTION:

To avoid injury from inhaling engine exhaust, always operate the engine in a well-ventilated area. Engine exhaust is toxic.

3. Start and run the engine to the speeds listed in Table 11-3 and record the fuel pressure:

NOTE:

When checking fuel pressure, start the engine, run at the speeds listed in Table 11-3, and record fuel pressure. Shut down the engine.

Engine Speed, rpm	Average Fuel Pressure, kPa (psi)
600	124 (18)
1200	145 (21)
1800	165 (24)
2100	186 (27)

Table 11-3 Fuel Pressure (DDEC V with Regulator)

4. Shut down the engine.
5. Remove the calibrated gauge from the fuel pump.
6. Reinstall the SFT Sensor, refer to the *Series 60 Service manual (6SE483)*, fuel system chapter.
7. Analyze the measured fuel pressure readings.
 - [a] If the fuel pressure is within specification listed in Table 11-3, check for high fuel temperature return; refer to section 11.5.
 - [b] If the fuel pressure is greater than specifications listed in Table 11-3, refer to section 11.4.1.

11.4.1 Combination Check Valve/Regulator Replacement

Perform the following steps to replace the combination check valve/regulator:

1. Remove the combination check valve/regulator; refer to appropriate service manual, fuel system chapter.

2. Install a new combination check valve/regulator; refer to appropriate service manual, fuel system chapter.
3. Verify new combination check valve/regulator replacement; refer to section 11.4.1.1.

11.4.1.1 Test the Engine with Replaced Combination Check Valve/Regulator

Perform the following steps to determine if the replaced combination check valve/regulator resolved lack of power condition:

1. Start and run the engine.
2. Run the engine at idle with a no-load for approximately 5 minutes, allowing the engine coolant to reach normal operating range.
3. Test drive the vehicle to ensure lack of power has been resolved.
 - [a] If no lack of power occurred during the test drive, no further troubleshooting is required. Shut down the engine.
 - [b] If lack of power occurred during the test drive, shut down the engine. Check for high fuel temperature return; refer to section 11.5.

11.5 HIGH FUEL TEMPERATURE RETURN

To determine if high fuel temperature return is causing lack of power, perform the following steps:

1. Test for high fuel temperature return.
2. Analyze the high fuel temperature test results.
 - [a] If the return fuel temperature is less than or equal to 54°C (130°F), check for air cleaner restriction; refer to section 11.6.
 - [b] If the return fuel temperature is greater than 54°C (130°F), resolve the high fuel temperature return condition; refer to section 11.5.1.

11.5.1 High Fuel Temperature Resolution

Perform the following steps to resolve high fuel temperature return:

1. Remove and replace fuel filter(s); refer to *Series 60 Service manual (6SE483)*, fuel system chapter.
2. Inspect the combination check valve/regulator, replace if necessary; refer to *Series 60 Service manual (6SE483)*, fuel system chapter.
3. If equipped with a fuel cooler, refer to OEM for inspection guidelines.
4. Verify high fuel temperature repair; refer to section 11.5.1.1.

11.5.1.1 Test the Engine with Resolved High Fuel Temperature

Perform the following steps to determine if high fuel temperature repairs resolved lack of power condition:

 **CAUTION:**

To avoid injury before starting and running the engine, ensure the vehicle is parked on a level surface, parking brake is set, and the wheels are blocked.

 **CAUTION:**

To avoid injury from inhaling engine exhaust, always operate the engine in a well-ventilated area. Engine exhaust is toxic.

1. Start and run the engine.
2. Test drive the vehicle to ensure lack of power has been resolved.

- [a] If lack of power did not occur during the test drive, no further troubleshooting is required. Shut down the engine.
- [b] If lack of power occurred during the test drive, shut down the engine. Check for a restricted air cleaner element; refer to section 11.6.

11.6 RESTRICTED AIR CLEANER ELEMENT

To determine if a restricted air cleaner element is causing lack of power, perform the following steps:

1. Remove the air filter element from the air cleaner container; refer to OEM guidelines.
2. Visually inspect the air cleaner element for damage or clogging.
 - [a] If no damage or clogging is found, check the charge air cooler; refer to section 11.7.
 - [b] If damage or clogging is found; refer to section 11.6.1.

NOTE:

Replace the air filter, if close to a maintenance interval.

11.6.1 Air Filter Element Replacement

Perform the following steps to replace the air filter element:

1. Remove and replace the damaged or clogged air filter element; refer to OEM guidelines.
2. Verify air filter element replacement; refer to section 11.6.1.1.

11.6.1.1 Test the Engine with Replaced Air Filter Element

Perform the following steps to determine if the new filter element resolved lack of power:

 **CAUTION:**

To avoid injury before starting and running the engine, ensure the vehicle is parked on a level surface, parking brake is set, and the wheels are blocked.

 **CAUTION:**

To avoid injury from inhaling engine exhaust, always operate the engine in a well-ventilated area. Engine exhaust is toxic.

1. Start and run the engine.
2. Test drive the vehicle to ensure lack of power has been resolved.
 - [a] If lack of power did not occur during the test drive, no further troubleshooting is required. Shut down the engine.
 - [b] If lack of power occurred during the test drive, shut down the engine. Check the charge air cooler; refer to section 11.7.

11.7 RESTRICTED OR CRACKED CHARGE AIR COOLER OR LEAKING INTAKE MANIFOLD

To determine if a restricted or cracked charge air cooler or leaking manifold is causing lack of power, perform the following steps:

1. Attach air-to-air charge air cooler test kit, J-41473; refer to OEM guidelines.
2. Disconnect the air inlet hose from the outlet side of the turbocharger compressor housing; refer to appropriate service manual, air intake system chapter.
3. Attach the air-to-air cooler test kit adaptor plug to fit into the hose at the compressor connector; refer to OEM guidelines.
4. Attach an air pressure hose to the air chuck at the regulator and gradually pressurize the air inlet system to a pressure of 177 kPa (25 psi).
5. Apply a water and soap solution to each hose connection, across the face of the charge air cooler.
6. Apply a water and soap solution to the air intake manifold and cylinder head mating surface area.
7. Visually inspect all joints for air leaks and all charge air cooler welded surfaces for stress cracks.
 - [a] If charge air cooler leaks are present around the joints, replace the charge air cooler; refer to section 11.7.1.
 - [b] If the intake manifold leaks, repair intake manifold; refer to section 11.7.2.
 - [c] If neither charge air cooler nor intake manifold leaked, check the exhaust system; refer to section 11.8.
8. Inspect charge air cooler for leaks (hoses, clamps, etc.).

11.7.1 Charge Air Cooler Replacement

Perform the following steps to replace the charge air cooler:

1. Remove and replace the charge air cooler; refer to OEM guidelines.
2. If the intake manifold doesn't leak, verify replacement of the charge air cooler; refer to section 11.7.2.1.
3. If the intake manifold leaks, repair intake manifold; refer to section 11.7.2.

11.7.2 Air Intake Manifold Repair

Perform the following steps to repair the air intake manifold:

1. Remove the air intake manifold; refer to *Series 60 Service manual (6SE483)*, Air system chapter.

2. Inspect the air intake manifold; refer to *Series 60 Service manual (6SE483)*, Air system chapter.
3. Install the air intake manifold; refer to *Series 60 Service manual (6SE483)*, Air system chapter.
4. Verify repair of the intake manifold; refer to section 11.7.2.1.

11.7.2.1 Test the Engine with Replaced Charge Air Cooler and Air Intake Manifold

To determine if the repairs resolved the lack of power condition, perform the following steps:

 **CAUTION:**

To avoid injury before starting and running the engine, ensure the vehicle is parked on a level surface, parking brake is set, and the wheels are blocked.

 **CAUTION:**

To avoid injury from inhaling engine exhaust, always operate the engine in a well-ventilated area. Engine exhaust is toxic.

1. Start and run the engine.
2. Test drive the vehicle to ensure lack of power has been resolved.
 - [a] If no lack of power occurred during the test drive, no further troubleshooting is required. Shut down the engine.
 - [b] If lack of power occurred during the test drive, shut down the engine. Check the exhaust system; refer to section 11.8.

11.8 FAULTY EXHAUST SYSTEM

To determine if a faulty exhaust system is causing lack of power, perform the following steps:

1. Drill an 11/32 in. hole in the exhaust pipe, 127 - 305 mm (5 - 12 in.) from the turbocharger exhaust outlet.

NOTE:

The tapped hole must be in a comparatively straight area of the turbocharger exhaust outlet.

2. Tap the hole to accommodate a 1/8 in. pipe plug. Connect a manometer to the tapped hole.

 **CAUTION:**

To avoid injury before starting and running the engine, ensure the vehicle is parked on a level surface, parking brake is set, and the wheels are blocked.

 **CAUTION:**

To avoid injury from inhaling engine exhaust, always operate the engine in a well-ventilated area. Engine exhaust is toxic.

3. Start and run the engine at idle with a no-load for approximately 5 minutes, allowing the engine coolant to reach normal operating range.
4. Install the vehicle on a chassis dynamometer and run the engine speed to full load.
 - [a] If the exhaust back pressure at full load is less than 10.1 kPa (3.0 in.Hg), check for high inlet air temperature; refer to section 11.9.
 - [b] If the exhaust back pressure at full load is 10.1 kPa (3.0 in.Hg) or greater, refer to section 11.8.1.

11.8.1 Engine Exhaust System Resolution

Perform the following steps to resolve the engine exhaust system:

1. Visually inspect the engine exhaust system; refer to OEM guidelines.
2. Repair or replace defective exhaust system components; refer to OEM guidelines.
3. Verify exhaust system resolution; refer to section 11.8.1.1.

11.8.1.1 Test the Engine with Replaced Exhaust System

Perform the following steps to determine if replaced engine exhaust system components resolved lack of power condition:

1. Start and run the engine.
2. Test drive the vehicle to ensure lack of power has been resolved.
 - [a] If no lack of power occurred during the test drive, no further troubleshooting is required. Shut down the engine.
 - [b] If lack of power occurred during the test drive, shut down the engine. Check for high inlet air temperature; refer to section 11.9.

11.9 HIGH INLET AIR TEMPERATURE

To determine if high inlet air temperature is causing lack of power, perform the following:

1. Test the radiator fan, fan drive, or fan shroud for proper operation or configuration; refer to OEM guidelines.

NOTE:

The engine will be torque limited to protect the turbocharger and charge air cooler; (you will receive derate codes 110 and 404, FMI 14). This is normal engine operation for component protection.

2. Examine test results.
 - [a] If the radiator fan, fan drive, or fan shroud pass OEM test, check high altitude operation; refer to section 11.10.
 - [b] If the radiator fan, drive or shroud did not operate correctly; refer to section 11.9.1.

11.9.1 Radiator Fan, Drive and Shroud Replacement

Perform the following steps to replace the radiator fan, drive and or shroud:

1. Remove and replace the radiator fan, drive and/or shroud; refer to OEM guidelines.
2. Verify replacement; refer to section 11.9.1.1.

11.9.1.1 Test the Engine with Radiator Fan, Fan Drive, or Fan Shroud Replacement

Perform the following steps to determine if replaced radiator fan, fan drive, or fan shroud resolved lack of power condition:

 **CAUTION:**

To avoid injury before starting and running the engine, ensure the vehicle is parked on a level surface, parking brake is set, and the wheels are blocked.

 **CAUTION:**

To avoid injury from inhaling engine exhaust, always operate the engine in a well-ventilated area. Engine exhaust is toxic.

1. Start and run the engine.
2. Test drive the vehicle to ensure lack of power has been resolved.

- [a] If no lack of power occurred during the test drive, no further troubleshooting is required. Shut down the engine.
- [b] If lack of power occurred during the test drive, shut down the engine. Check high altitude operation; refer to section 11.10.

11.10 HIGH ALTITUDE OPERATION

To determine if high altitude operation is causing lack of power:

1. Examine the altitude performance curve, see Figure 11-4.
2. Based on the altitude curve data, , decide if high altitude is causing the lack of power.
 - [a] If your vehicle is operating above sea level, a loss of power will be encountered, no further troubleshooting is required.
 - [b] If your vehicle is operating at or below sea level and there is a lack of power, refer to section 11.11.

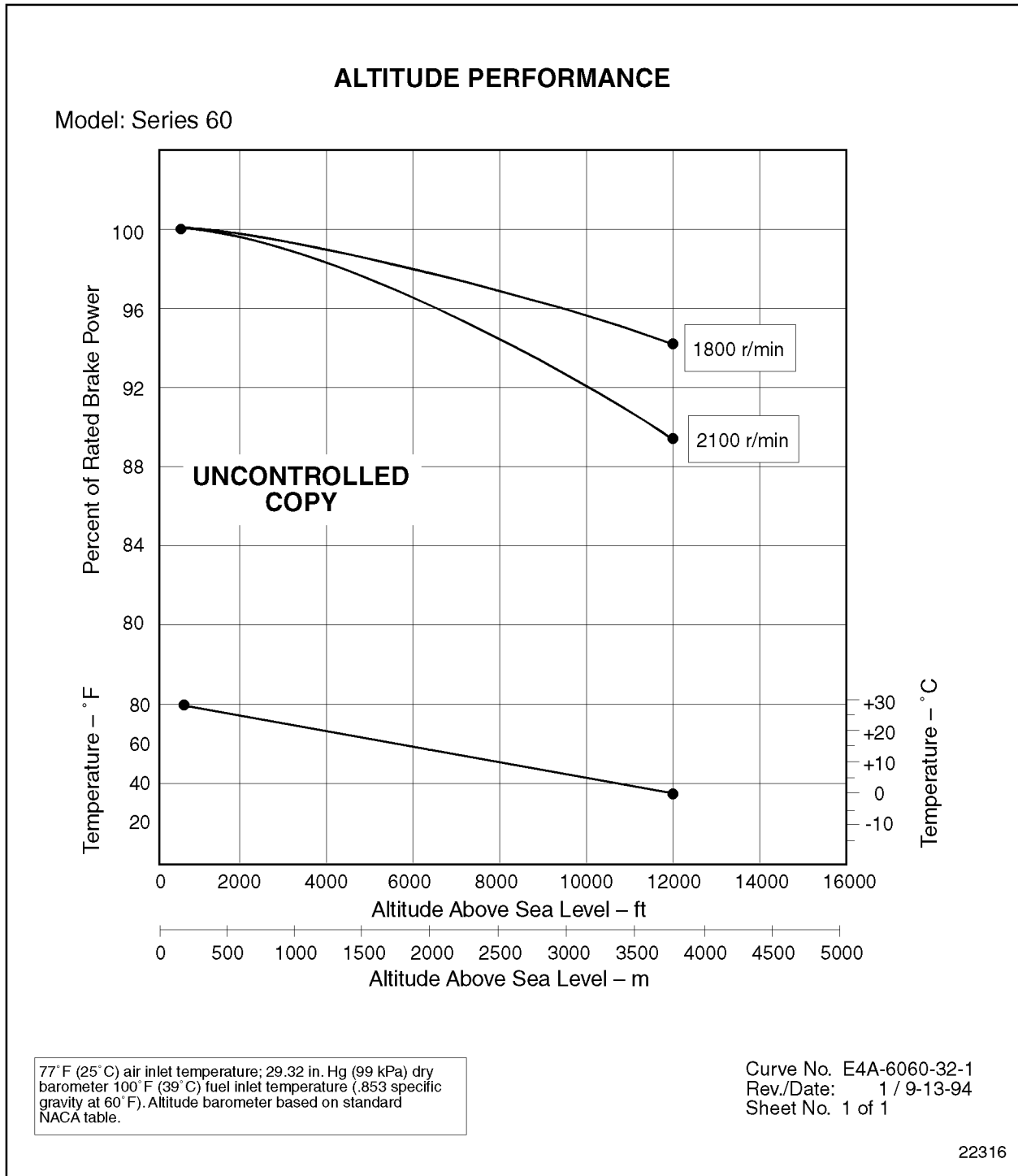

Figure 11-4 Altitude Performance Curve

11.11 INCORRECT CAMSHAFT TIMING

To determine if incorrect camshaft timing is causing lack of power, perform the following steps:

Check the camshaft timing; if the dial indicator reading is within 0.262 - 0.284 in. (6.655 - 7.214 mm), no further troubleshooting is required. If the dial indicator reading is not within 0.262 - 0.284 in. (6.655 - 7.214 mm), check engine timing; refer to section 11.11.1.

NOTE:

The above camshaft timing settings apply to all 12.7L and 14L DDEC V engine models.

11.11.1 Engine Timing Resolution

Perform the following steps to resolve incorrect engine timing:

1. Perform an engine gear train timing check; refer to appropriate service manual, engine chapter.
2. Verify engine timing resolution; refer to section 11.11.1.1.

11.11.1.1 Test Engine with Correct Timing

Perform the following steps to determine if corrected engine timing resolved lack of power condition:

 **CAUTION:**

To avoid injury before starting and running the engine, ensure the vehicle is parked on a level surface, parking brake is set, and the wheels are blocked.

 **CAUTION:**

To avoid injury from inhaling engine exhaust, always operate the engine in a well-ventilated area. Engine exhaust is toxic.

1. Start and run the engine.
2. Test drive the vehicle to ensure lack of power has been resolved.
 - [a] If no lack of power occurred during the test drive, no further troubleshooting is required. Shut down the engine.
 - [b] If lack of power occurred during the test drive, shut down the engine. Call the Detroit Diesel Customer Support Center (313-592-5800).

11.12 VERIFICATION OF POWER WITH CHASSIS DYNAMOMETER

The chassis dynamometer is a device for applying specific loads to a vehicle to determine if the vehicle will perform to published specifications and to permit a physical inspection for leaks of any kind. It is an excellent method for detecting improper tune-up, misfiring injectors, low compression, and other malfunctions.

11.12.1 Chassis Dynamometer Room Ventilation Recommendations

For safe and accurate dynamometer readings, the chassis dynamometer room must be properly ventilated.

 **CAUTION:**

To avoid injury before starting and running the engine, ensure the vehicle is parked on a level surface, parking brake is set, and the wheels are blocked.

 **CAUTION:**

To avoid injury from inhaling engine exhaust, always operate the engine in a well-ventilated area. Engine exhaust is toxic.

If a vehicle is tested on a dynamometer located in an area without proper ventilation, the engine will be subject to high ambient air temperatures. High air inlet temperatures can result in false low power readings on the dynamometer.

To help ensure accurate horsepower readings, the dynamometer room should have a ceiling-mounted fan with a 850 to 1133 m³ /min (30,000 to 40,000 ft³ /min) capacity. This will provide proper ventilation of exhaust gases and heat radiated by the operating engine.

For direct engine cooling, Detroit Diesel recommends the use of a 368 m³ /min (13,000 ft³ /min) or greater capacity barrel-type ram air fan. This should be portable so that it can be conveniently placed three to five feet (approximately one to two meters) in front of the truck and aimed directly at the radiator/charge air cooler package.

11.12.2 Chassis Dynamometer Test and Run-in Procedure

The function of the dynamometer is to absorb and measure the engine output after it has been transmitted through the vehicle transmission and driveline to the drive tires.

The vehicle is connected to dynamometer through the roller absorption unit. The load on the vehicle may be varied from zero to maximum by decreasing or increasing the resistance in the unit. The amount of power absorbed in a water brake type dynamometer, as an example, is governed by the volume of fluid within the working system. The fluid offers resistance to a rotating motion. By controlling the volume of water in the absorption unit, the load may be increased or decreased as required.

The following are some tips to keep in mind in preparing the vehicle before the dynamometer run and during the actual testing:

- Follow all applicable safety procedures from the chassis dynamometer manufacturer.
- Observe the air intake duct and charge air fan shrouding to identify misalignments. Correct as necessary.
- Make sure the differential lock is “on.”
- Make sure the radiator/charge air cooler system fan(s) are locked on.
- If the vehicle is equipped with anti-lock brakes (ABS), disable the ABS controller by unplugging it or removing its power fuse/breaker.
- Instrument the engine for fuel pressure, air inlet restriction, exhaust backpressure, and crankcase pressure, and note these readings during the dynamometer run.
- Make sure the vehicle hood is down and locked into its normal position.
- Make sure the engine is fully warmed up before placing the vehicle on the dynamometer. Both oil and coolant temperature should be at least 180° F (82° C).
- When loading the vehicle on the dynamometer, make sure the vehicle is positioned onto the rollers as straight as possible.
- For direct engine cooling, Detroit Diesel recommends the use of a 368 m³ /min (13,000 ft³ /min) or greater capacity barrel-type ram air fan. This should be portable so that it can be conveniently placed three to five feet (approximately one to two meters) in front of the truck and aimed directly at the charge air cooler. This is especially important at high altitudes.
- During high ambient temperature conditions (90+° F, 32+° C), it may also be necessary to use a water spray mist fan in front of the vehicle to prevent overheating.
- Running the dynamometer in “manual” mode instead of “automatic” mode allows for maximum control of the test process and may result in more consistent test results.
- During the horsepower test, make sure “percent engine load” and “torque limiting factor” are 100% by monitoring them with a computer equipped with DDDL.
- Select a transmission gear with a 1:1 gear ratio during the horsepower test.
- Take horsepower reading at 1500 rpm and 1750 rpm. Stabilize at rated speed for at least one minute before taking a final horsepower reading. Compare the recorded horsepower to the appropriate minimum horsepower tables below for particular ratings.

- Note that the following charts are for vehicles with manual transmissions. Vehicles with automatic transmissions (i.e. equipped with torque converters) will have slightly lower minimum horsepower values than listed in Table 11-4 and Table 11-5

Engine Model 6067MV_E 12L		
Engine HP Rating (Peak Torque)	Minimum Acceptable Wheel HP @	
	1500 rpm	1750 rpm
380 bhp @ 1800 (1350 lb-ft)	295	295
390 bhp @ 1800 (1350 lb-ft)	300	303
425 bhp @ 1800 (1450 lb-ft)	322	330
435 bhp @ 1800 (1450 lb-ft)	322	338
445 bhp @ 1800 (1450 lb-ft)	322	345
445 bhp @ 1800 (1550 lb-ft)	342	345
450 bhp @ 1800 (1550 lb-ft)	342	349
455 bhp @ 1800 (1550 lb-ft)	345	353

Table 11-4 Minimum Acceptable Wheel HP 12L

Engine Model 6067HV_E 14L		
Engine HP Rating (Peak Torque)	Minimum Acceptable Wheel HP @	
	1500 rpm	1750 rpm
515 bhp @ 1800 (1450 lb-ft)	320	392
455 bhp @ 1800 (1550 lb-ft)	344	353
490 bhp @ 1800 (1550 lb-ft)	344	380
515 bhp @ 1800 (1550 lb-ft)	344	400
470 bhp @ 1800 (1650 lb-ft)	365	365
490 bhp @ 1800 (1650 lb-ft)	366	380
515 bhp @ 1800 (1650 lb-ft)	366	400

Table 11-5 Minimum Acceptable Wheel HP 14L