

SH NO.	TITLE
1)	INDEX
2)	HARNES ARCHITECTURE
3)	LOCATION OF MAJOR COMPONENTS
4)	LOCATION OF MAJOR COMPONENTS
5)	SYMBOLS INDEX
6)	SYMBOLS INDEX (CONTINUED)
7)	SYMBOLS INDEX (CONTINUED)
8)	SYMBOLS INDEX (CONTINUED)
9)	CHARGE AND START
10)	POWER DISTRIBUTION - UNSWITCHED CIRCUITS
11)	POWER DISTRIBUTION - IGNITION SWITCHED CIRCUITS
12)	POWER DISTRIBUTION - ACCESSORY SWITCHED CIRCUITS
13)	POWER DISTRIBUTION - CIRCUIT BREAKER - ENGINE
14)	TURN SIGNALS / HAZARD LIGHTS
15)	STOP LAMPS
16)	MARKER / CLEARANCE LAMPS / LEFT POLE / RIGHT POLE
17)	HEADLAMPS
18)	BACK - UP LIGHT SWITCH
19)	DAYCAB AD / LOADLIGHTS
20)	SLEEPER AD / LOADLIGHTS - 48" / 63" HIGH ROOF
21)	FOG LIGHTS
22)	CAB DOOR LOCKS
23)	REMOTE KEYLESS ENTRY RELAY - OPTIONAL
24)	CAB DOME LIGHT / DOOR LAMPS / DOOR JAMB / ALARM
25)	CAB FOOTLIGHTS / CIGAR LIGHTER / POWER POINT / B - PANEL POWER POINT
26)	48" / 63" HIGH ROOF SLEEPER LIGHTS / DOOR LOCK / DOOR JAMB
27)	48" / 63" HIGH ROOF SLEEPER POWER ACCESS OUTLETS
28)	48" / 63" LOW ROOF SLEEPER
29)	70" SLEEPER
30)	38" SLEEPER
31)	LH DOOR ELECTRIC WINDOW LIFT
32)	RH DOOR ELECTRIC WINDOW LIFT
33)	MIRRORS - STANDARD / MOTORIZED / HEATED AND MIRROR CONTROL
34)	CB RADIO
35)	DASH RADIO
36)	CAB ROOF SPEAKERS - CONCERT CLASS / CONCERT CLASS PREMIUM
37)	CAB ROOF SPEAKERS - CONCERT CLASS EHD
38)	RADIO - 48" / 63" / 70" SLEEPER
39)	CLOCK
40)	WIPER / WASHER
41)	ELECTRIC HORN
42)	CAB HVAC
43)	SLEEPER HVAC - ALL SLEEPERS
44)	SLEEPER LOAD CENTER
45)	SLEEPER POWER SUPPLY HARNESS
46)	NAMUX
47)	BACK - LIGHTING (+12 VOLTS) AND PANEL LAMPS DIMMER
48)	BACK - LIGHTING NEGATIVE LINKS (GROUND)
49)	OUTSIDE AIR TEMPERATURE
50)	FIFTH WHEEL / DIFF LOCK / SUSPENSION DUMP VALVE / SPARE ROCKER SWITCHES
51)	FUEL LEVEL
52)	FUEL FILTER - ACCESSORY POWER
53)	PARK BRAKE
54)	FORWARD AND REAR DRIVER AXLE TEMP
55)	VORAD
56)	AIR DRYER
57)	FUEL FILTER RESTRICTION
58)	TIRE PRESSURE CONTROL SYSTEM (TPCS) CAB & CHASSIS
59)	AUX TRANSMISSION OIL TEMP
60)	EATON ULTRASHIFT TRANSMISSION
61)	EATON AUTOSHIFT TRANSMISSION
62)	EATON AUTOSHIFT AND ULTRASHIFT TRANSMISSION (CONTINUED)
63)	MERITOR FREEDOMLINE TRANSMISSION
64)	WTEC TRANSMISSION (ALLISON)
65)	WTEC TRANSMISSION (ALLISON) (CONTINUED)
66)	EATON LIGHTNING TRANSMISSION POWER
67)	MAIN CAB ABS CONNECTIONS
68)	BENDIX ABS SYSTEM
69)	BENDIX ABS SYSTEM (CONTINUED)
70)	BENDIX ABS (CHASSIS)
71)	WABCO ABS SYSTEM (E-BASIC)
72)	WABCO ABS SYSTEM (E-UNIVERSAL)
73)	TRAILER ABS
74)	MAIN CAB ENGINE FIREWALL BULKHEAD
75)	ENGINE - CAT C11 / C13 AND C15
76)	ENGINE - CAT C11 / C13 AND C15 (CONTINUED)
77)	ENGINE - CUM ISM
78)	ENGINE - CUM ISC / ISL
79)	ENGINE - CUM ISX
80)	ENGINE - CUM ISM (BJ SERVICES)
81)	ENGINE - CUM ISM (BJ SERVICES) (CONTINUED)
82)	ENGINE - CUM ISM (BJ SERVICES)
83)	ENGINE - CUM ISM (BJ SERVICES) (CONTINUED)
84)	ENGINE - CUM ISX (BJ SERVICES)
85)	ENGINE - CUM ISX (BJ SERVICES) (CONTINUED)
86)	ENGINE ECU POWER
87)	CHASSIS SPARE GROUNDS
88)	MAIN CAB SPARE RELAY
89)	CHASSIS SENSOR ADD-ON - TRANSFER CASE OIL TEMP / BRAKESAVER OIL TEMP / GENERAL OIL TEMP / AUX XSMN OIL TEMP #3 / PTO OIL TEMP
90)	CUMMINS ICON2 IDLE CONTROL
91)	J1939 ARCHITECTURE
92)	TELEMATICS
93)	SLEEPER LVD / LVD ADAPTER
94)	CUMMINS DUAL STATION CONTROLS (BJ SERVICES)
95)	ENGINE BRAKE CONTROLS
96)	ENGINE FAN CONTROLS
97)	LIFT AXLE CONTROL (W/O AUTO-REVERSE)
98)	LIFT AXLE CONTROL (W/ AUTO-REVERSE)

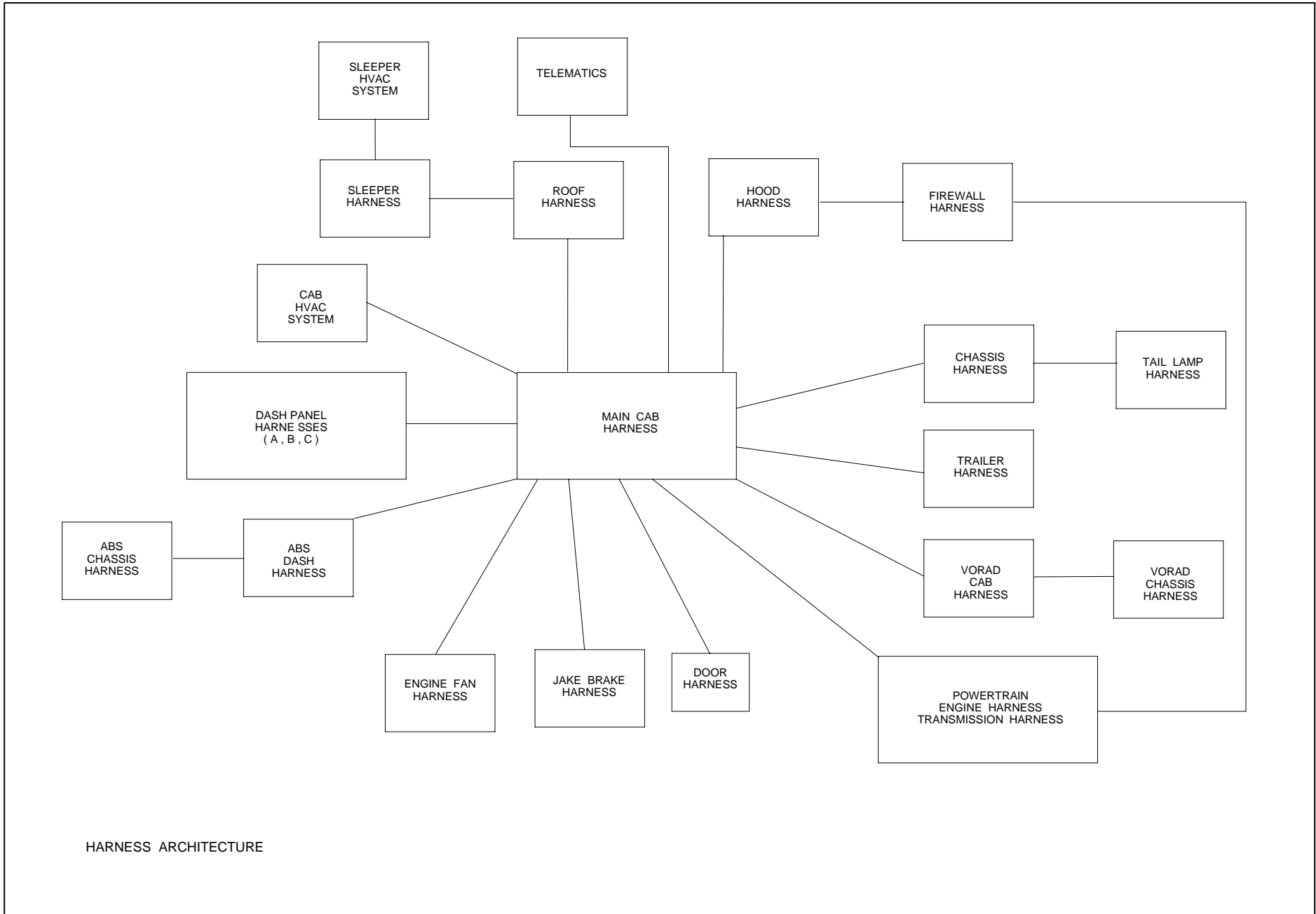

LOCATIONS OF MAJOR ELECTRICAL MODULES IN 379E CAB AND SLEEPER

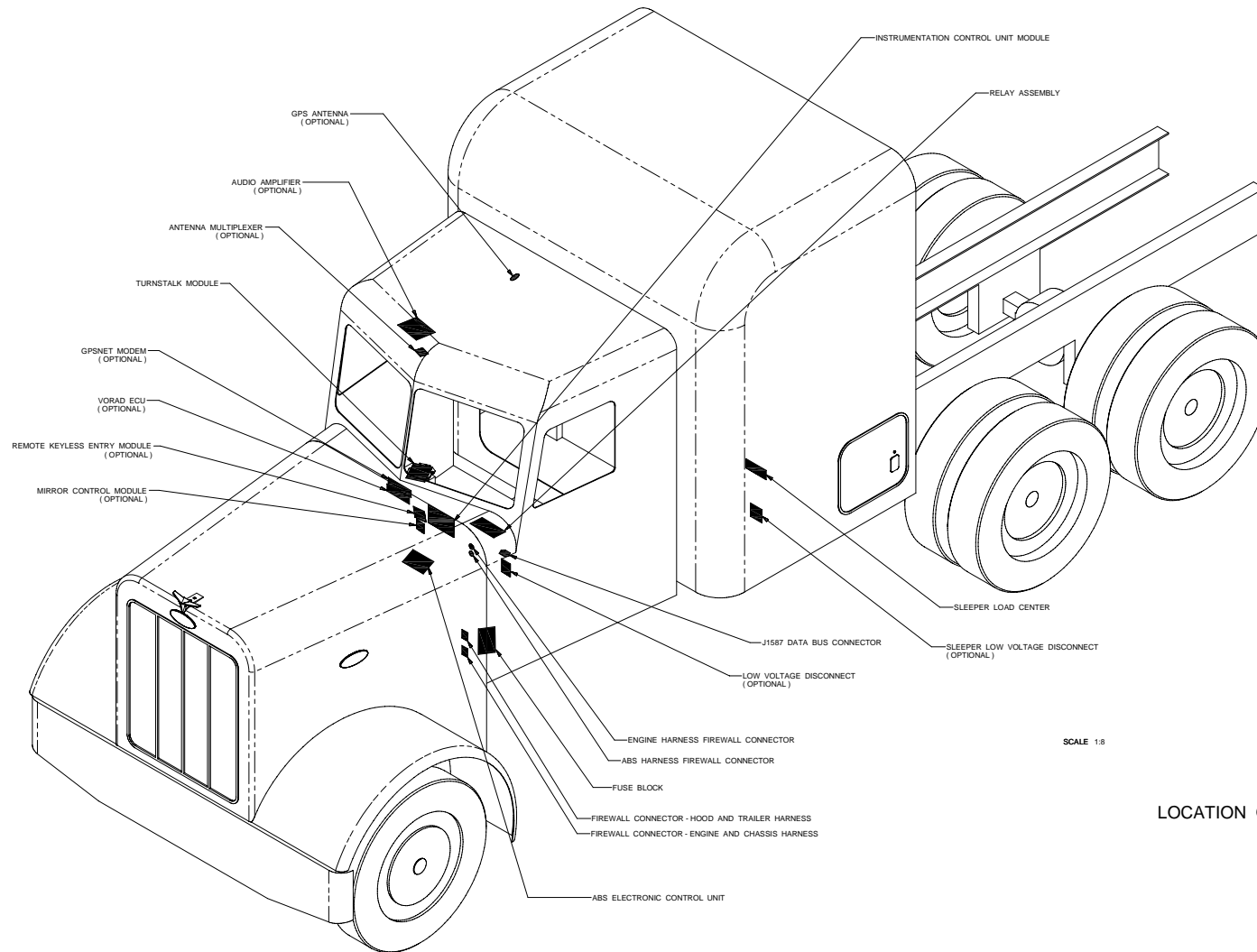





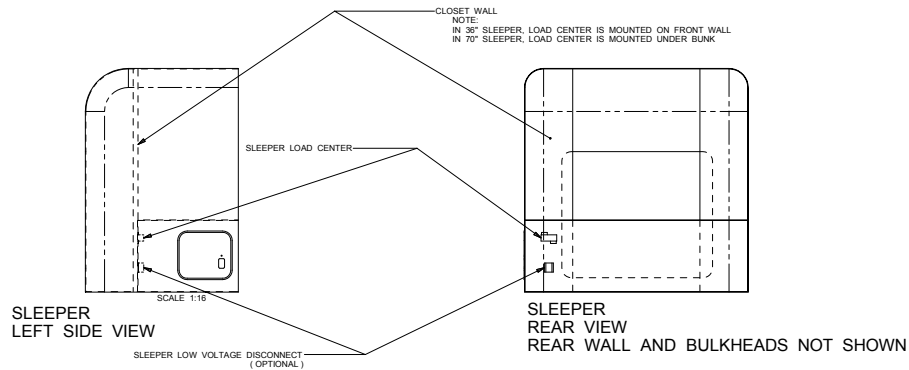
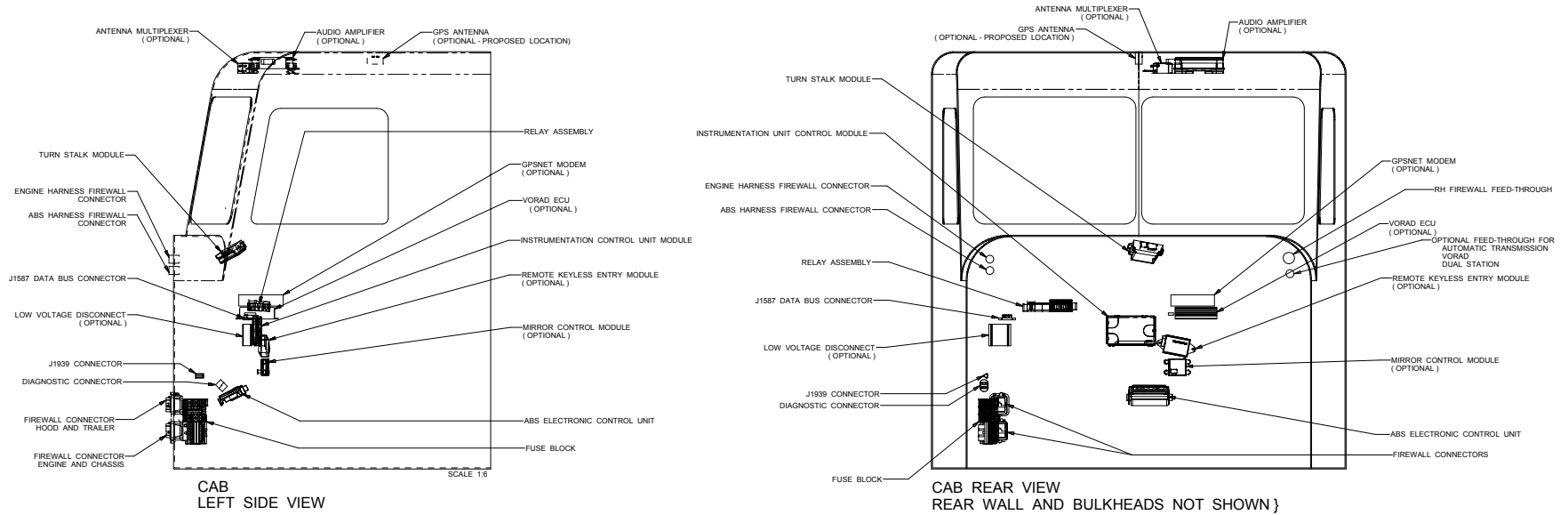



LOCATION OF MAJOR COMPONENTS

LOCATIONS OF ELECTRICAL MODULES IN 379E CAB AND SLEEPER





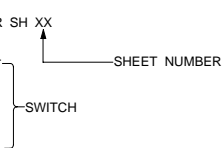
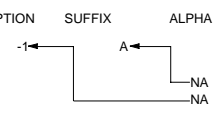

LOCATION OF MAJOR COMPONENTS

SYMBOL / ABBREVIATION KEY

- 1) ⊗ STUD
- 2) • SPLICE
- 3) ○ RING TERMINAL CONNECTORS
- 4) NUMBERS EX CIRCUIT DESCRIPTION SUFFIX ALPHA
- 5)  286 BUSS BAR
- 6) CB CIRCUIT BREAKER
- 7) CLC CHASSIS LOAD CENTER
- 8) SLPR SLEEPER
- 9) TRLR TRAILER
- 10) MFTS MULTI-FUNCTION TURN STALK
- 11) ⊗ CONTINUED TO OTHER SH XX
- 12) ▲ MOMENTARY CONTACT SWITCH
- CONTACT
- 13)  BULB
- 14)  GROUND
- 15)  DIODE
- 16)  RESISTOR
- 17)  CAPACITOR
- 18)  POLYFUSE
- 19)  LIGHT-EMITTING DIODE

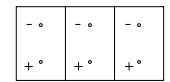
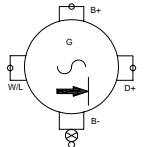

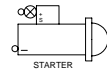
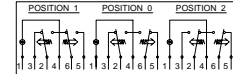
- 20)  STARTER THERMAL OVERLOAD SWITCH
- 21)  NEUTRAL START SWITCH
- 22)  BATTERIES BATTERY
- 23)  ALTERNATOR
- 24)  CIRCUIT BREAKER
- 25)  STARTER
- 26)  WINDOW SWITCH

SYMBOLS INDEX

27)  J1939 CABLE SHIELD

28)  TWISTED PAIR

29)  PRESSURE SWITCH

30)  LAMP

31)  LIGHT



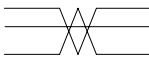

32)  IGNITION SWITCH

33)  WINDOW LIFT MOTOR

34)  TWISTED TRIPLET

SYMBOLS INDEX (CONTINUED)

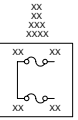
FUSES

- 1)  25 A FUSE
- 2)  XX AMP
- 3)  F1,0 AMP XX
- 4)  XX AMP
- 5)  FUSE 10 AMP
- 6)  XX AMP

ROCKER SWITCH ICONS

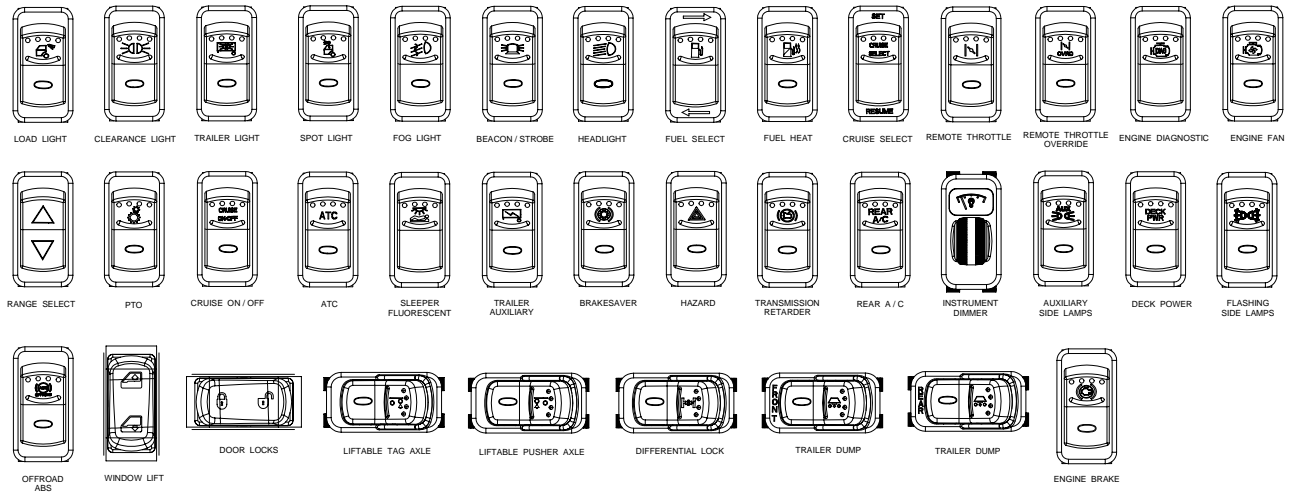

SYMBOLS INDEX (CONTINUED)

RELAYS

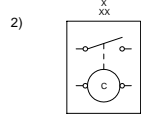
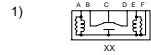

INTAKE AIR HEATER RELAY

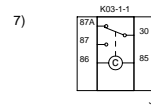
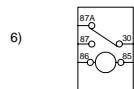
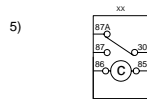
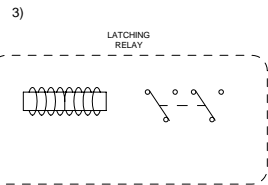

STARTER RELAY

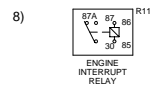

ENGINE INTERRUPT RELAY

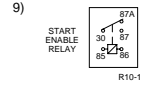

START ENABLE RELAY

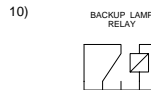

BACK-UP LAMP RELAY

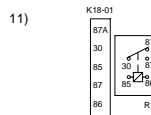

RELAY

SYMBOLS INDEX (CONTINUED)

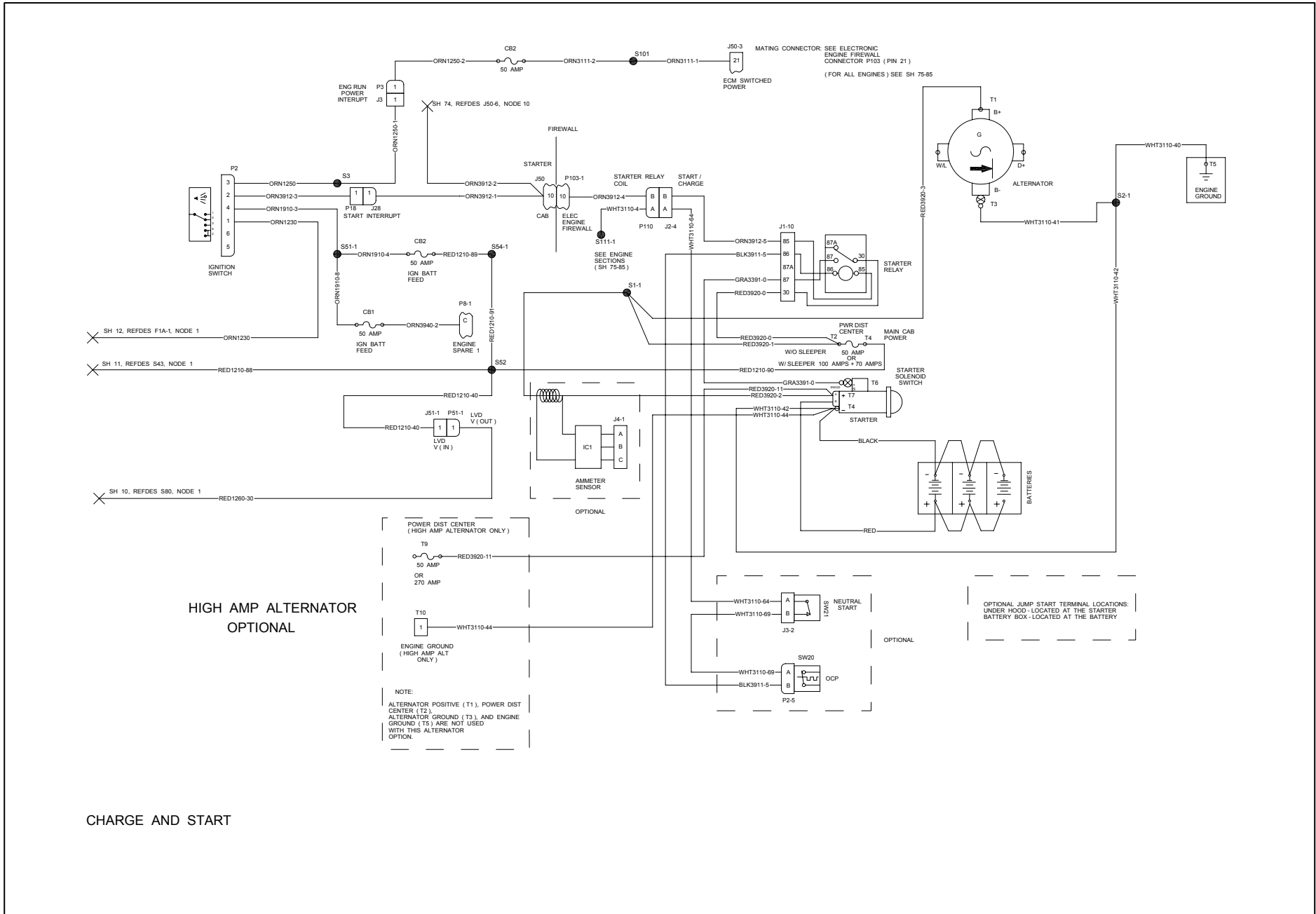

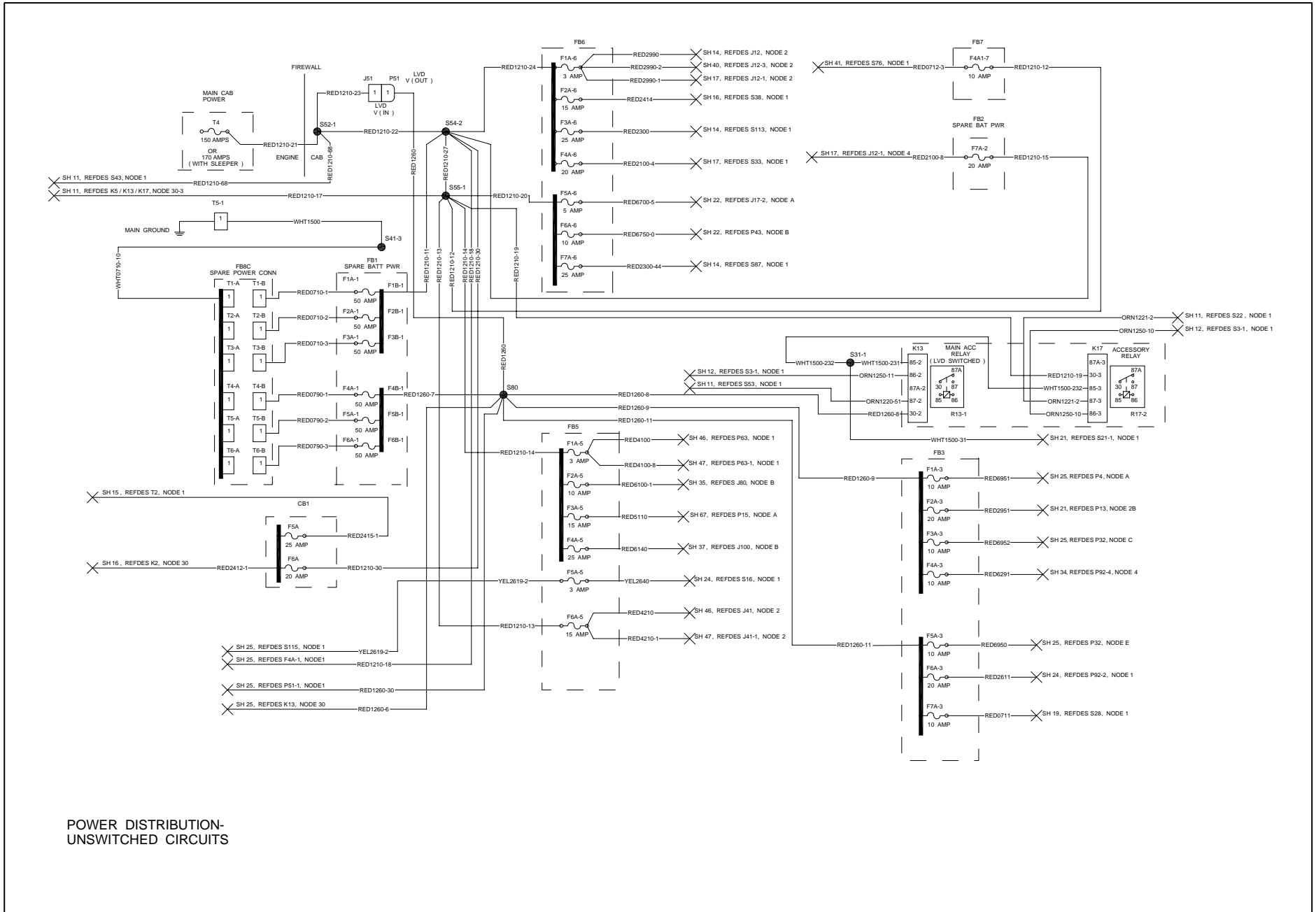

POWER DISTRIBUTION-
UNSWITCHED CIRCUITS

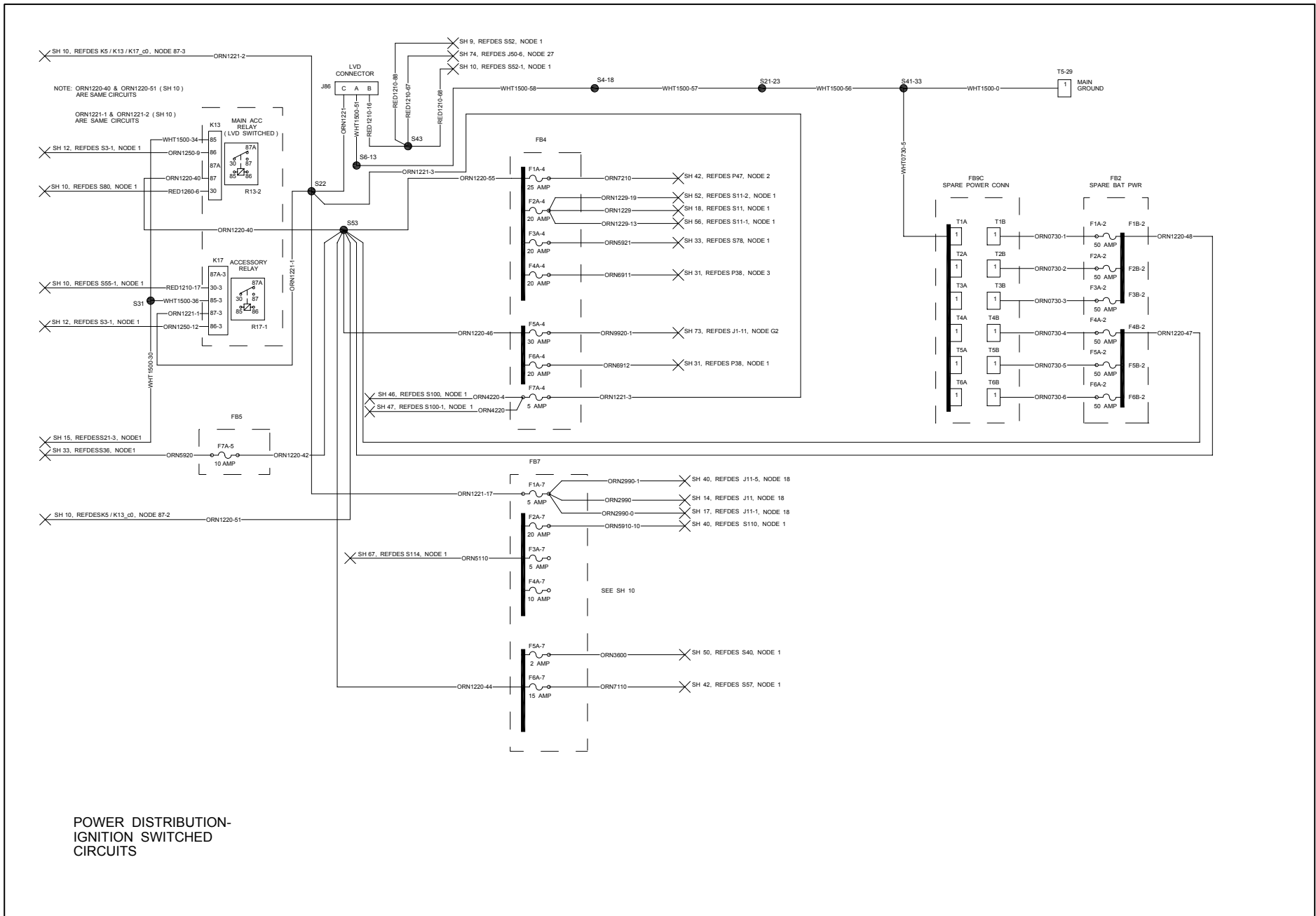

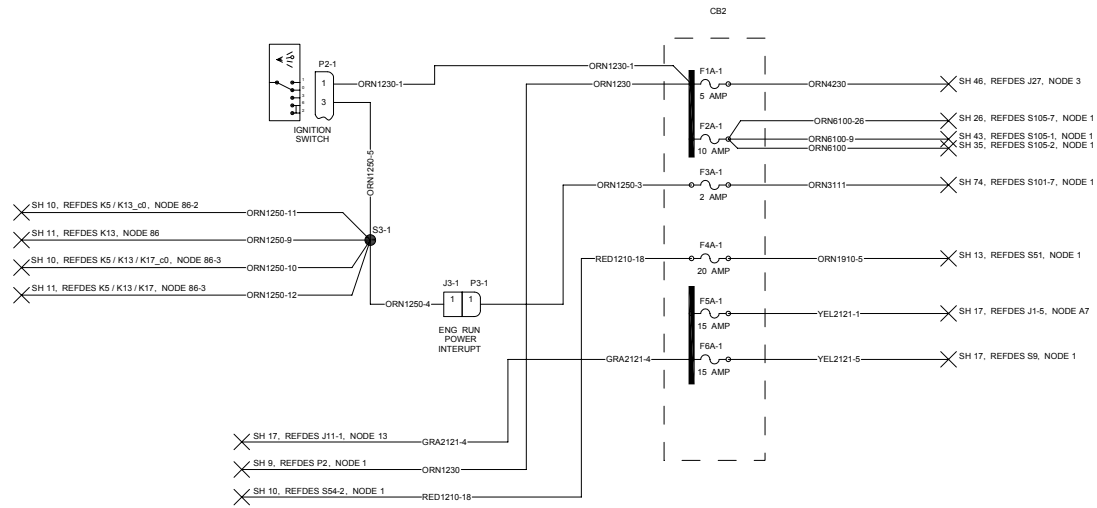

POWER DISTRIBUTION-
ACCESSORY SWITCHED CIRCUITS

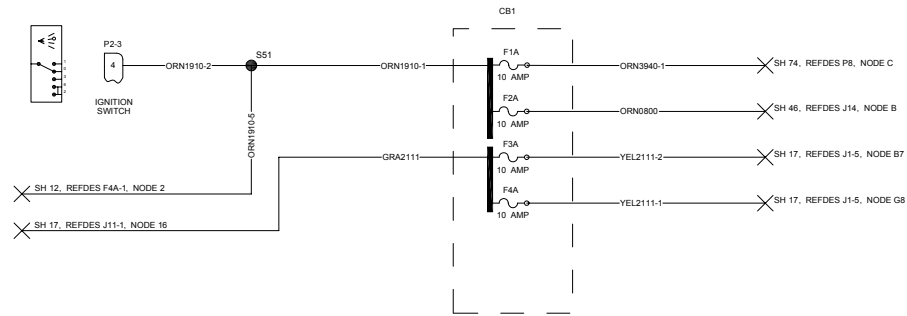

POWER DISTRIBUTION-
CIRCUIT BREAKER-ENGINE / LOW BEAM FEED

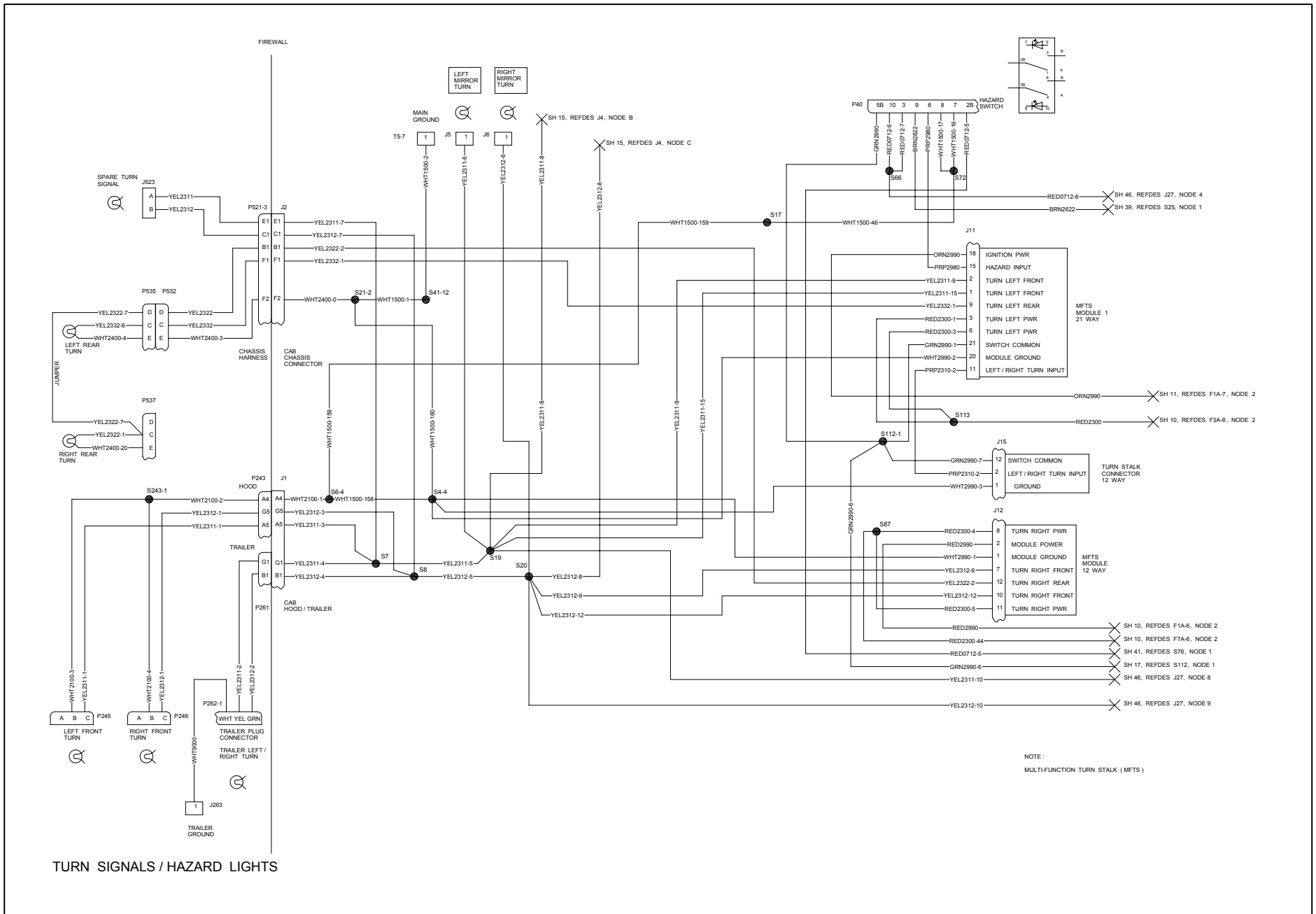

TURN SIGNALS / HAZARD LIGHTS



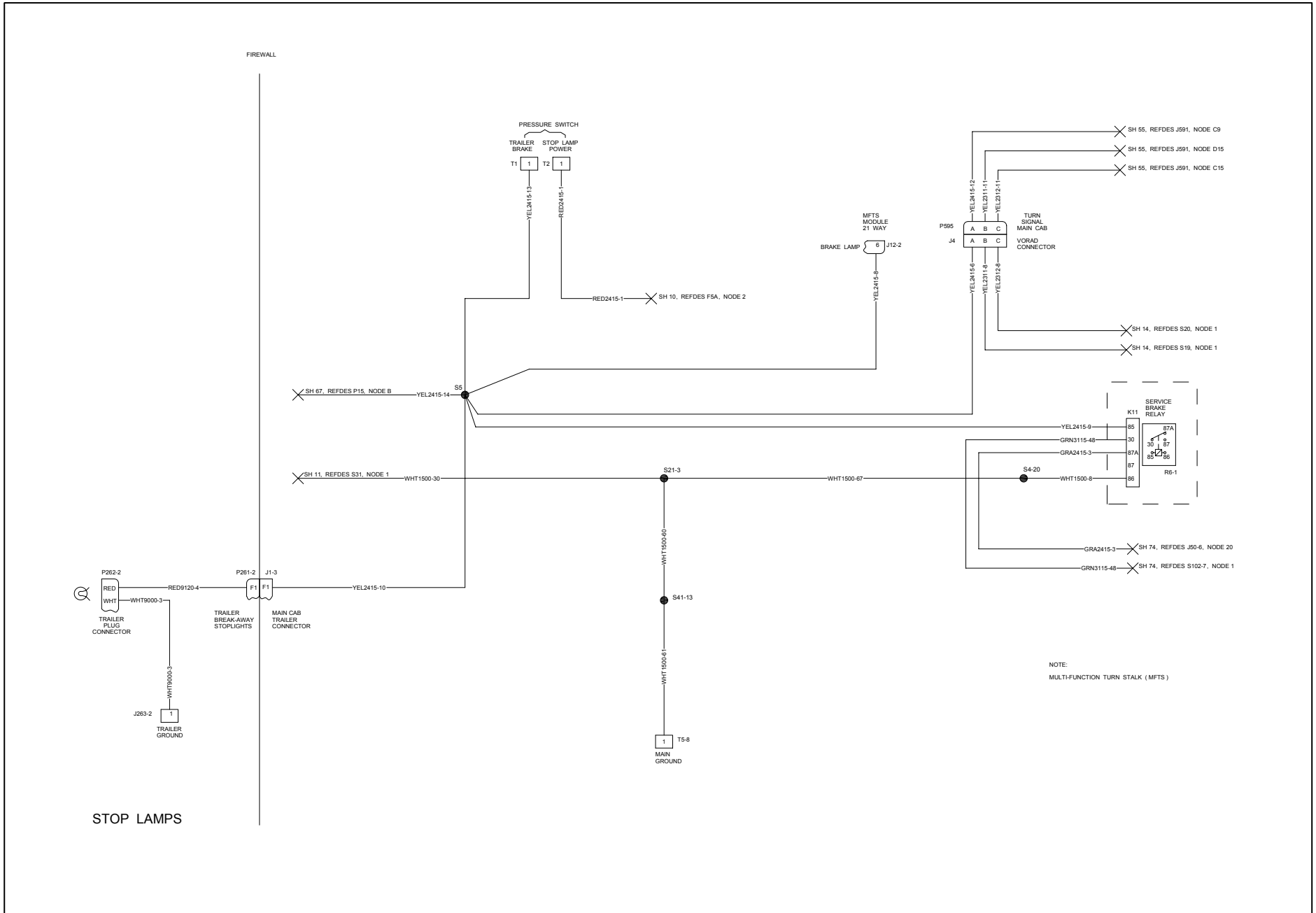

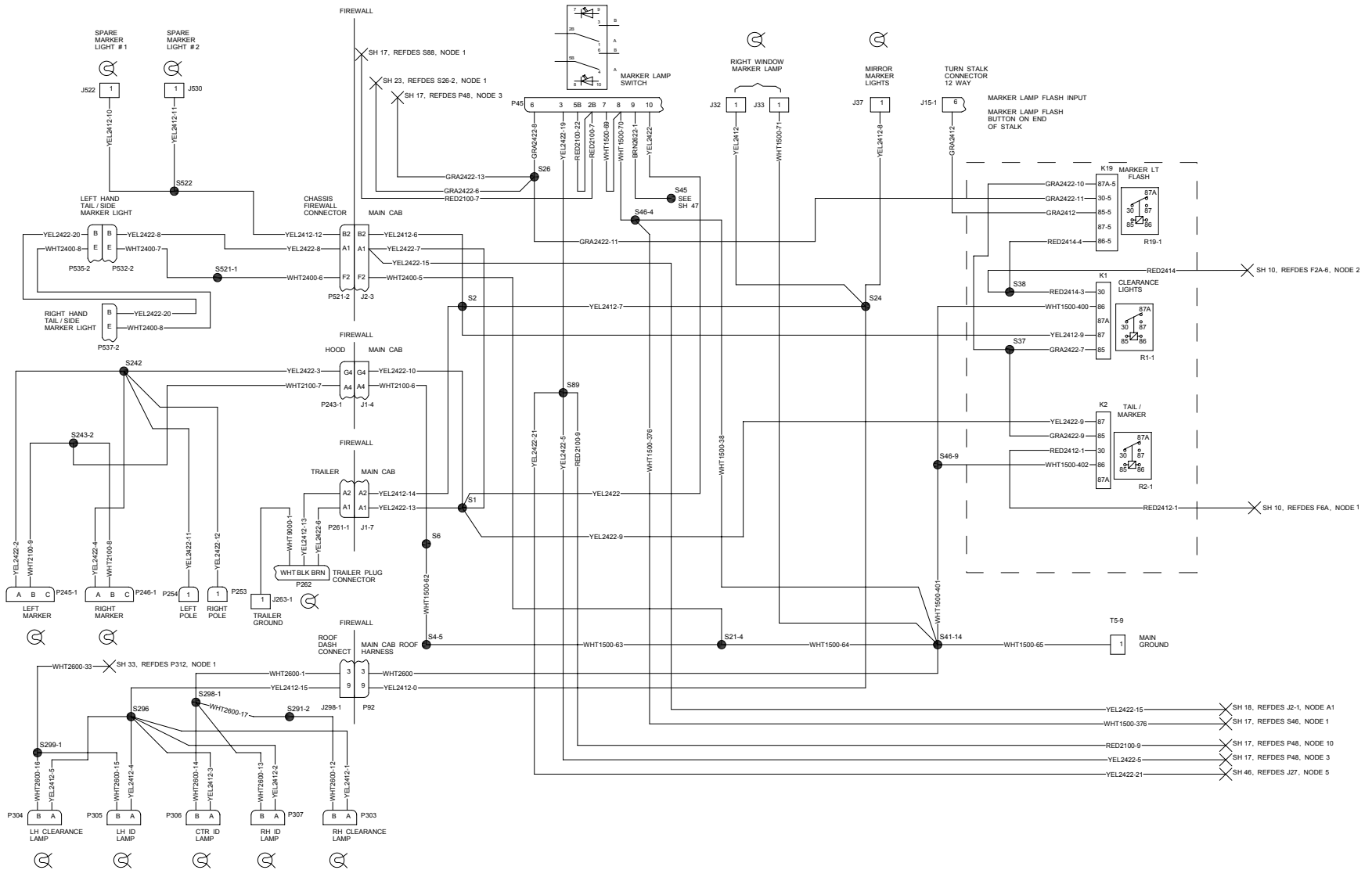

MARKER / CLEARANCE LAMPS / LEFT POLE / RIGHT POLE



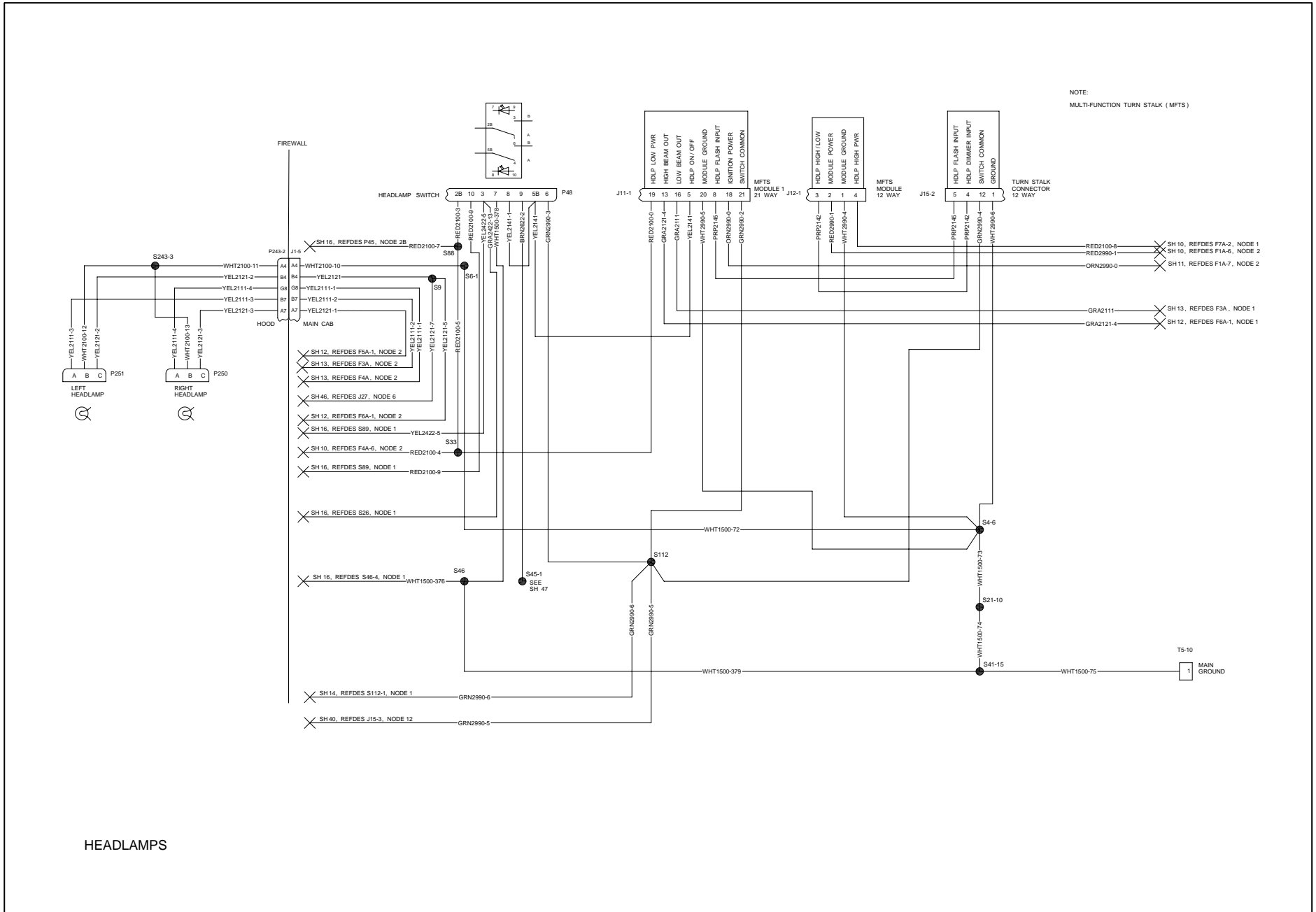

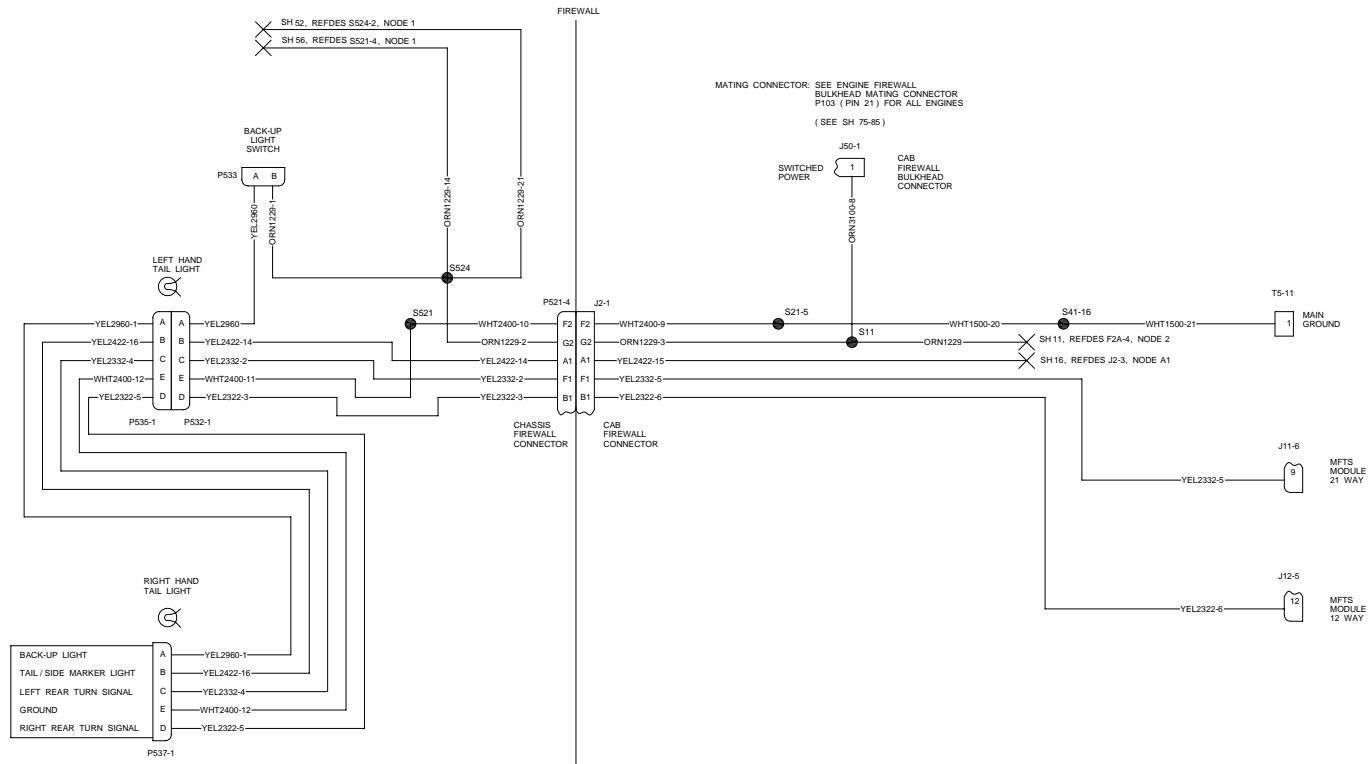

BACK-UP LIGHT SWITCH

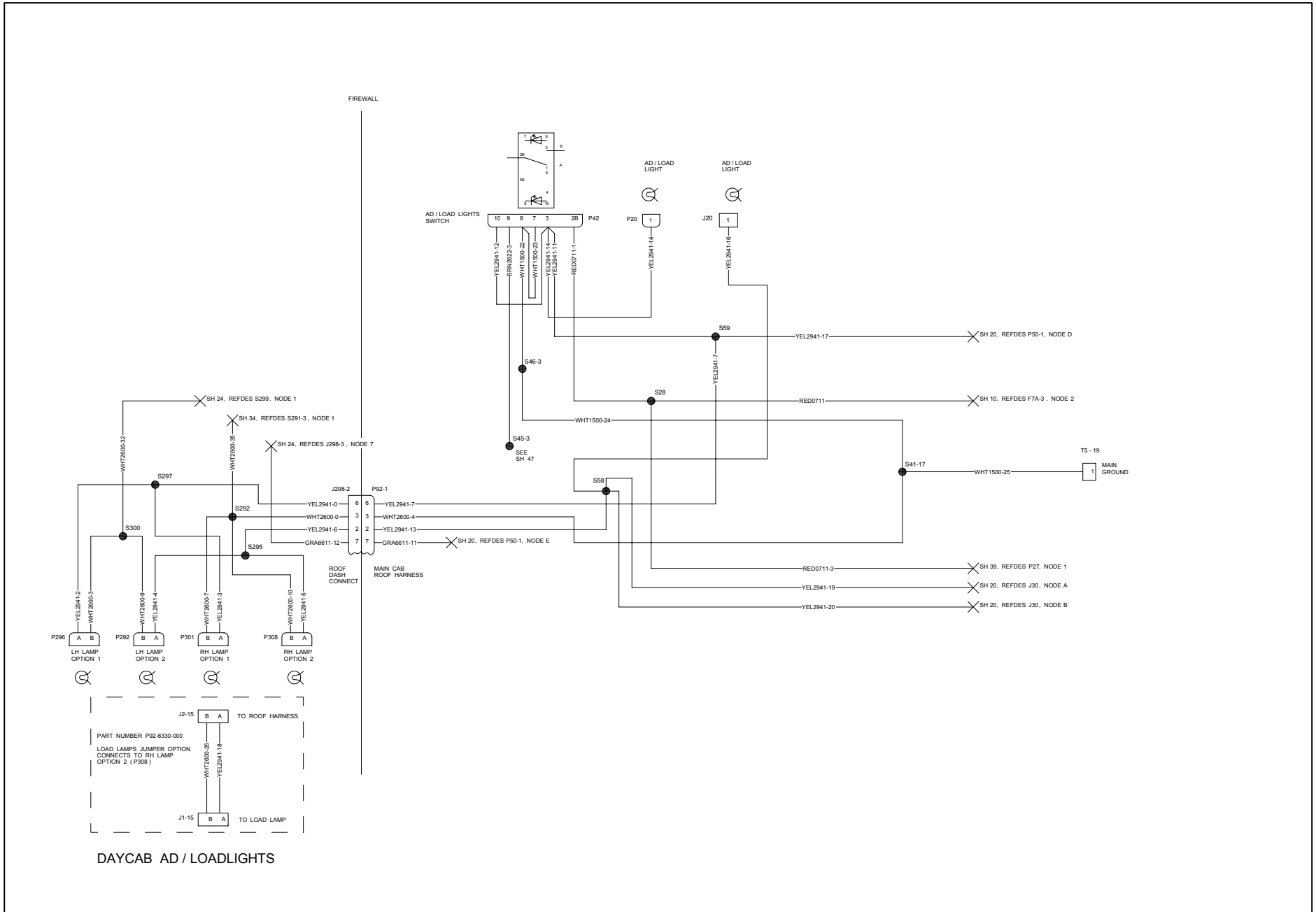

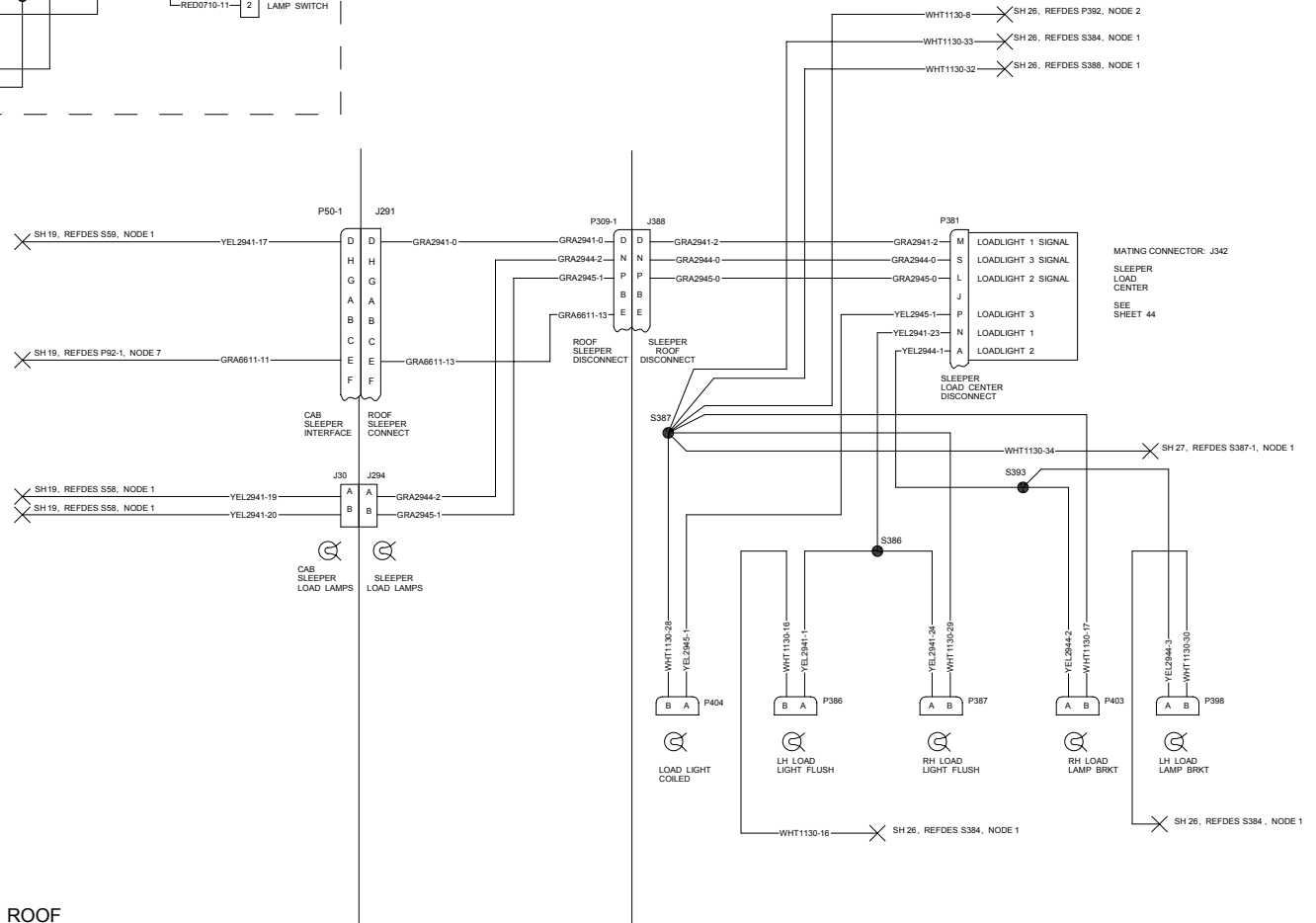
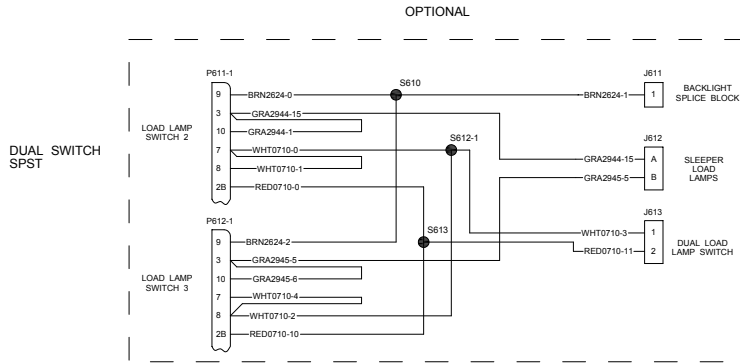

SLEEPER AD / LOADLIGHTS - 48" / 63" HIGH ROOF

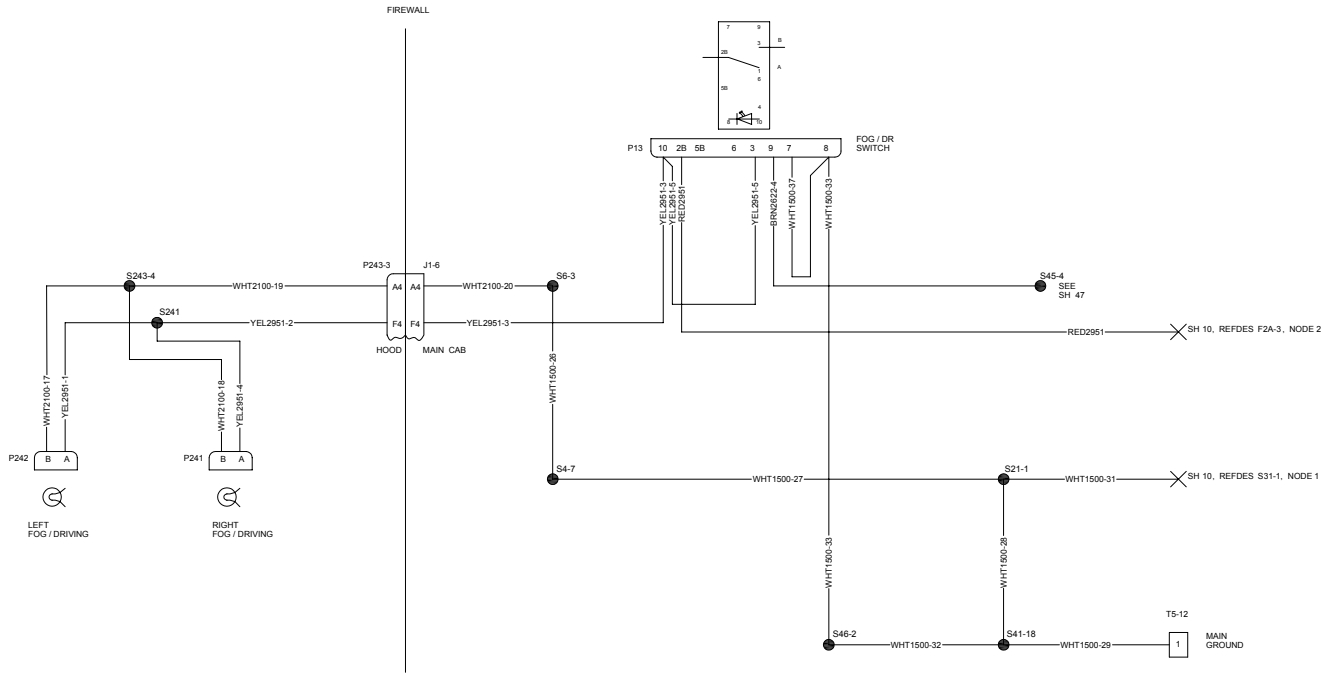

FOG LIGHTS



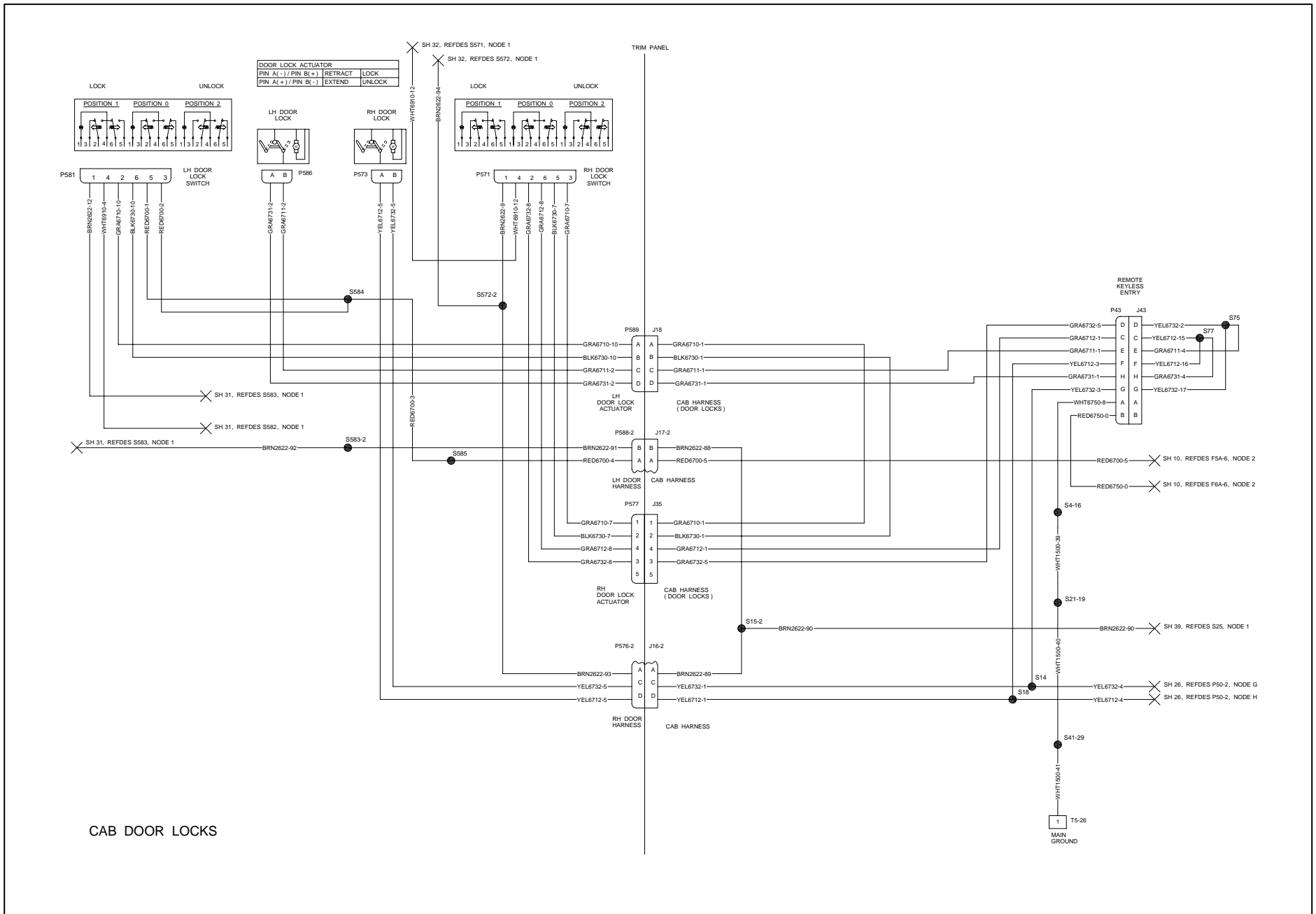

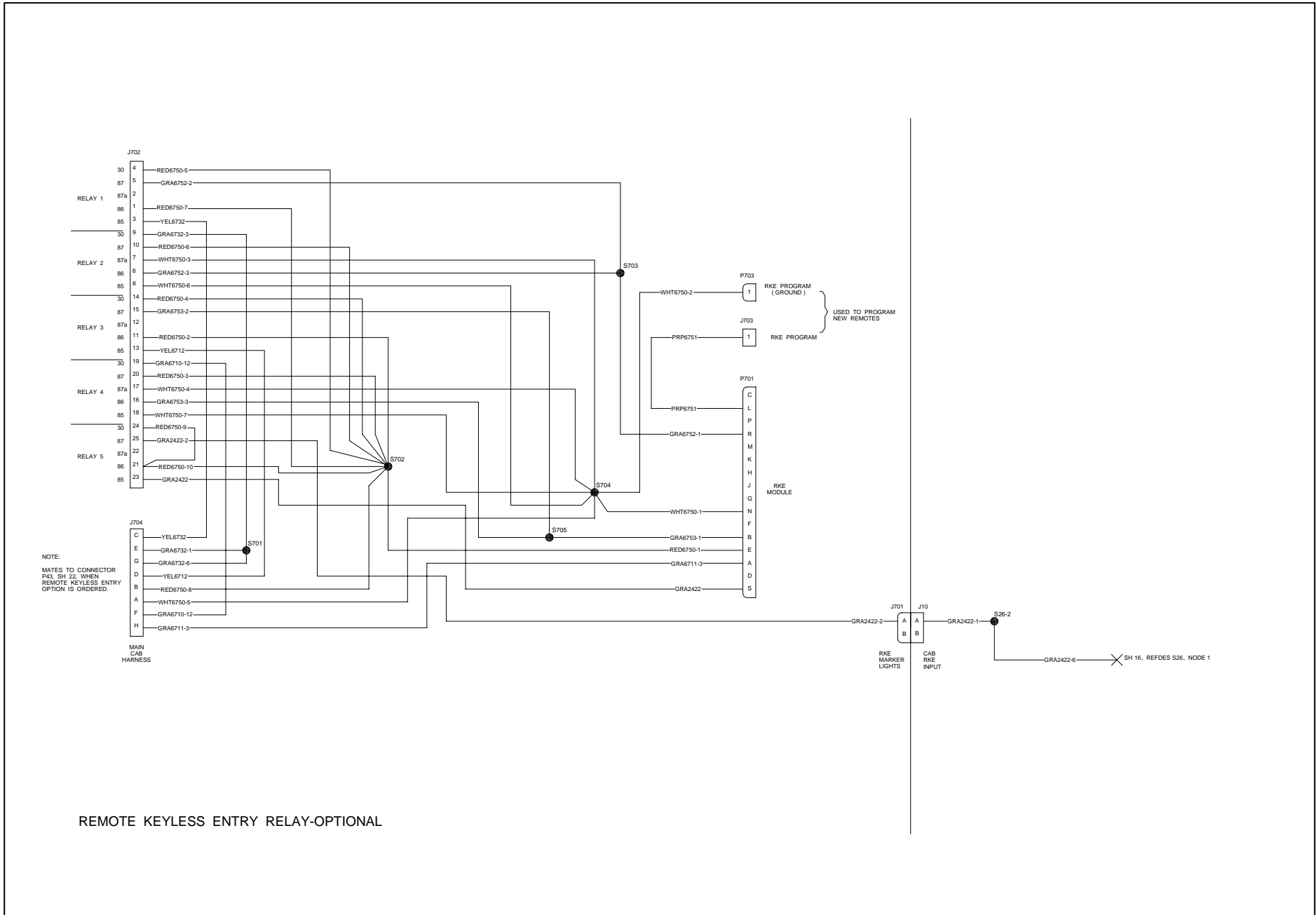

REMOTE KEYLESS ENTRY RELAY-OPTIONAL

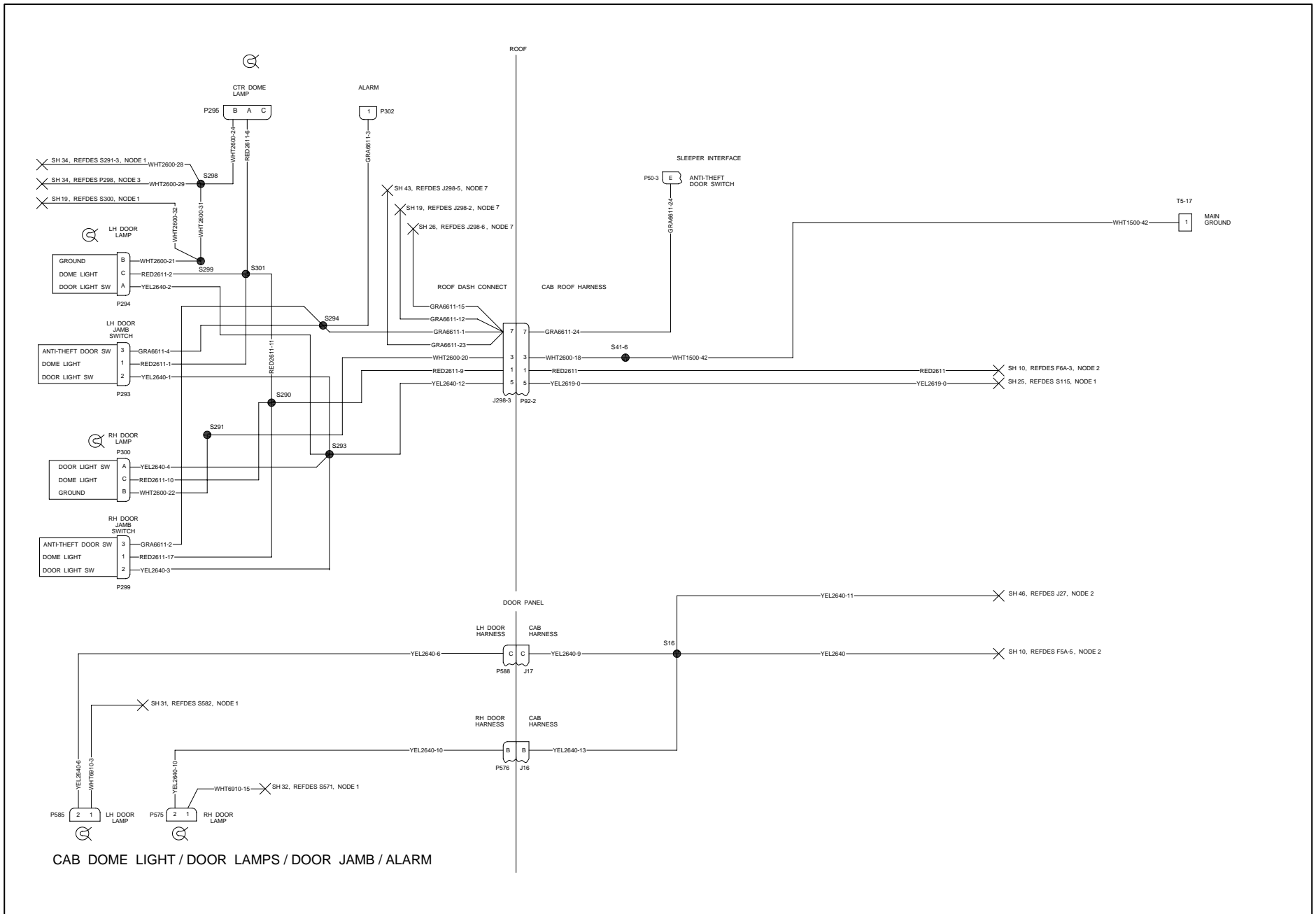

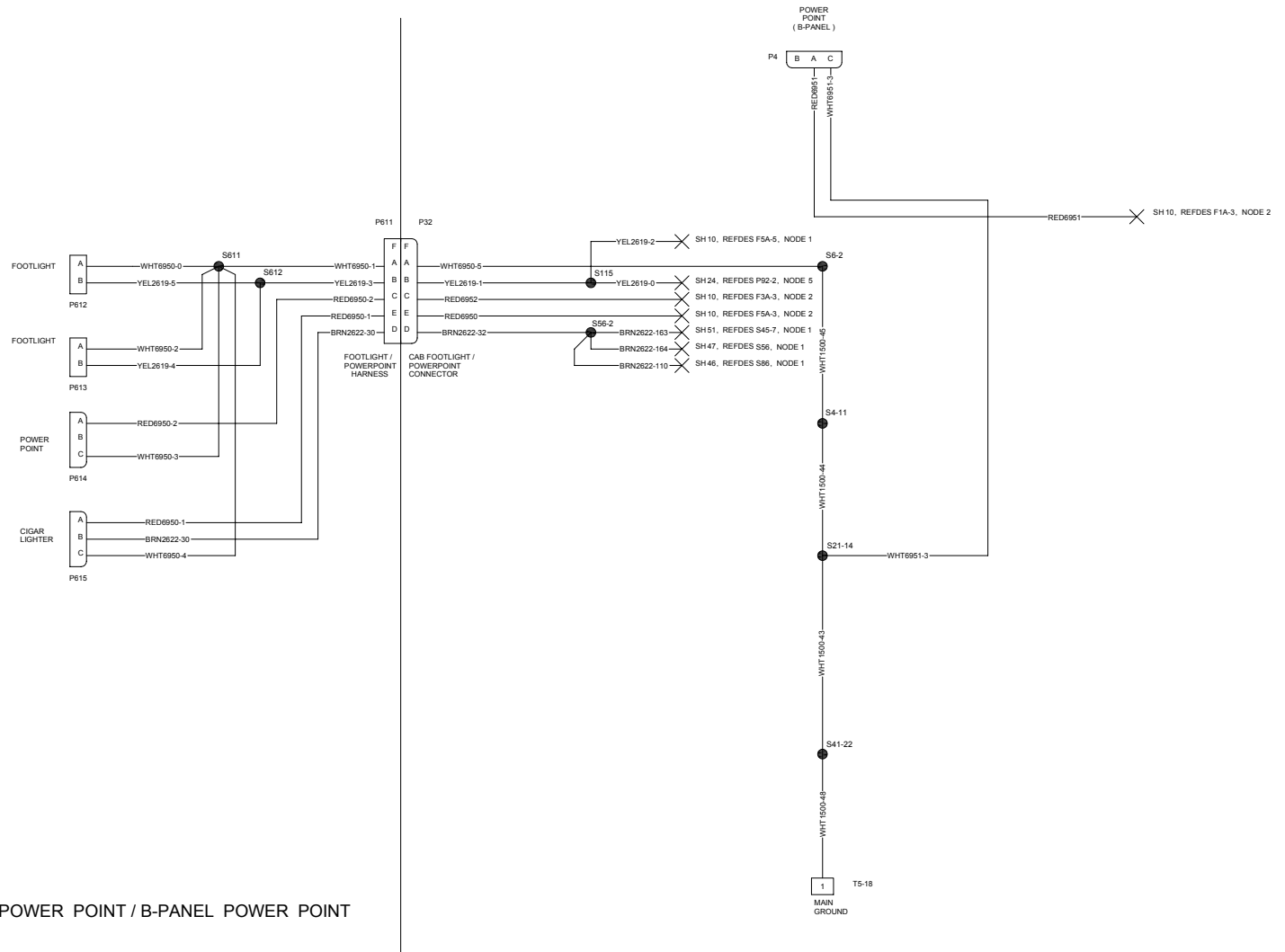

CAB FOOTLIGHTS / CIGAR LIGHTER / POWER POINT / B-PANEL POWER POINT

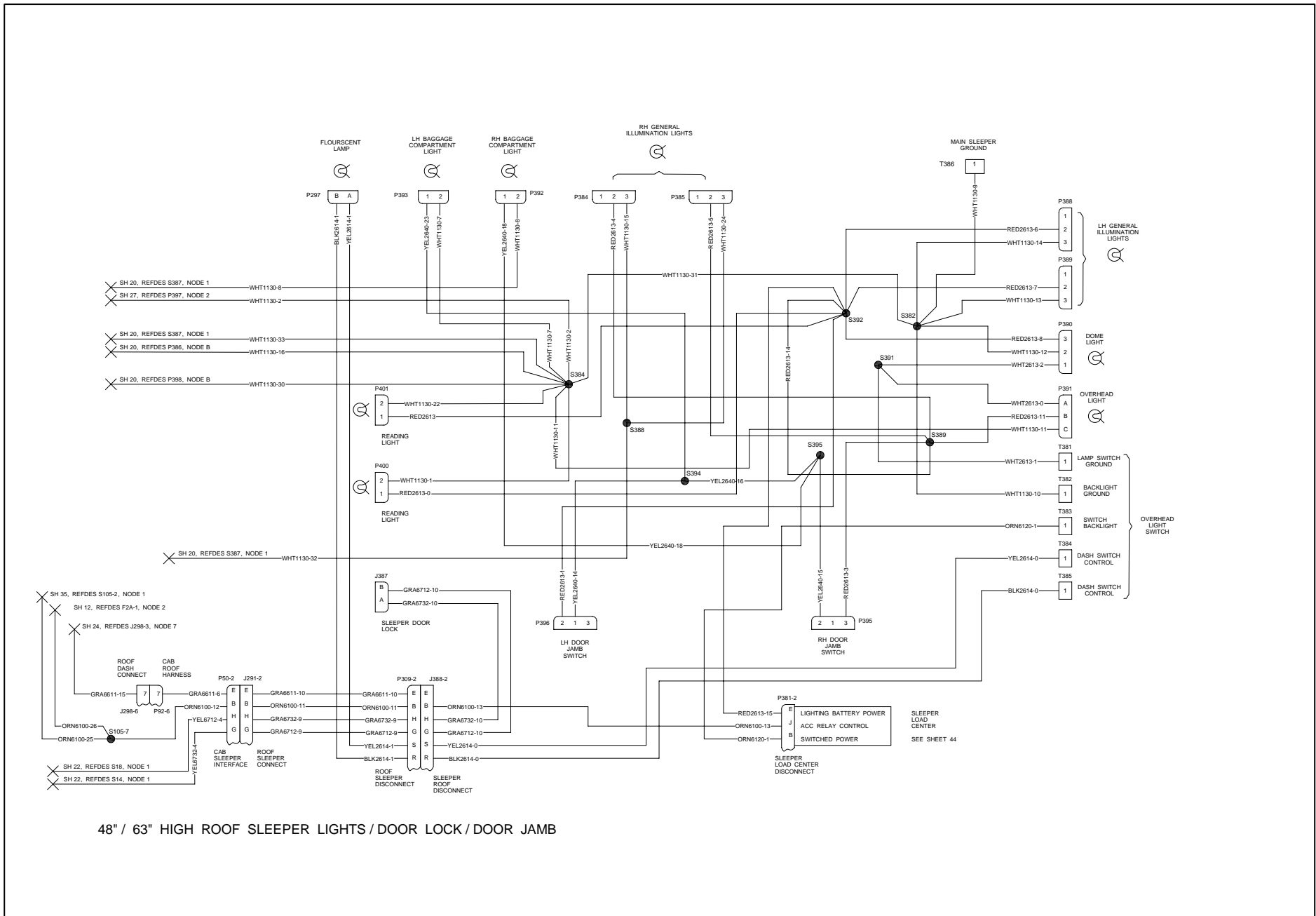

48" / 63" HIGH ROOF SLEEPER LIGHTS / DOOR LOCK / DOOR JAMB

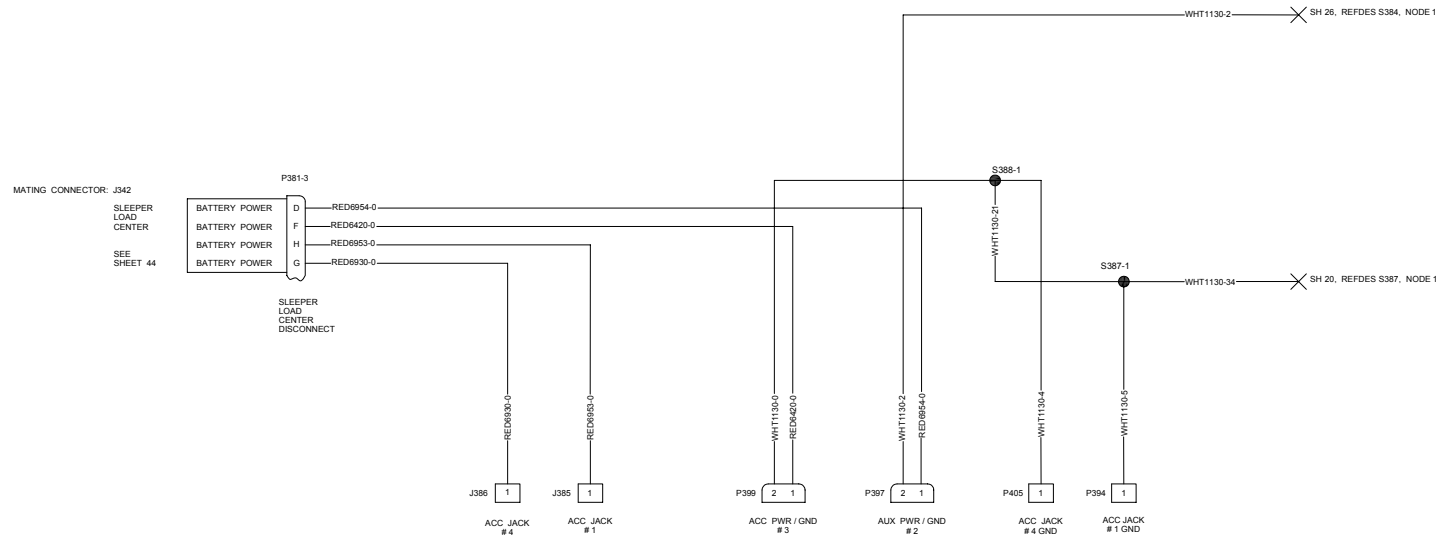

48" / 63" HIGH ROOF SLEEPER POWER ACCESS OUTLETS

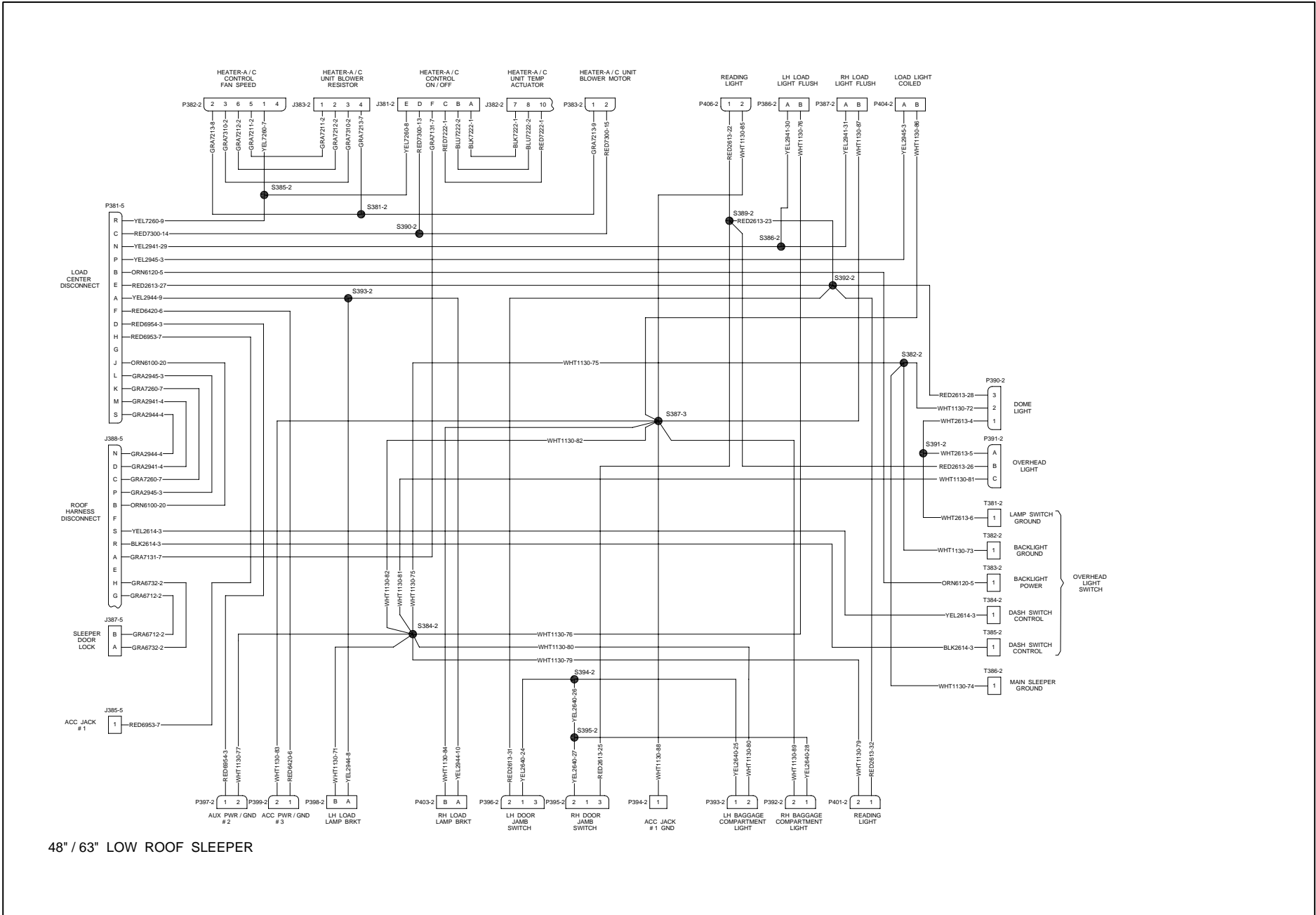

48" / 63" LOW ROOF SLEEPER



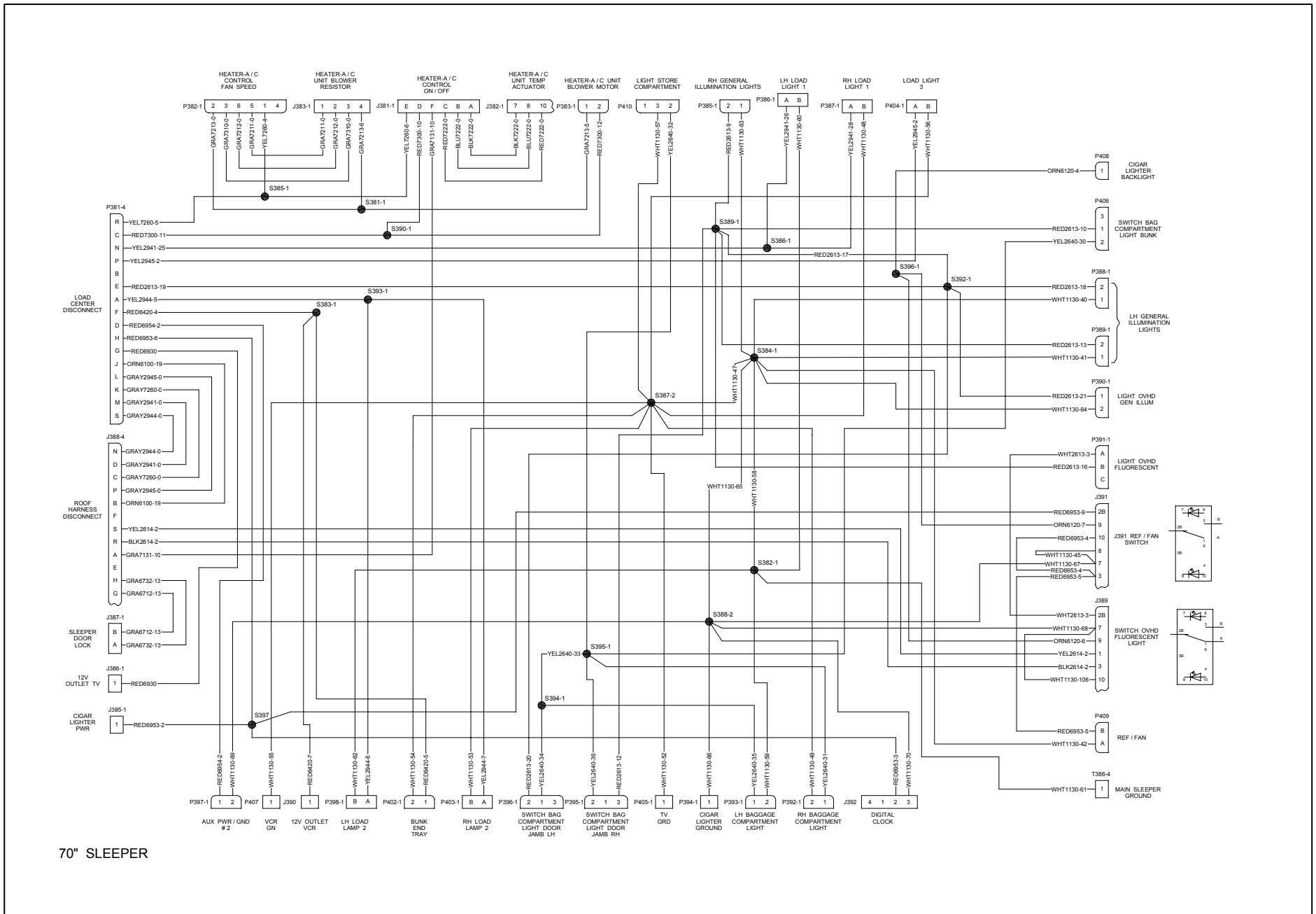

70" SLEEPER



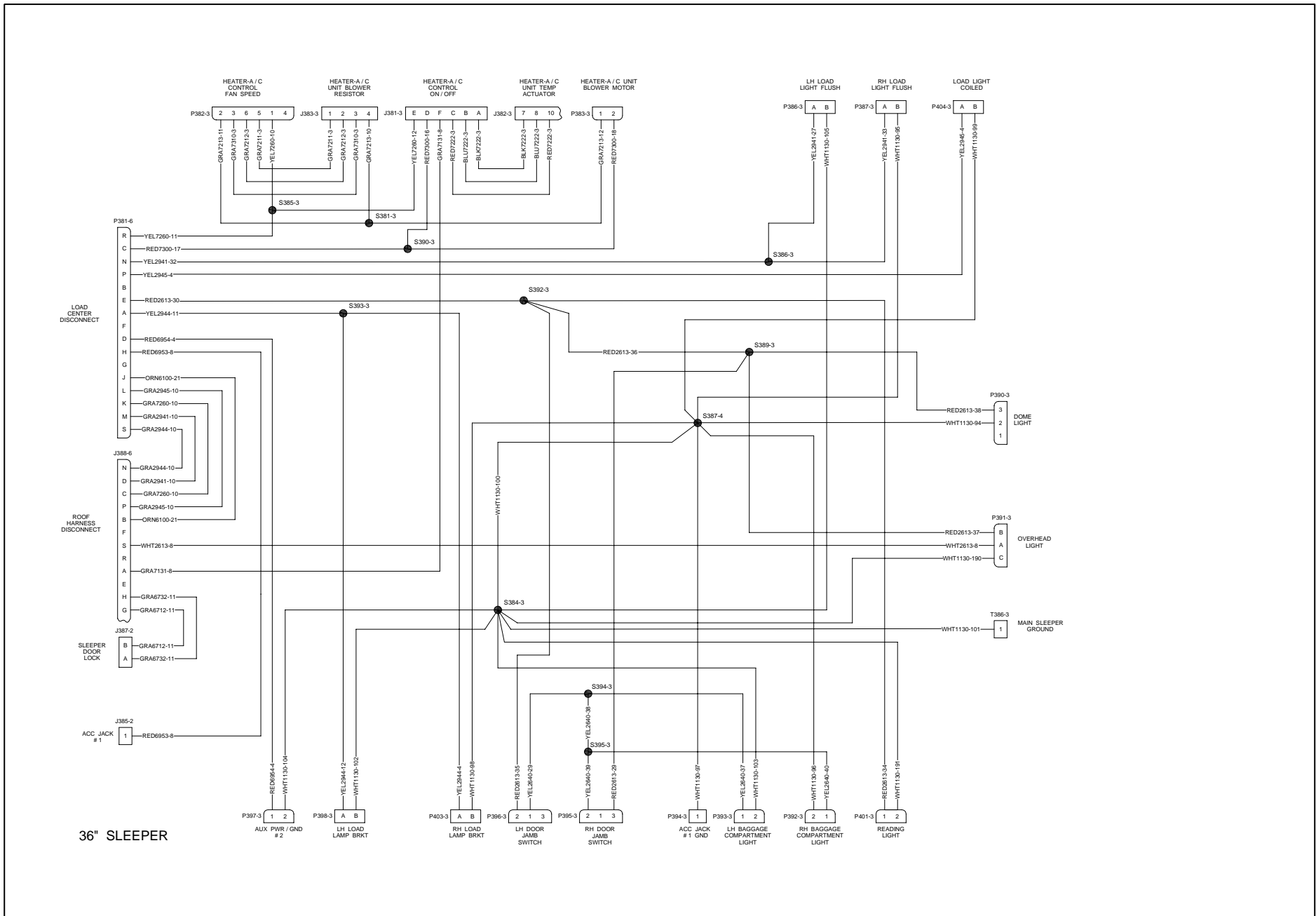

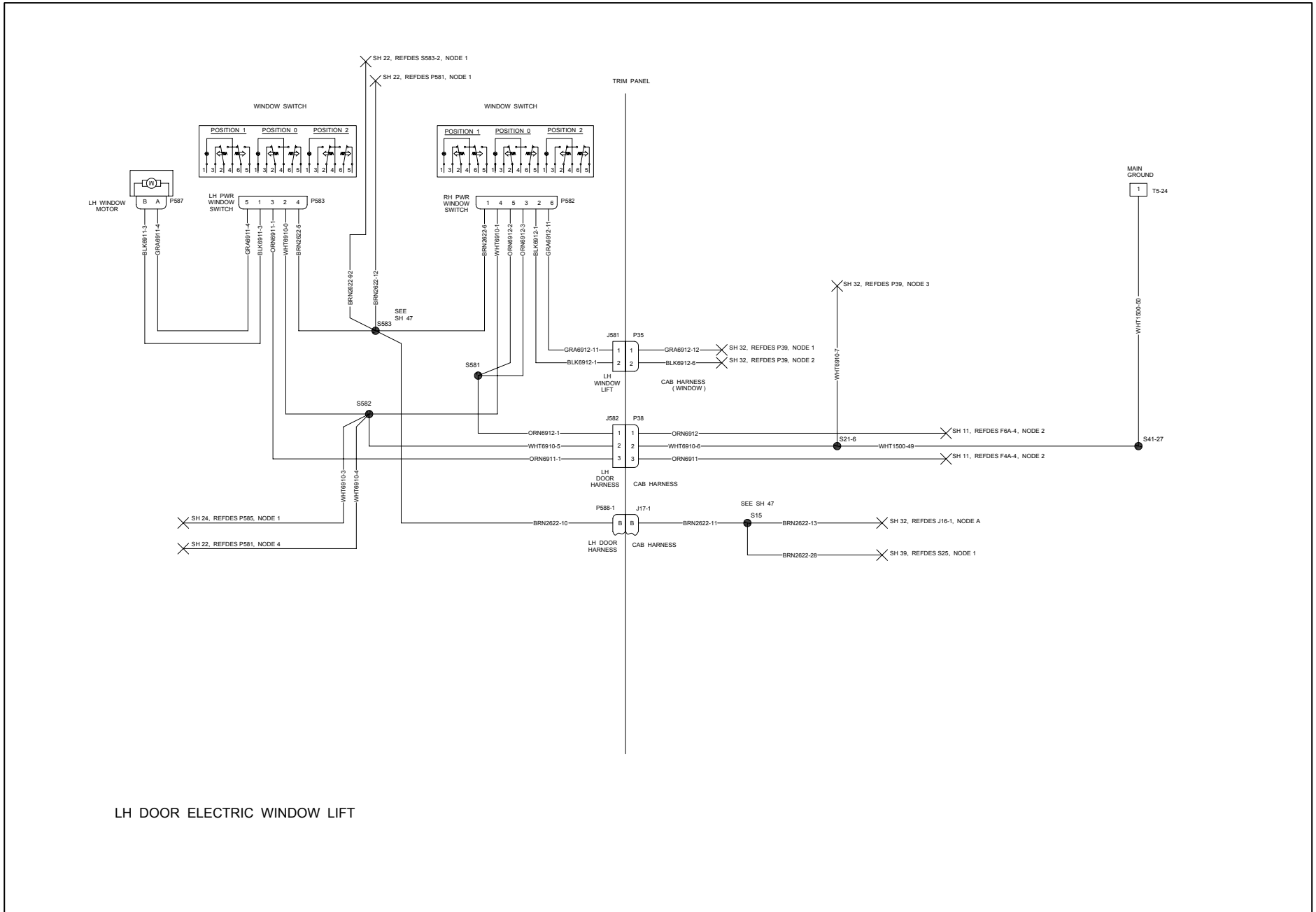

LH DOOR ELECTRIC WINDOW LIFT

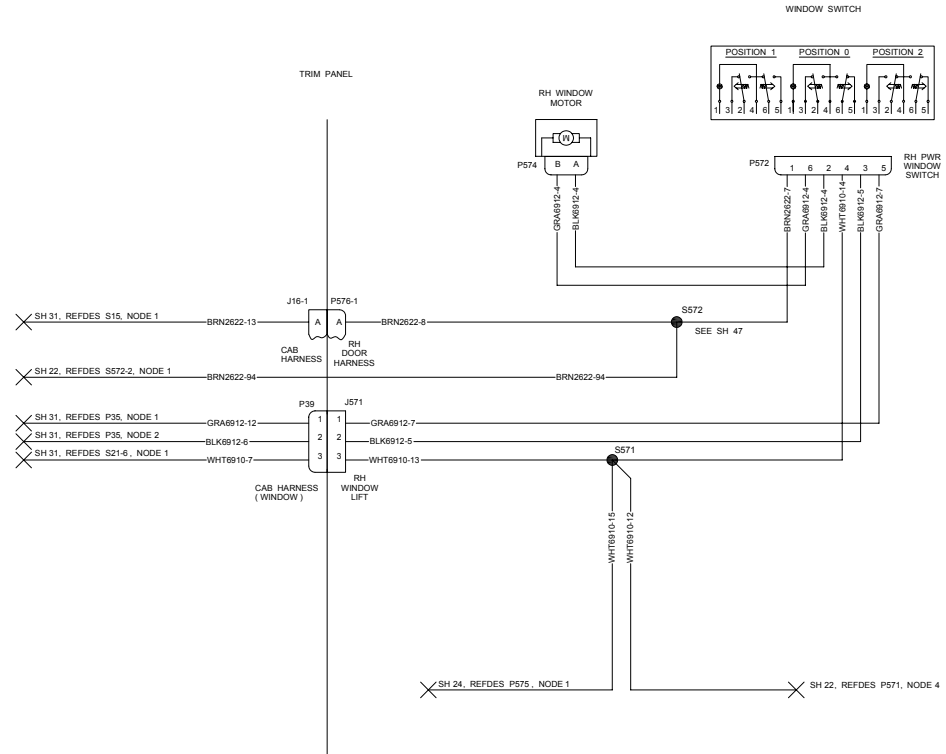

RH DOOR ELECTRIC WINDOW LIFT

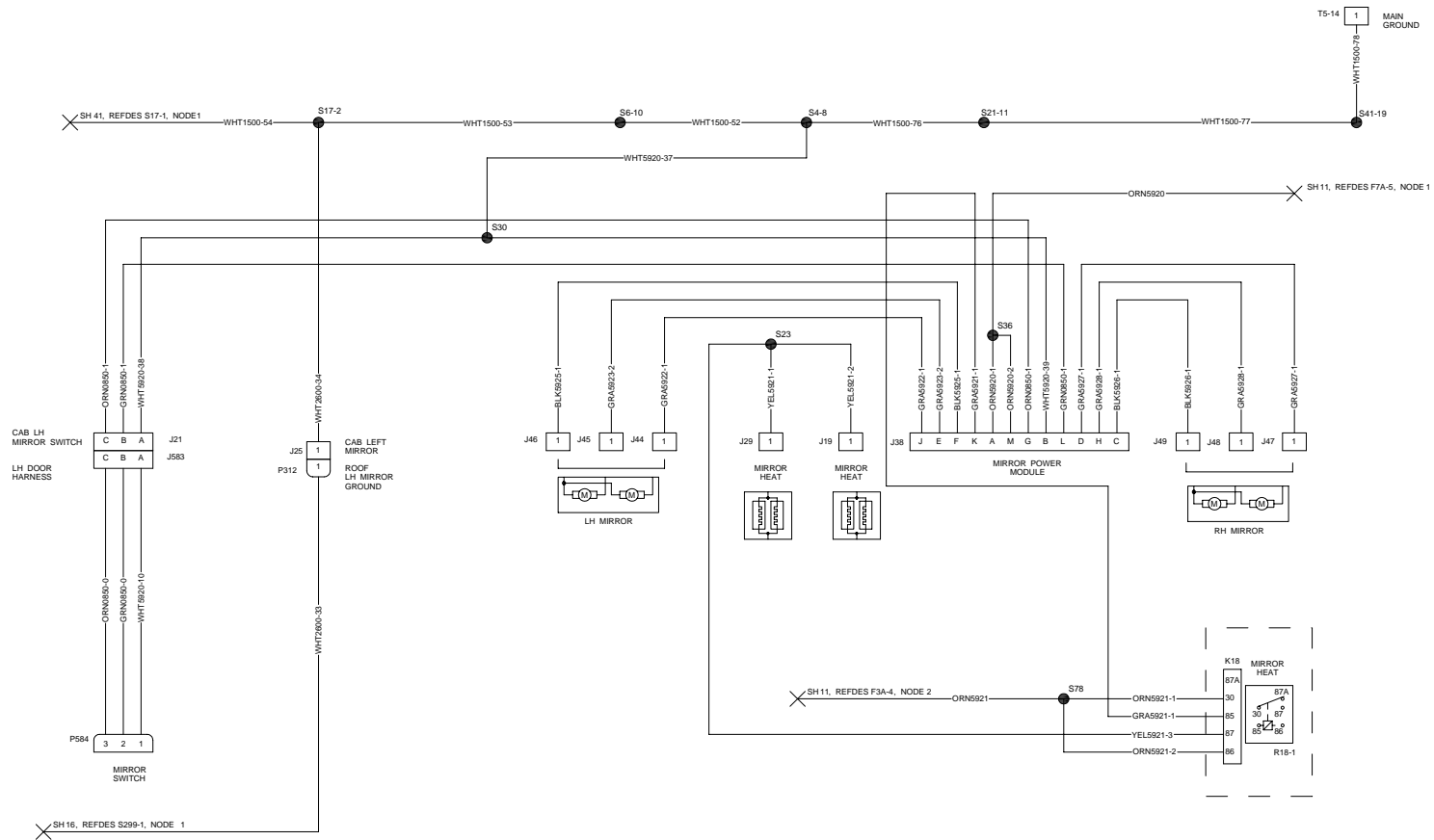

MIRRORS - STANDARD / MOTORIZED / HEATED & MIRROR CONTROL

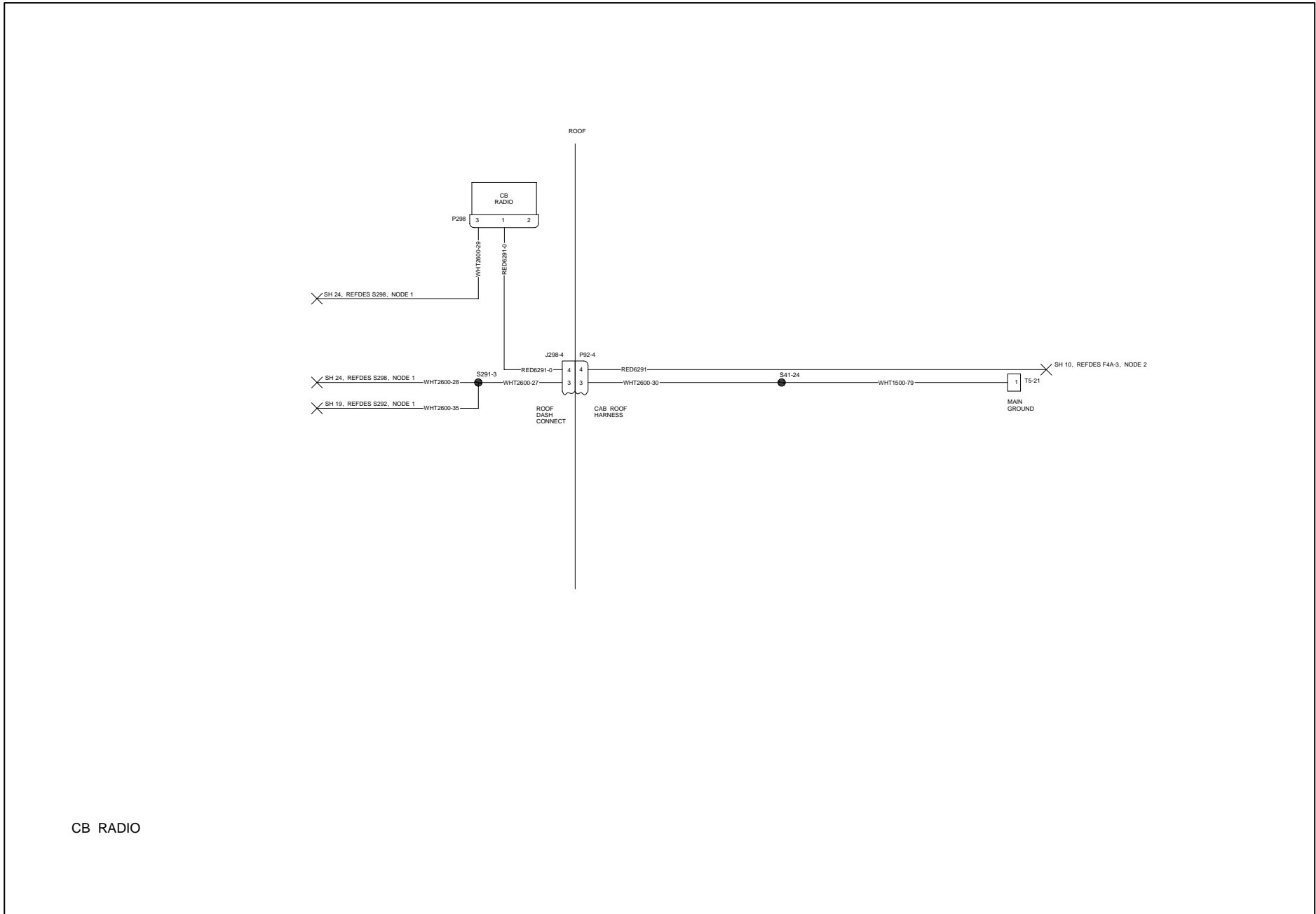

CB RADIO



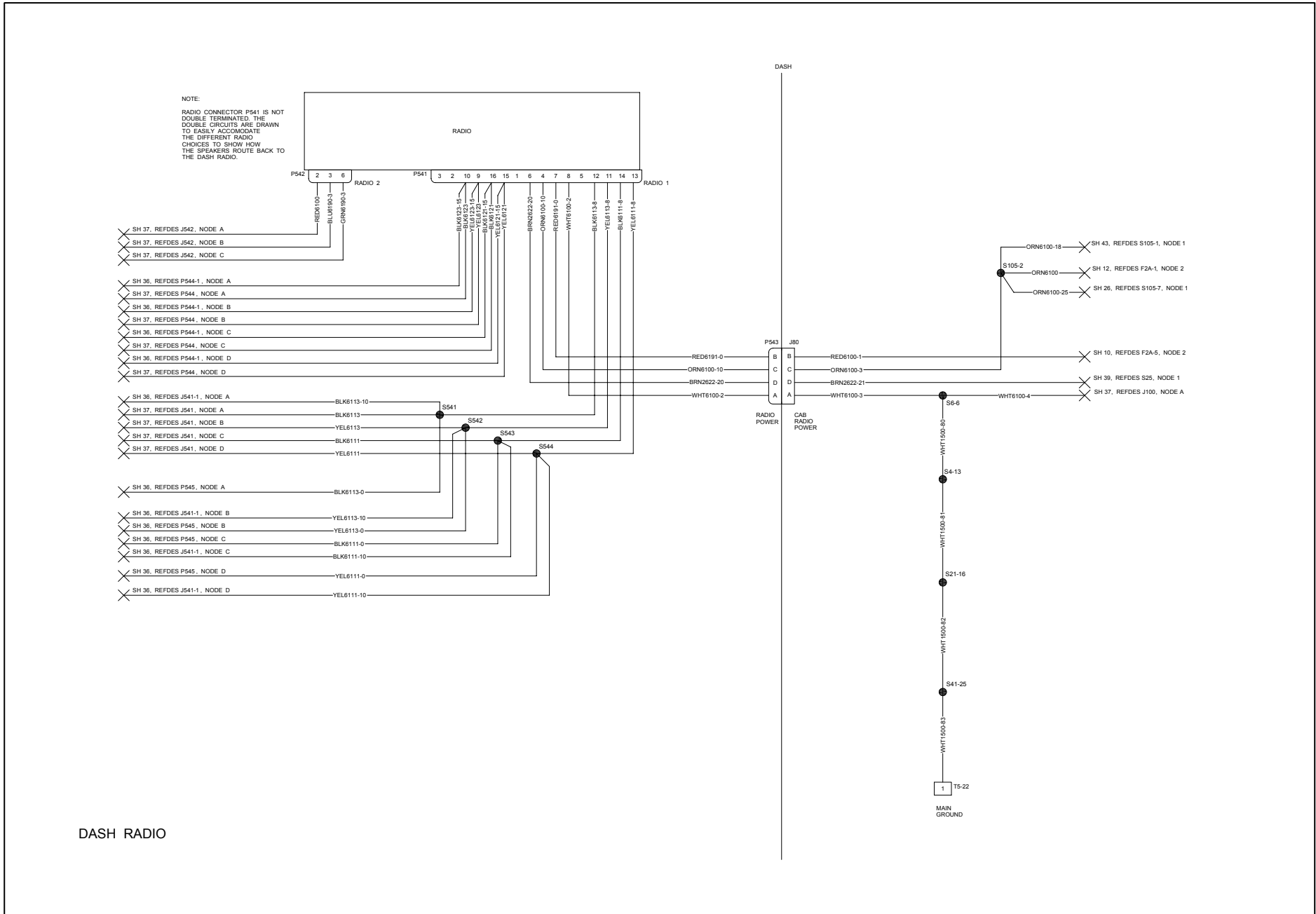

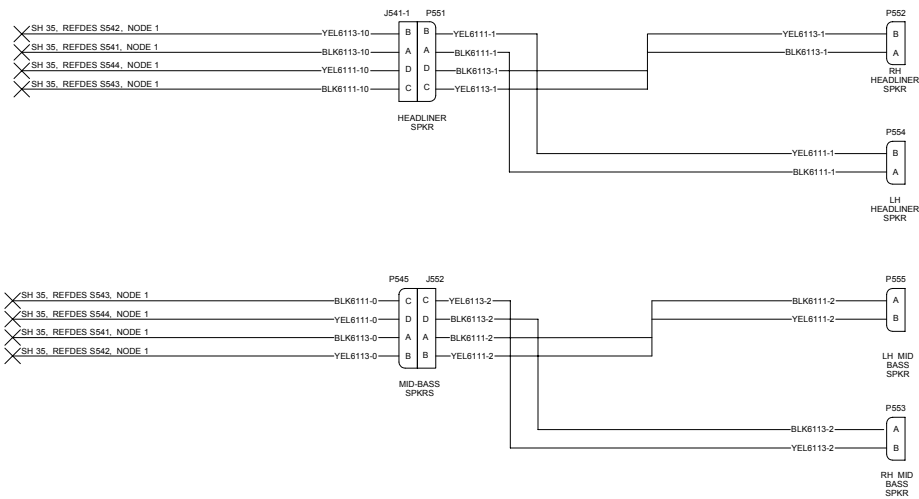
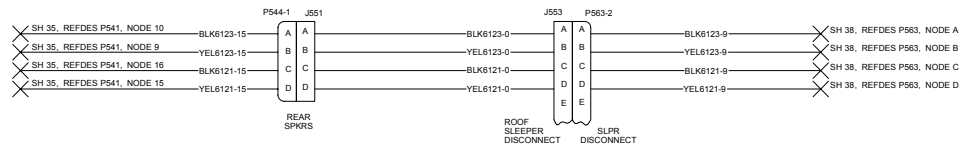

CAB ROOF SPEAKERS - CONCERT CLASS / CONCERT CLASS PREMIUM

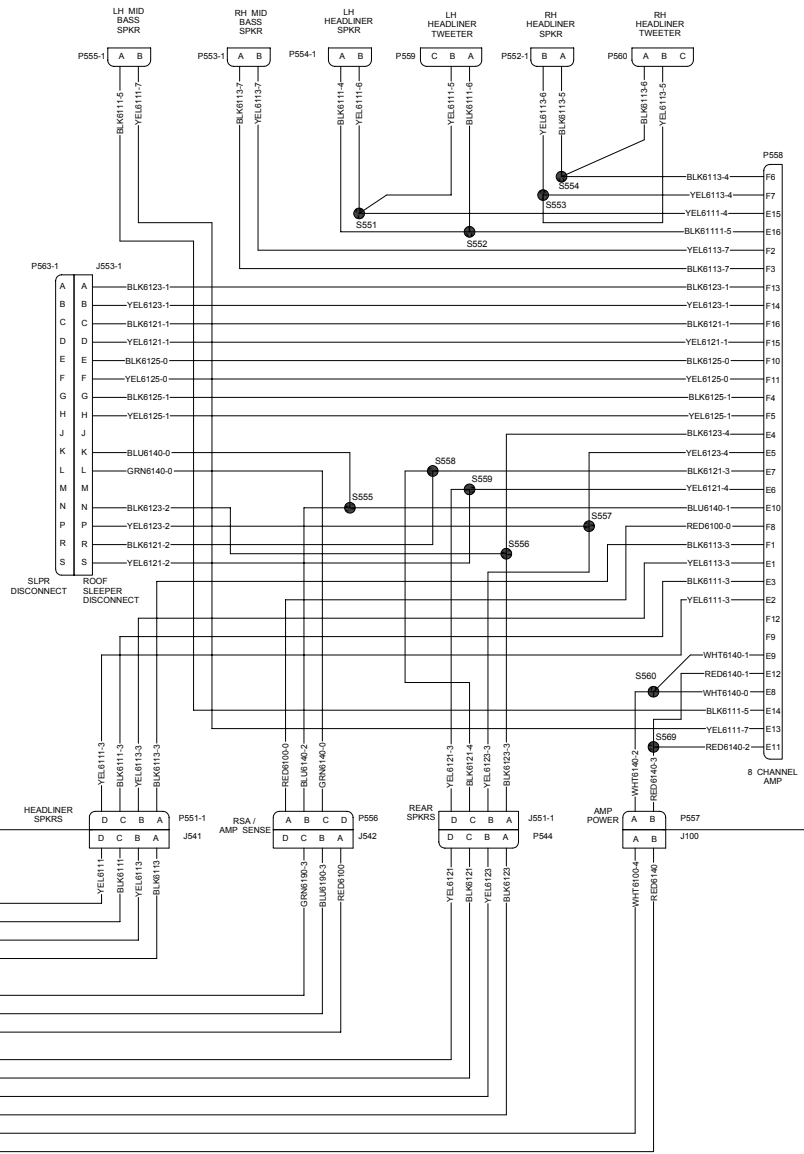

SEE SH 38 FOR SLEEPER CONNECTIONS

- ✕ SH 35, REFDES S544, NODE 1
- ✕ SH 35, REFDES S543, NODE 1
- ✕ SH 35, REFDES S542, NODE 1
- ✕ SH 35, REFDES S541, NODE 1
- ✕ SH 35, REFDES P542, NODE 6
- ✕ SH 35, REFDES P542, NODE 3
- ✕ SH 35, REFDES P542, NODE 2
- ✕ SH 35, REFDES P541, NODE 15
- ✕ SH 35, REFDES P541, NODE 16
- ✕ SH 35, REFDES P541, NODE 9
- ✕ SH 35, REFDES P541, NODE 10
- ✕ SH 35, REFDES S6-6, NODE 1
- ✕ SH 10, REFDES FA4-5, NODE 2

CAB ROOF SPEAKERS- CONCERT CLASS EHD



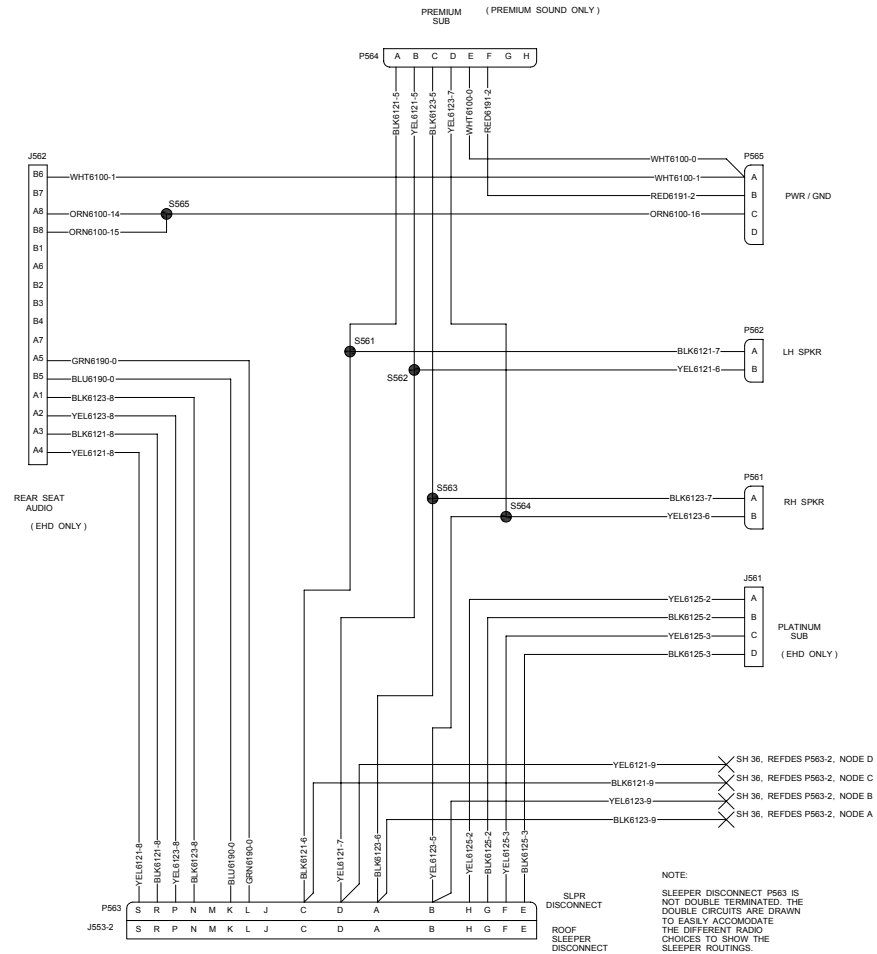

RADIO- 48" / 63" / 70" SLEEPER



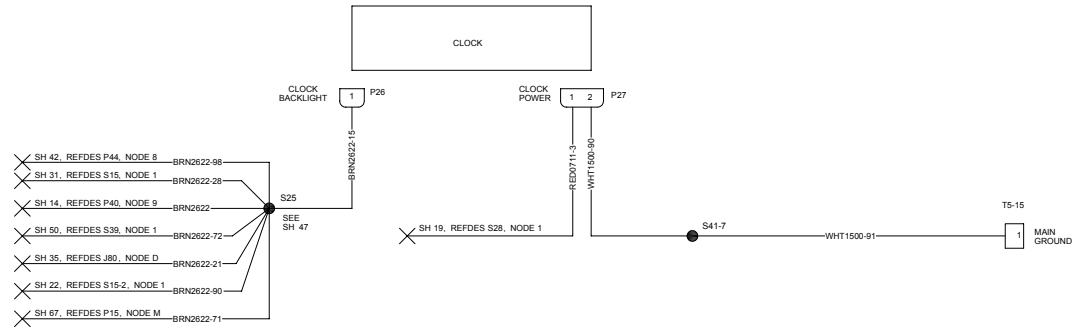

CLOCK

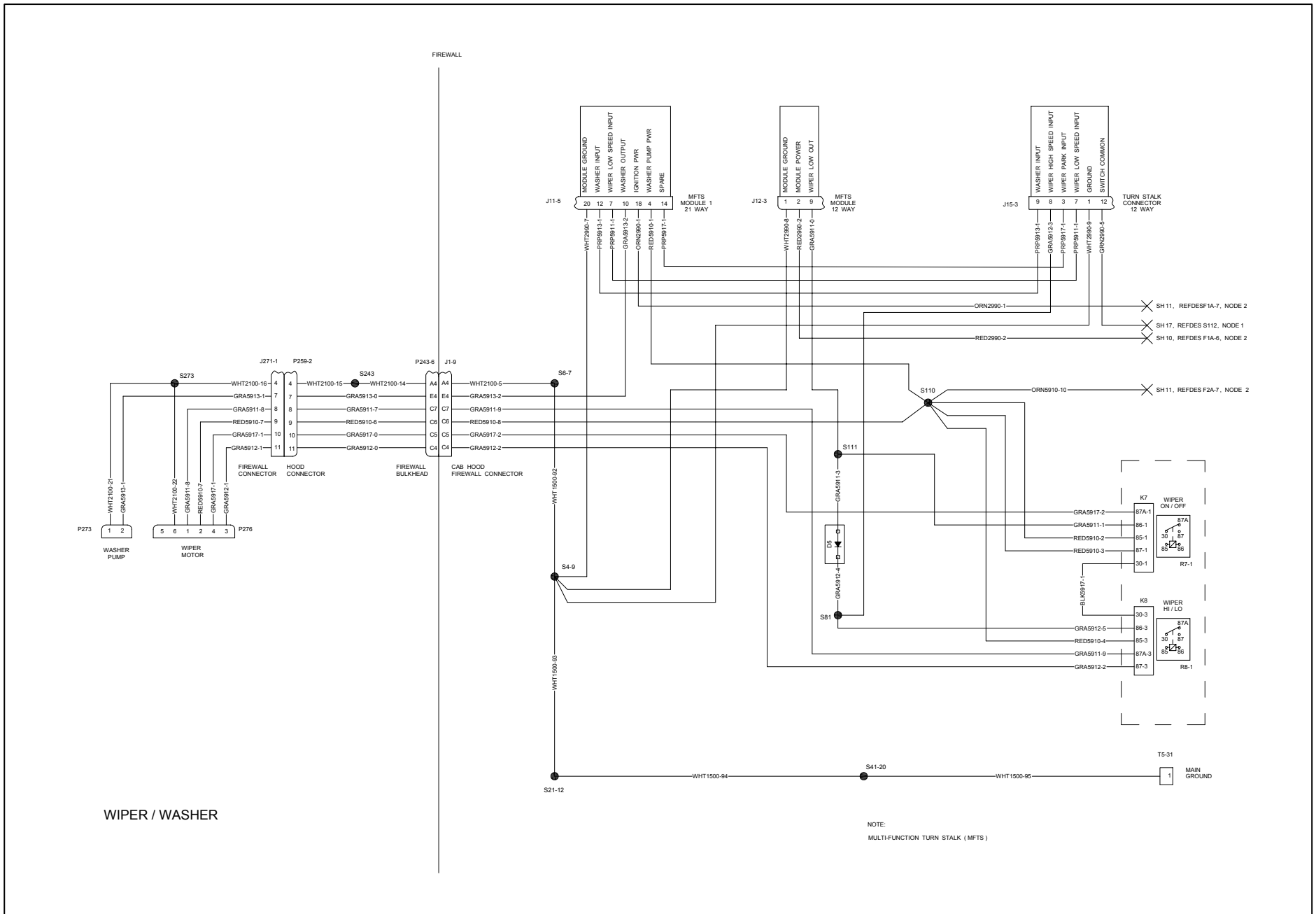

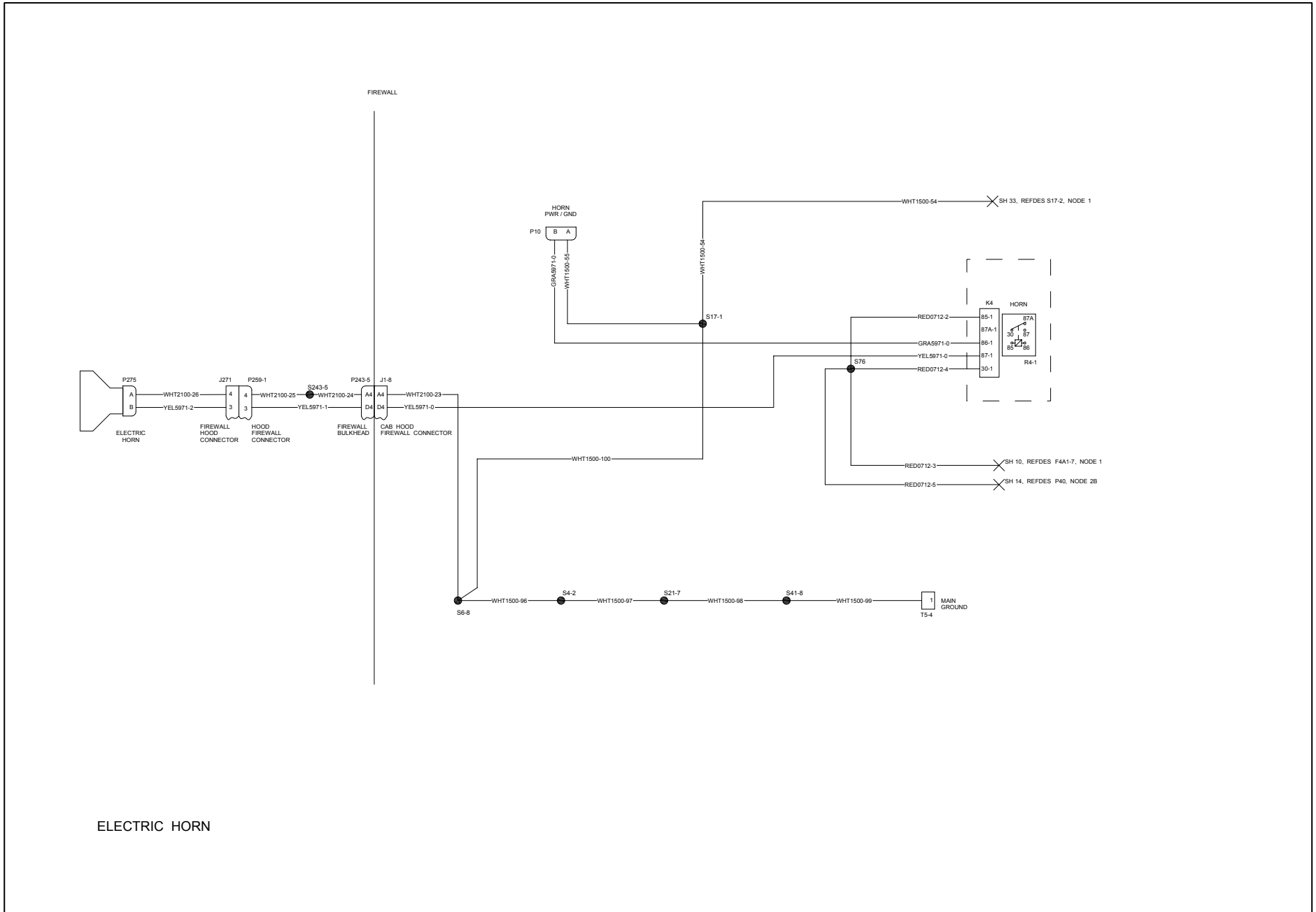

ELECTRIC HORN

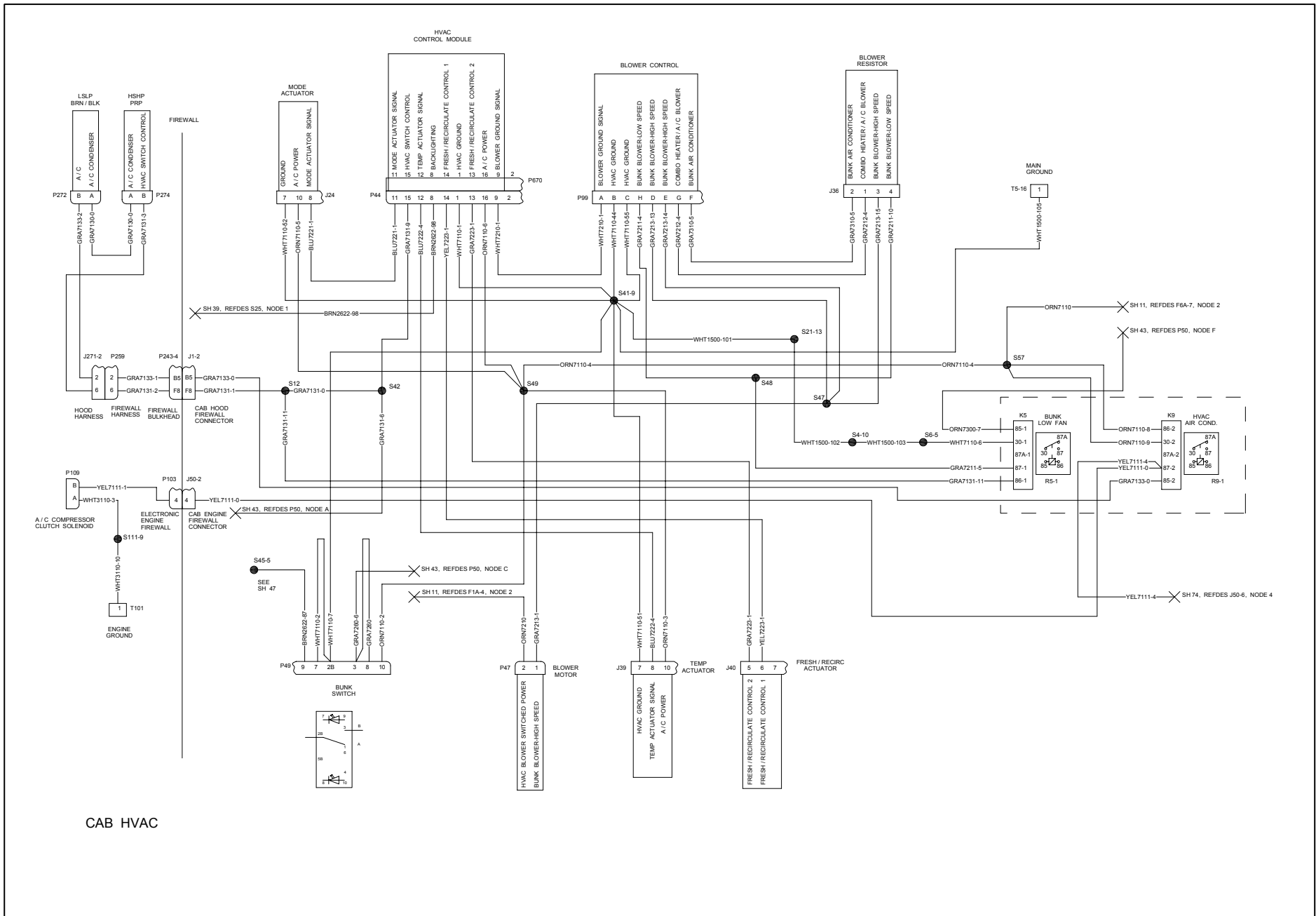

CAB HVAC



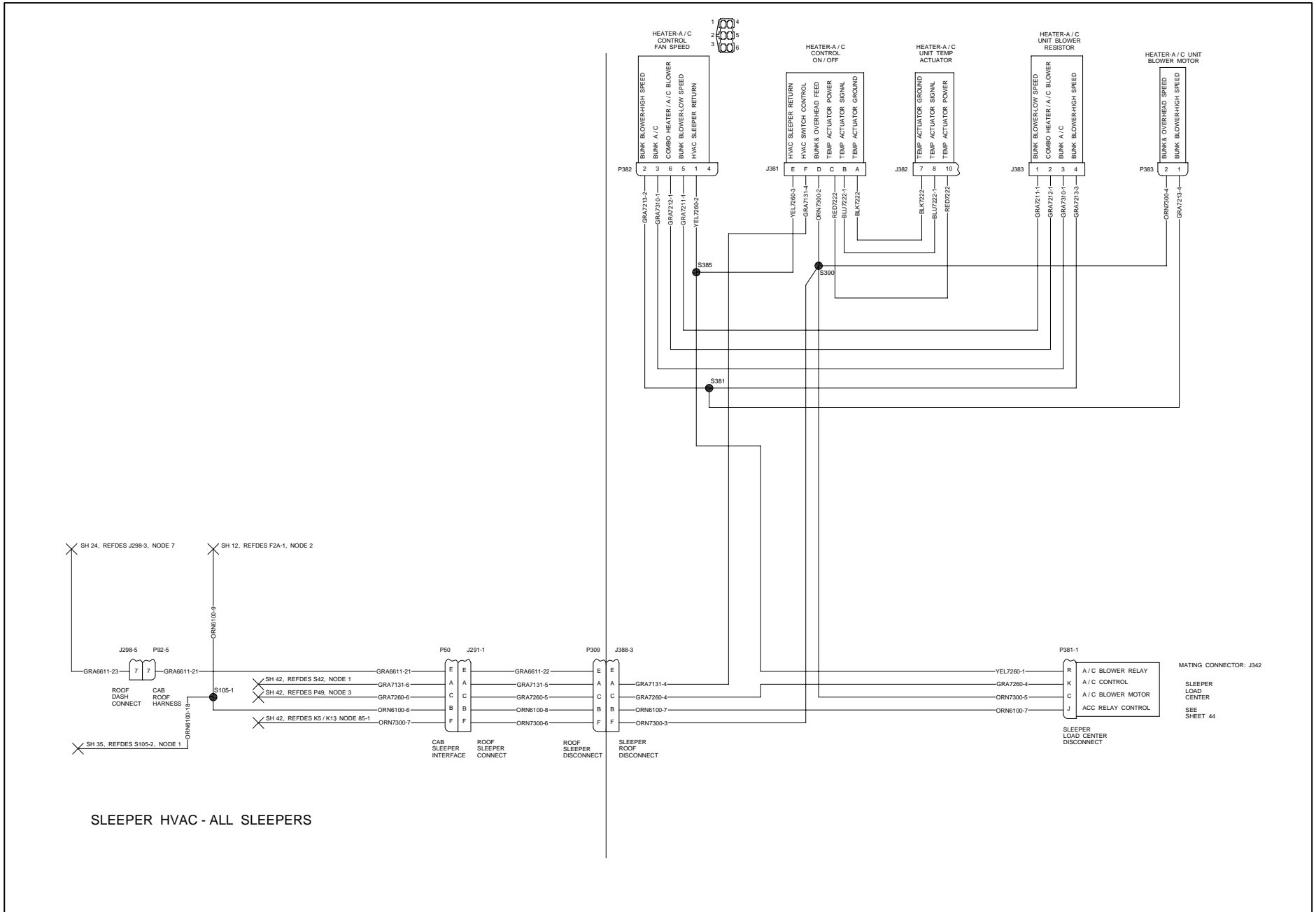

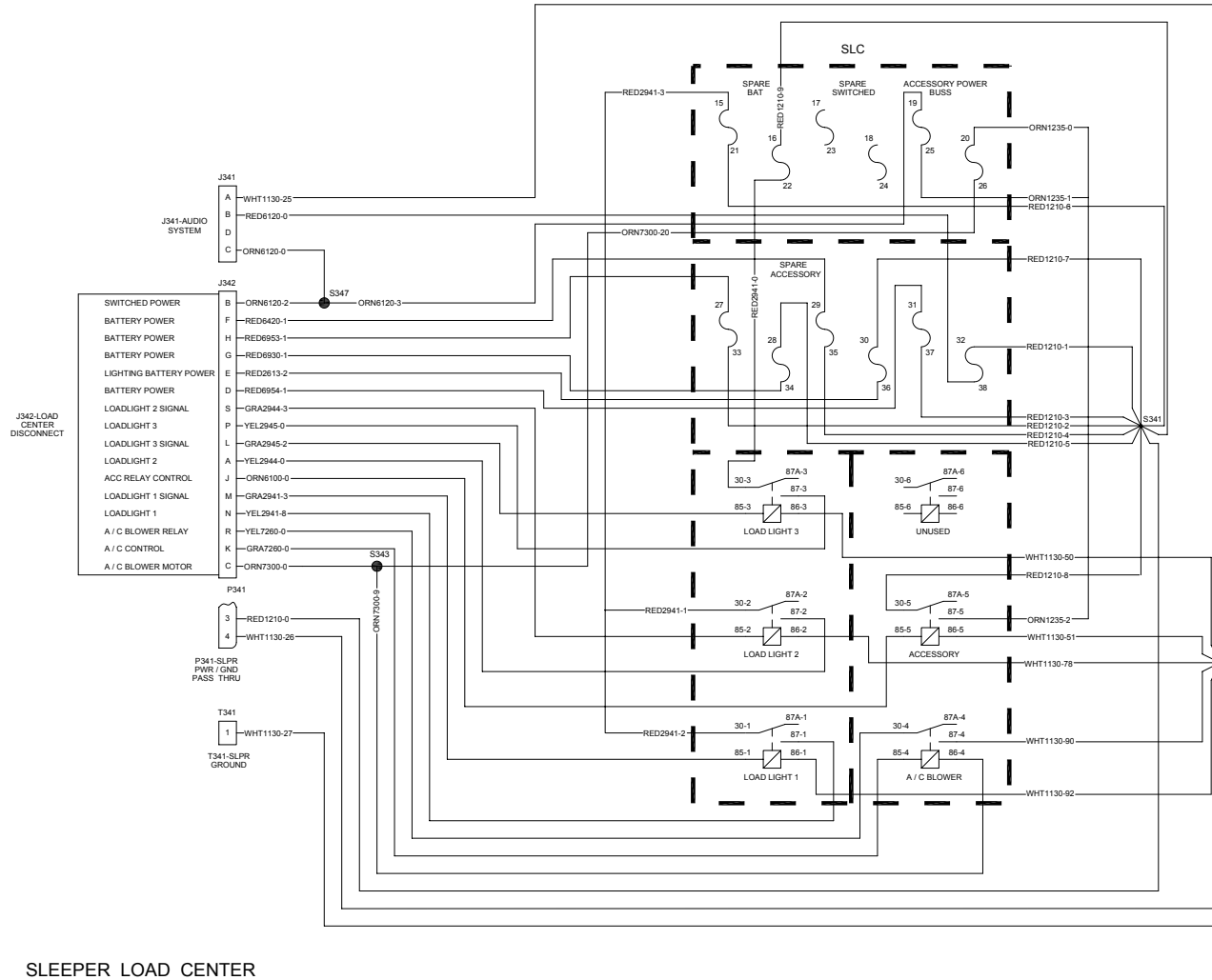

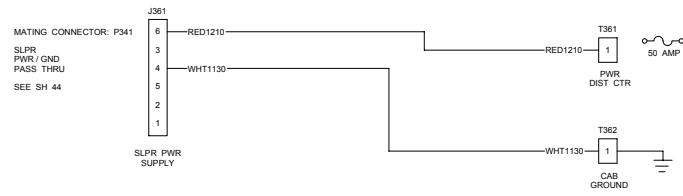

SLEEPER POWER SUPPLY HARNESS

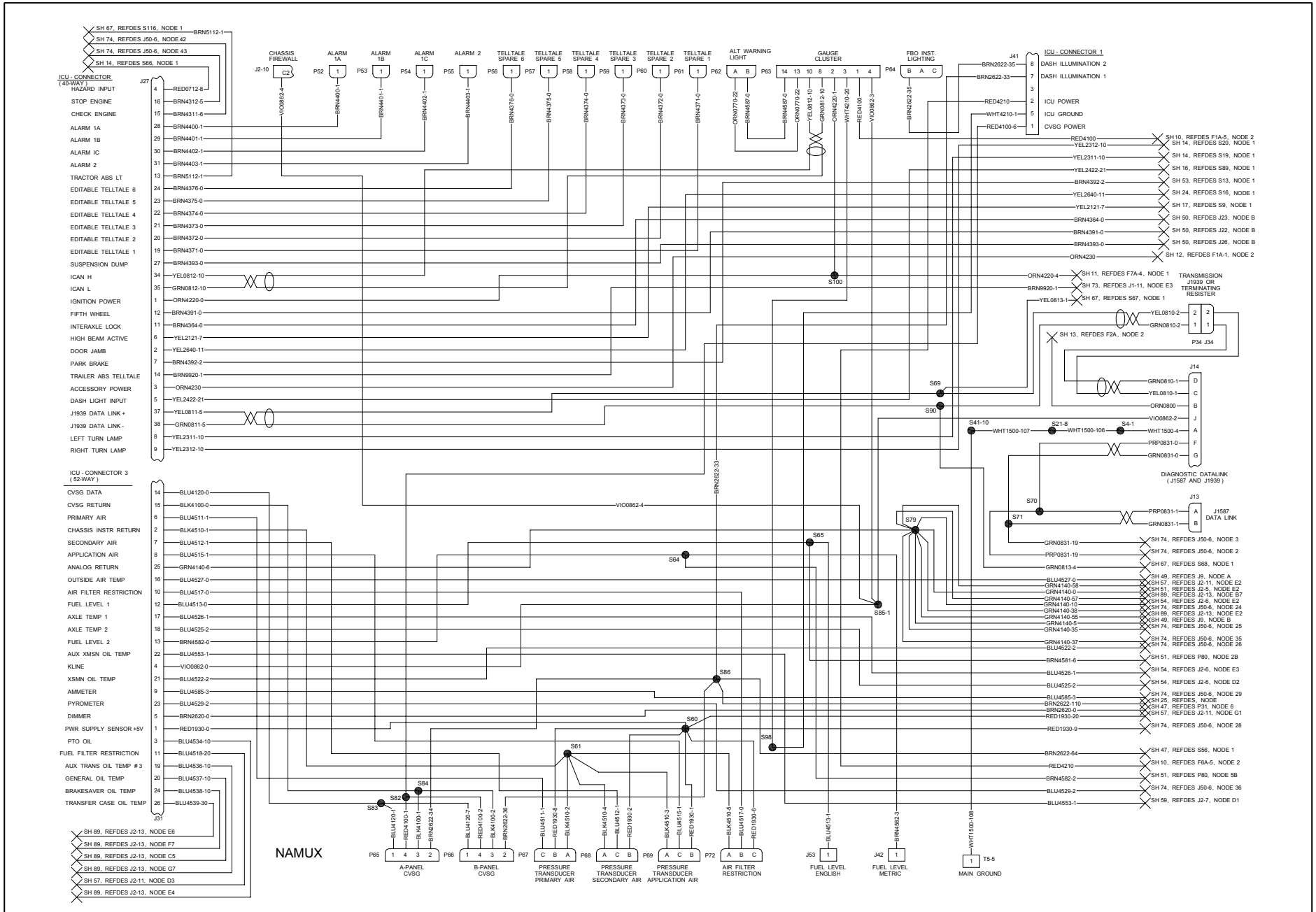

A DIVISION OF PACCAR

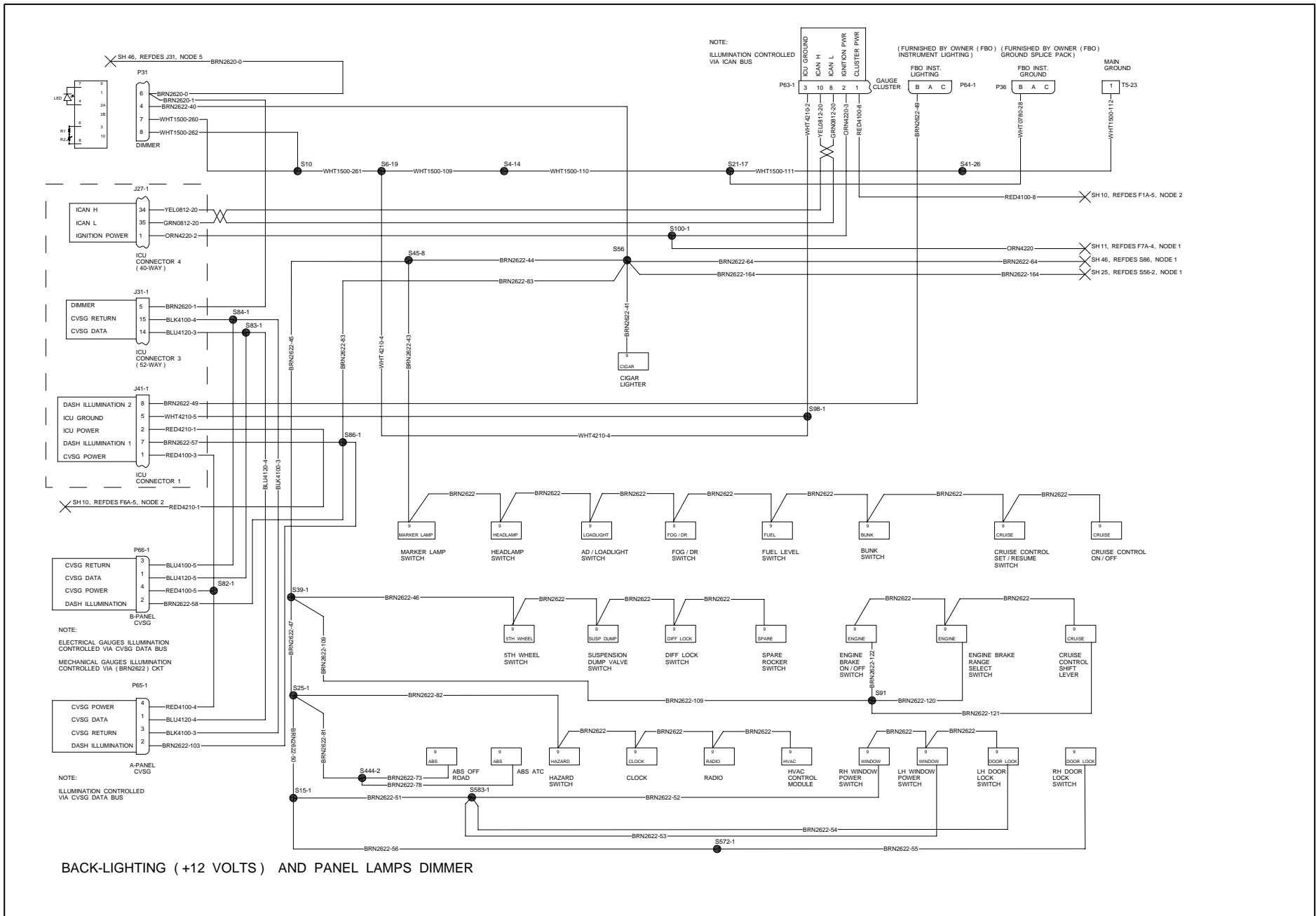

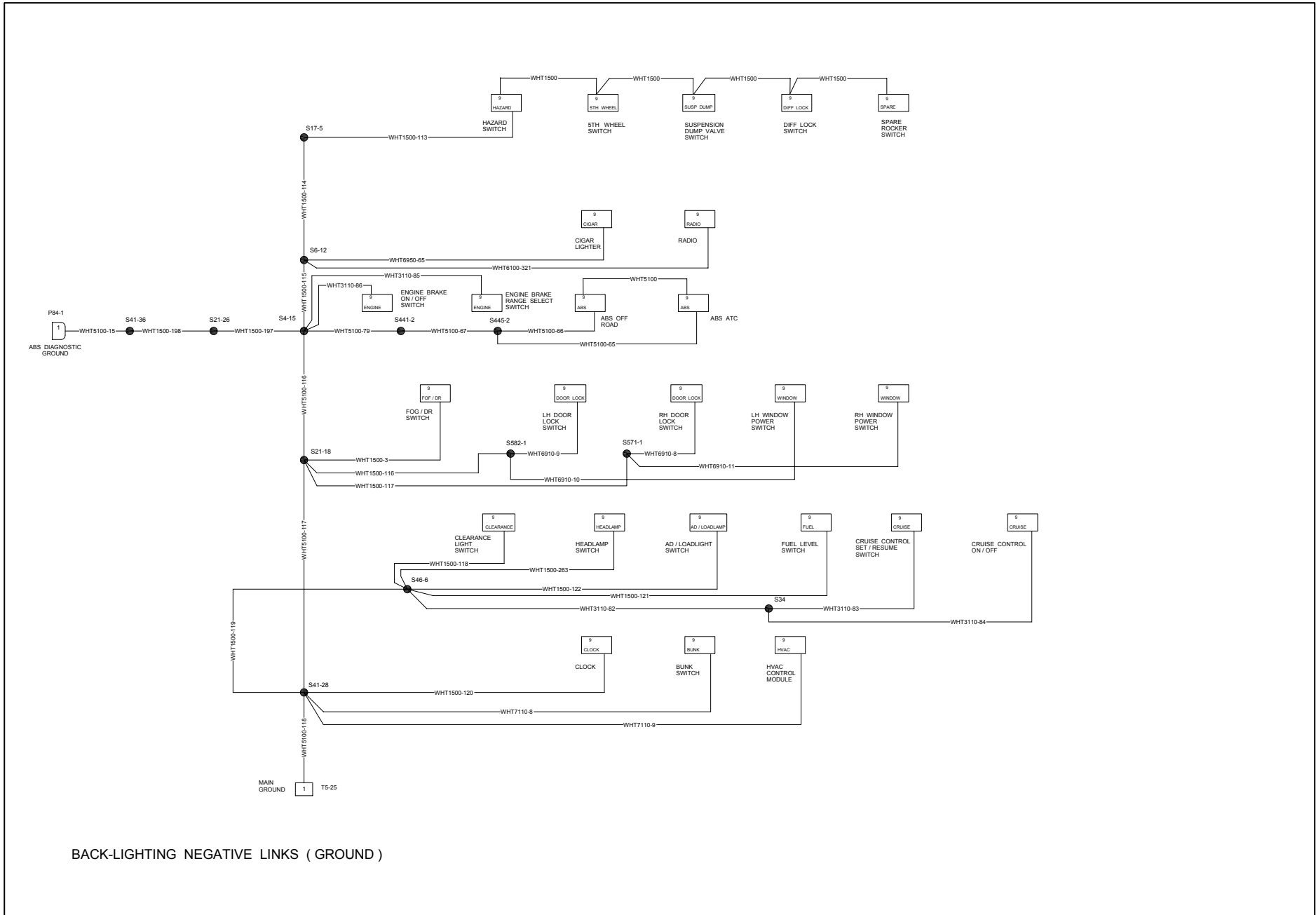

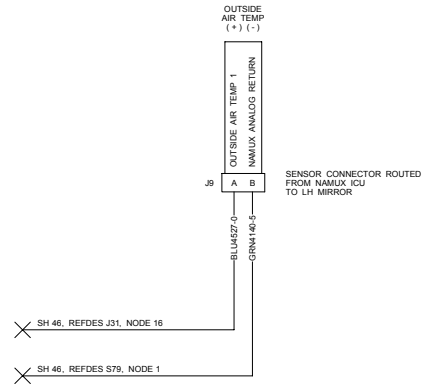

OUTSIDE AIR TEMPERATURE

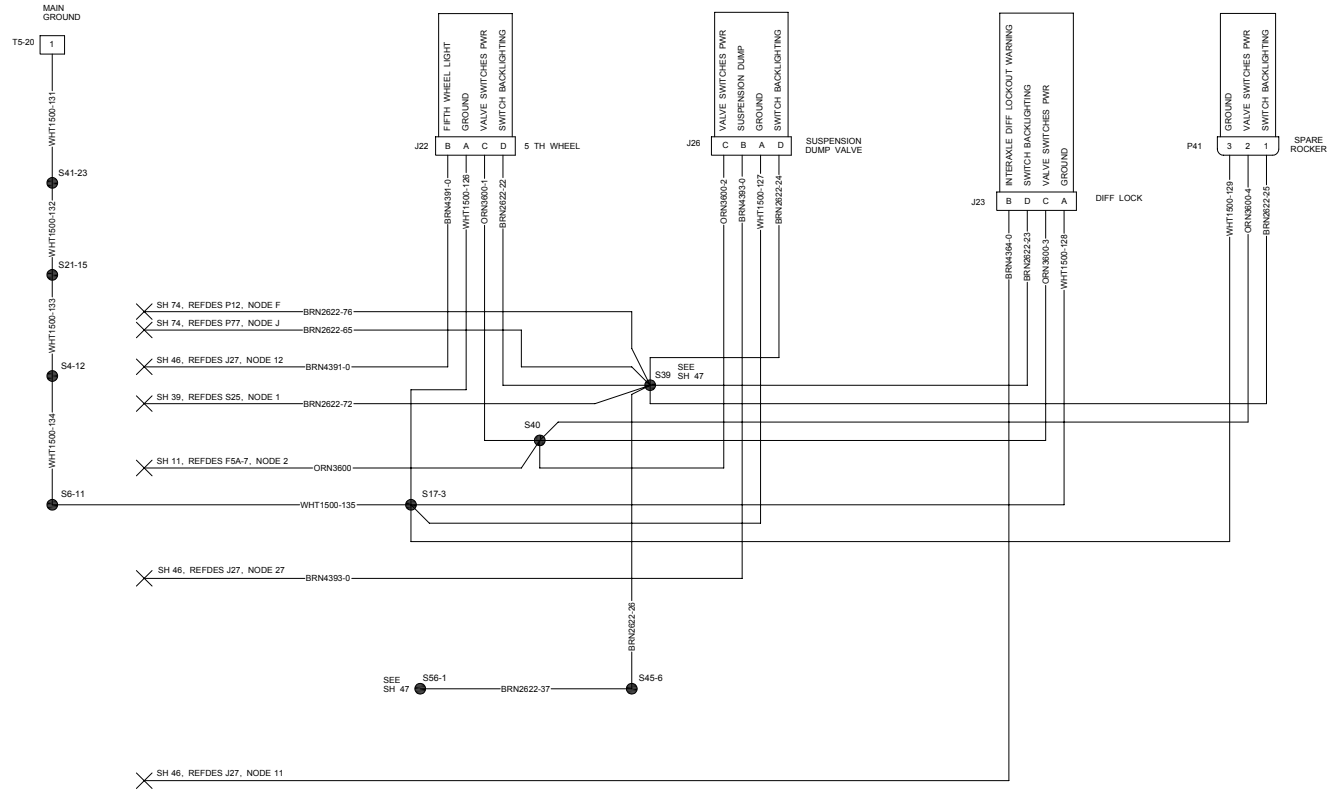

FIFTH WHEEL / DIFF LOCK / SUSPENSION DUMP VALVE / SPARE ROCKER SWITCHES



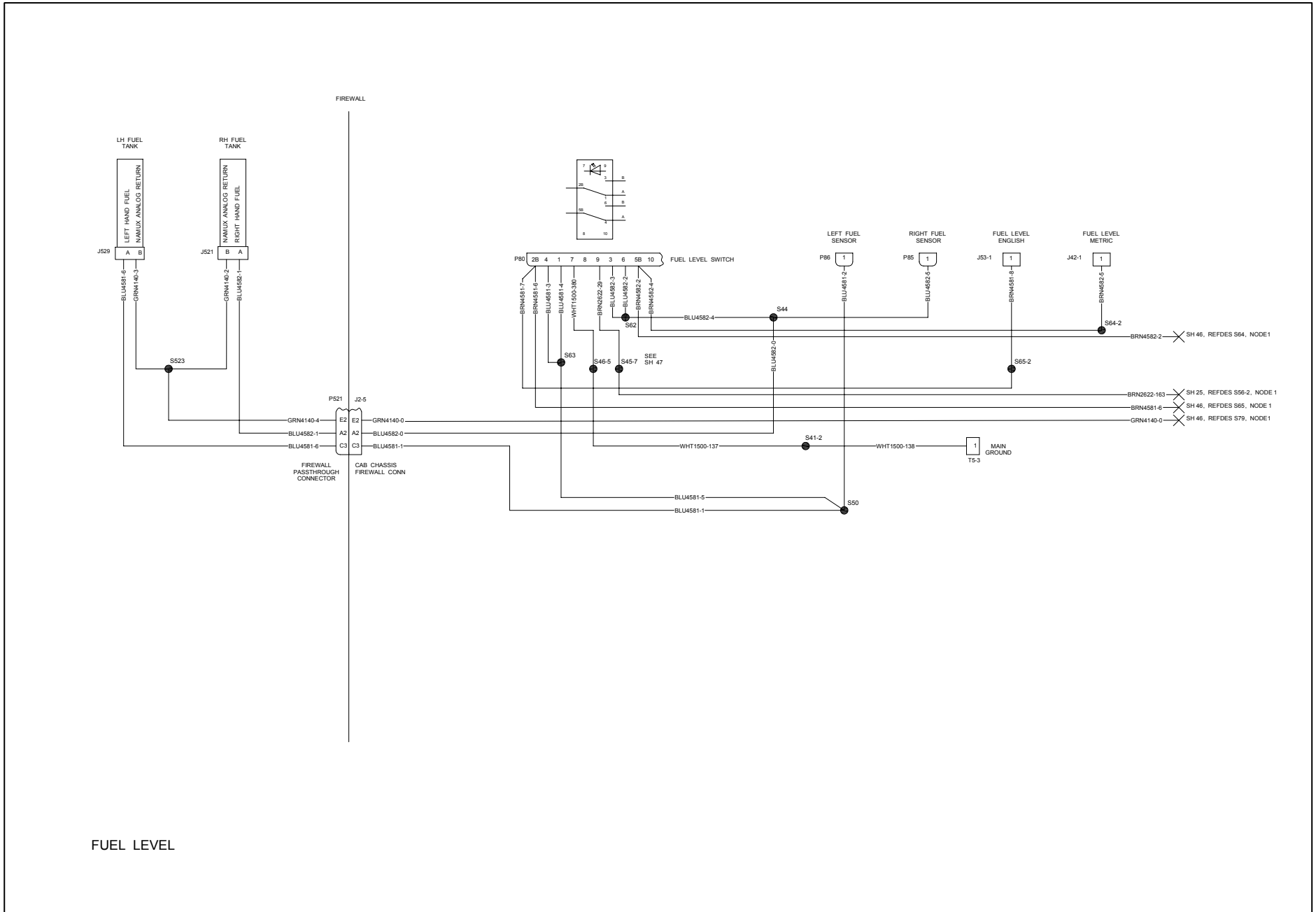

FUEL LEVEL

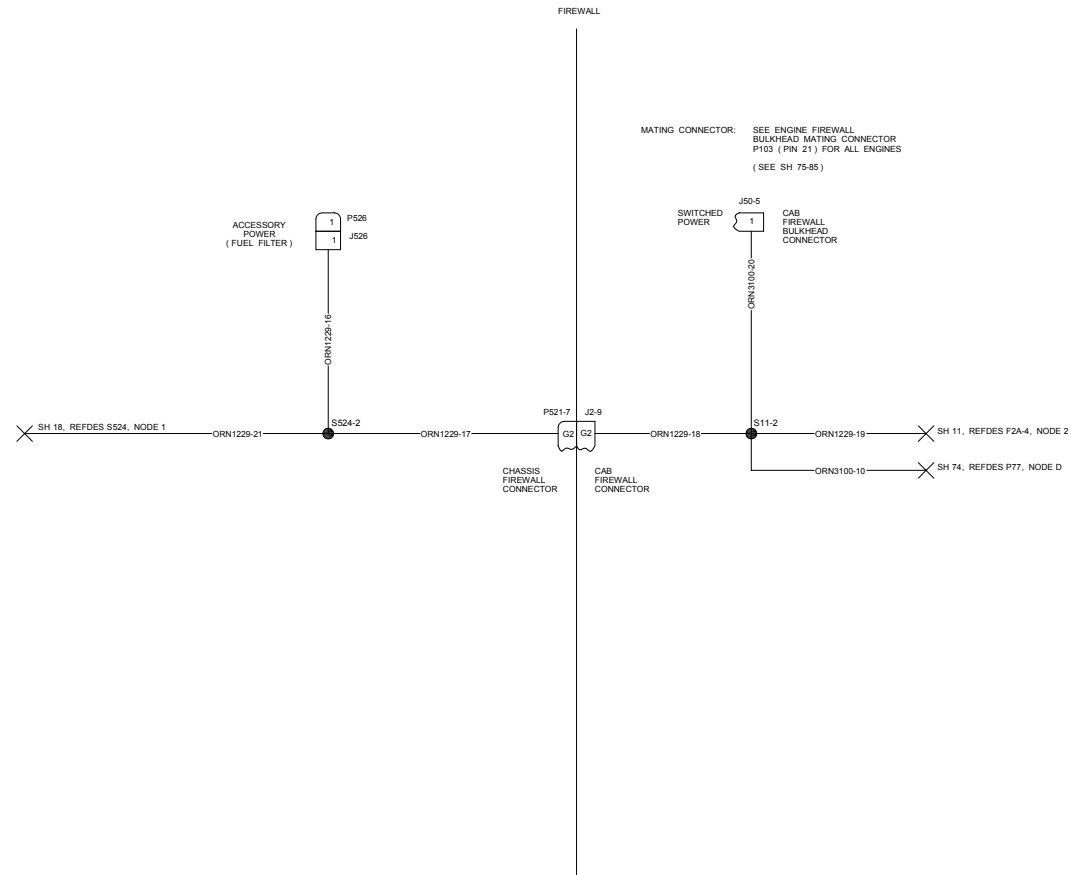

FUEL FILTER - ACCESSORY POWER

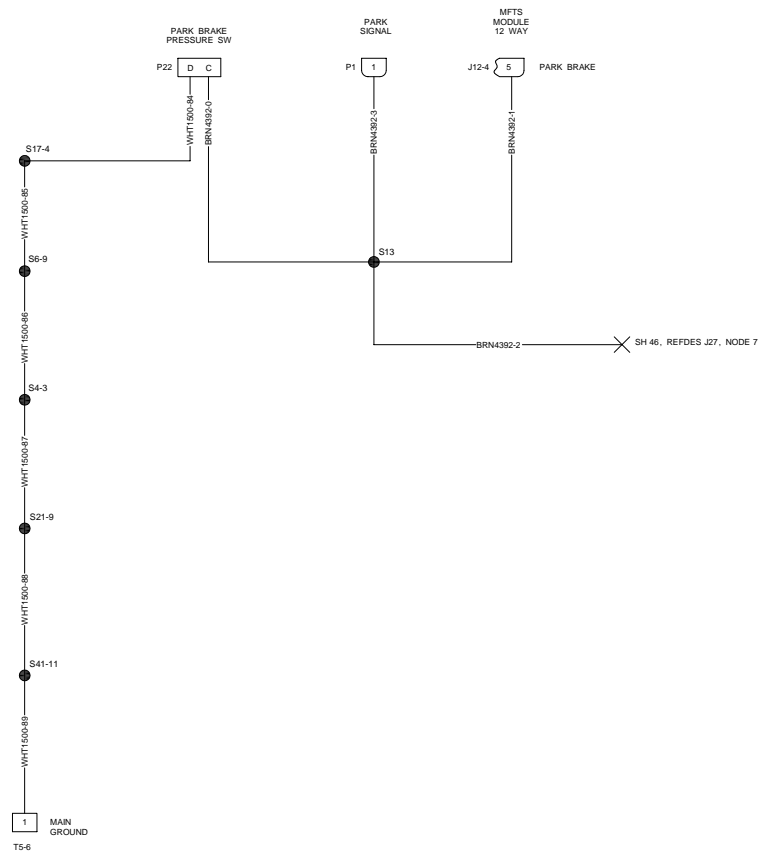

NOTE:
MULTI-FUNCTION TURN STALK (MFTS)

PARK BRAKE

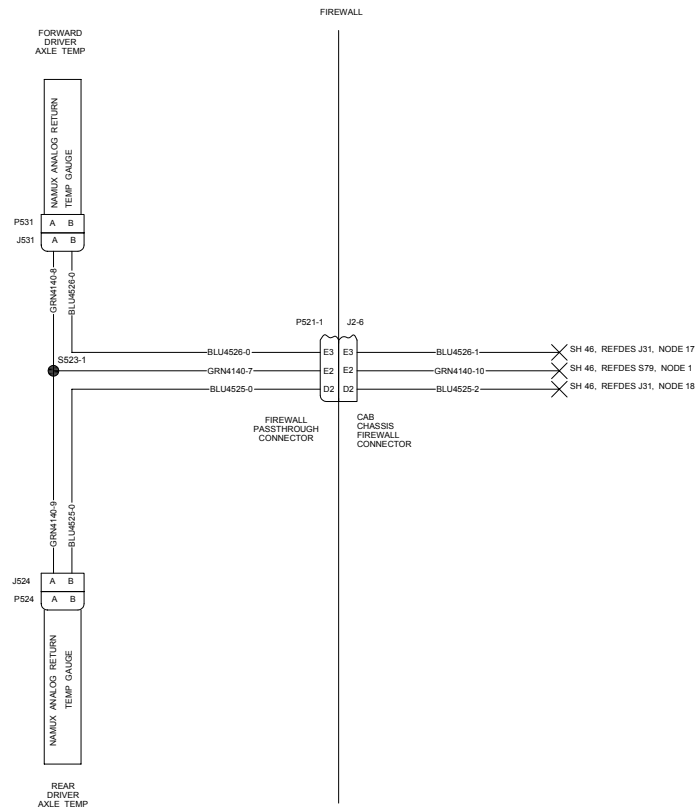

FORWARD AND REAR DRIVER AXLE TEMP

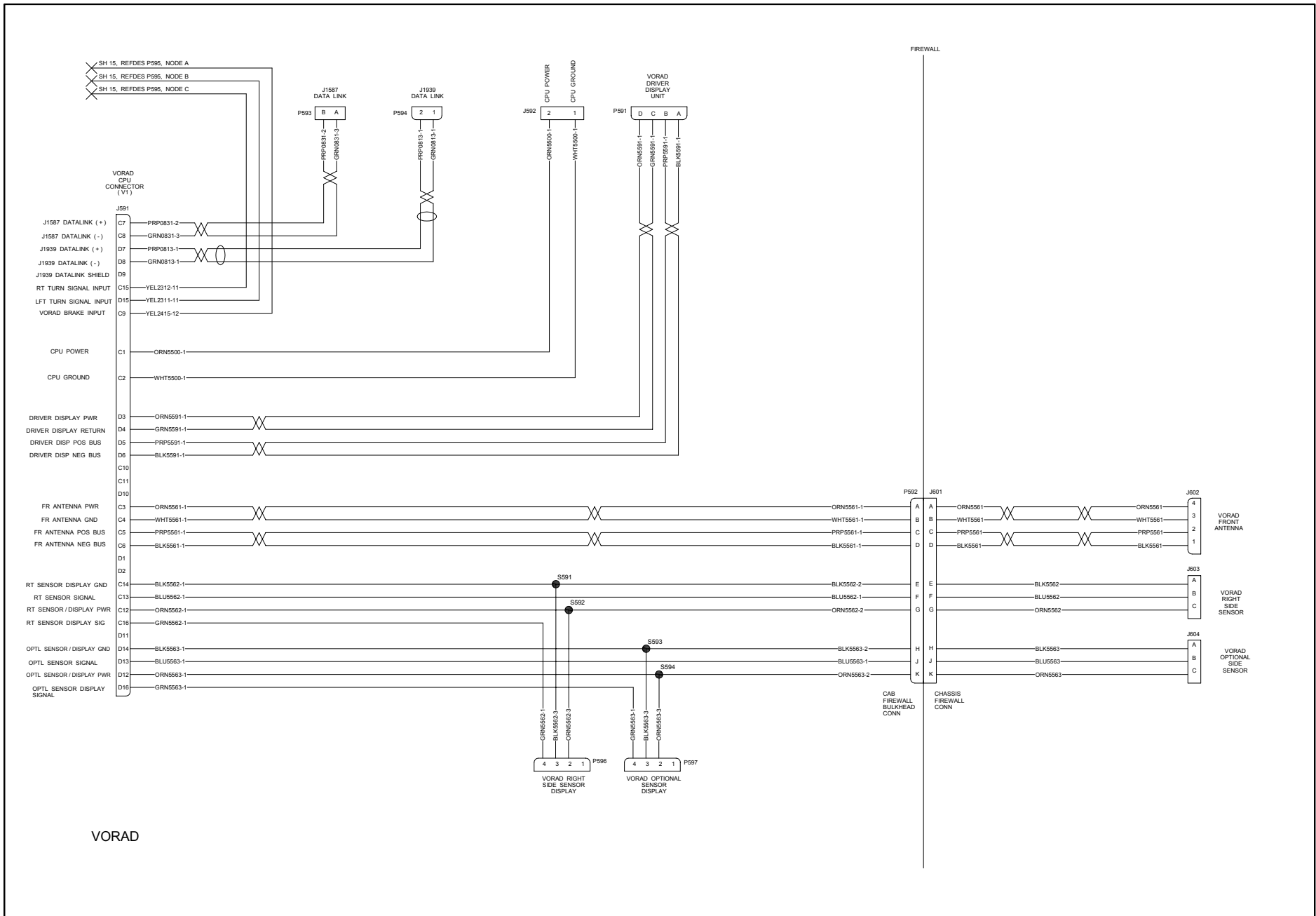

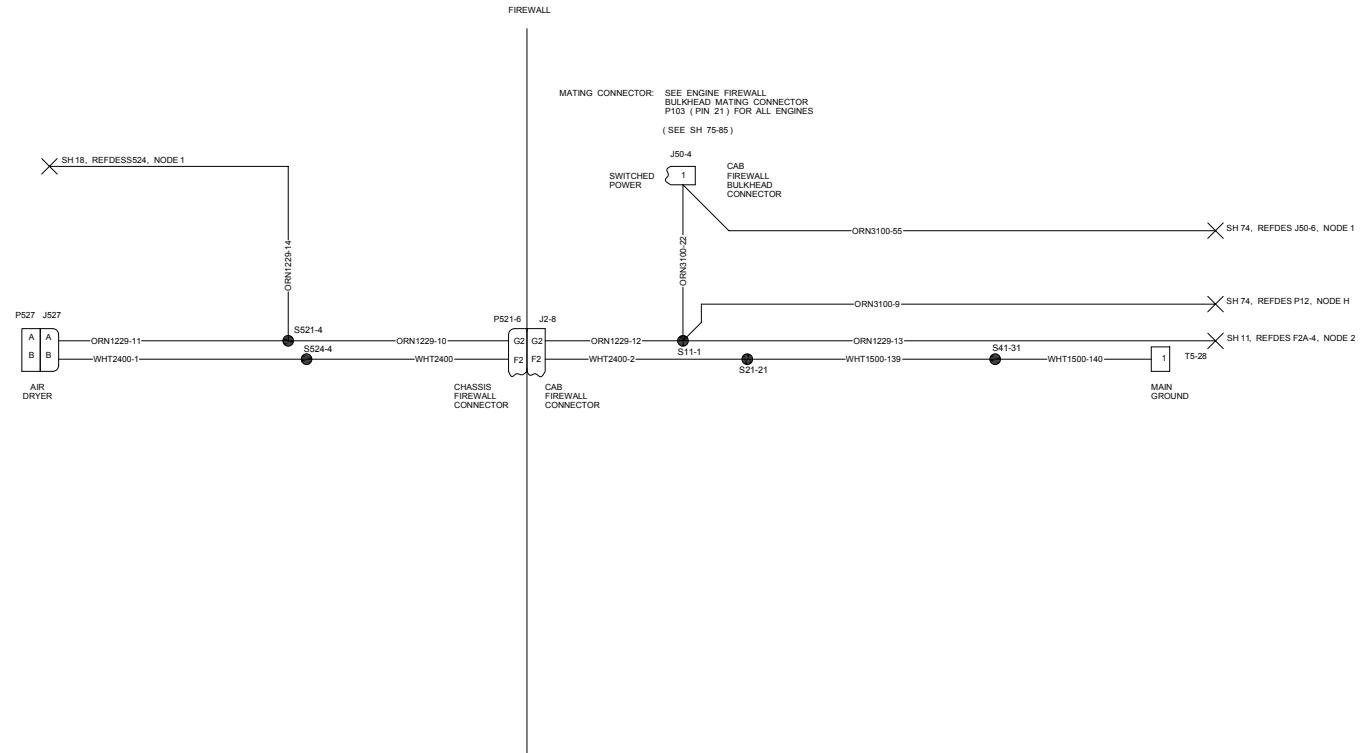

AIR DRYER



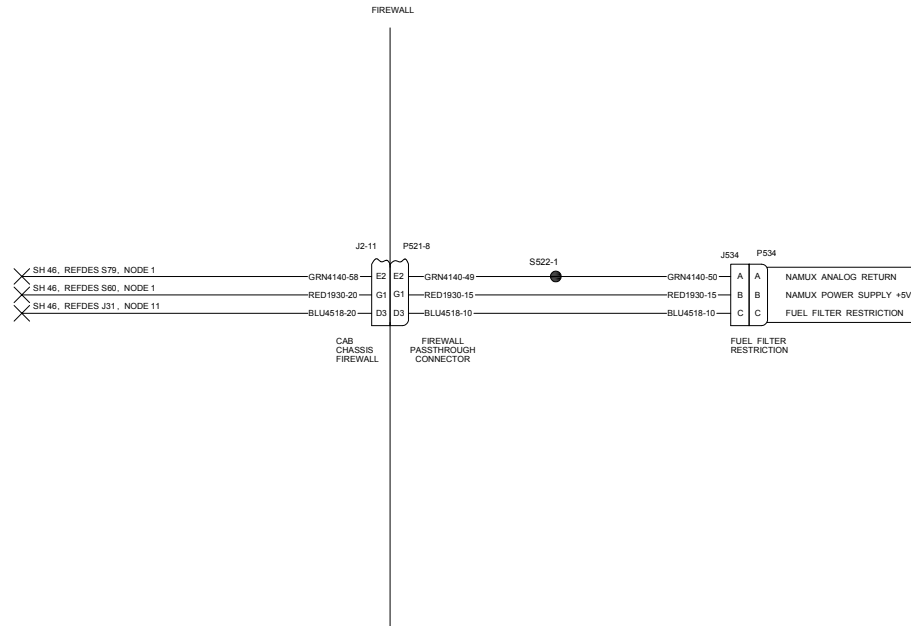

FUEL FILTER RESTRICTION

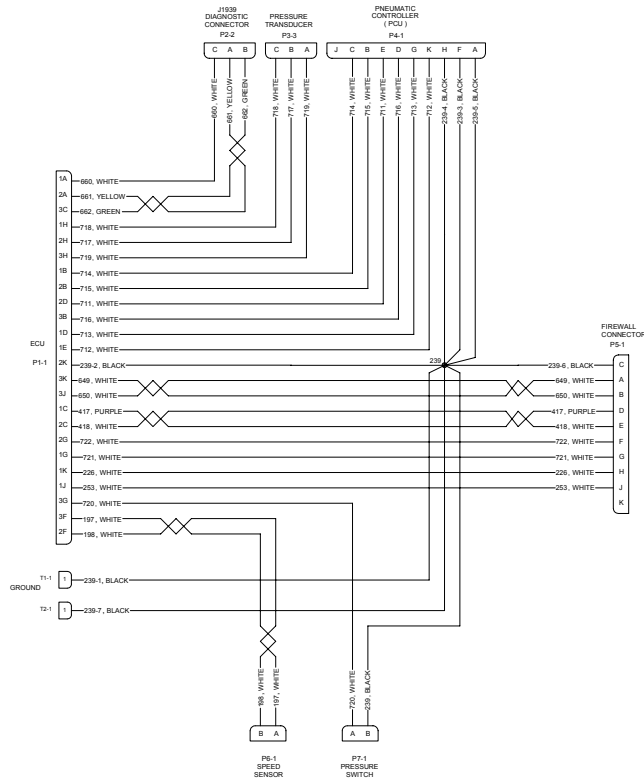

CHASSIS

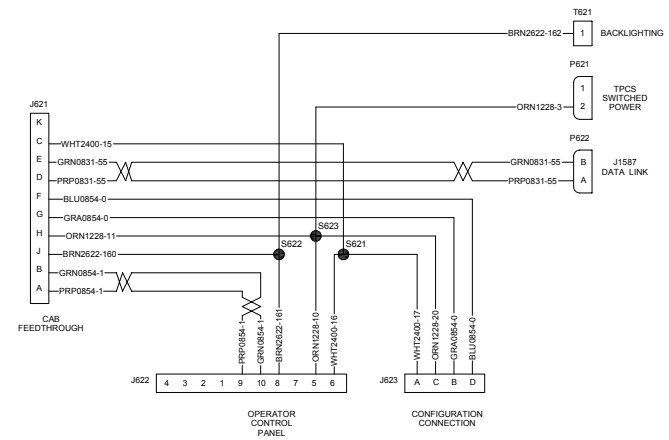

CAB

TIRE PRESSURE CONTROL SYSTEM (TPCS)
CAB & CHASSIS

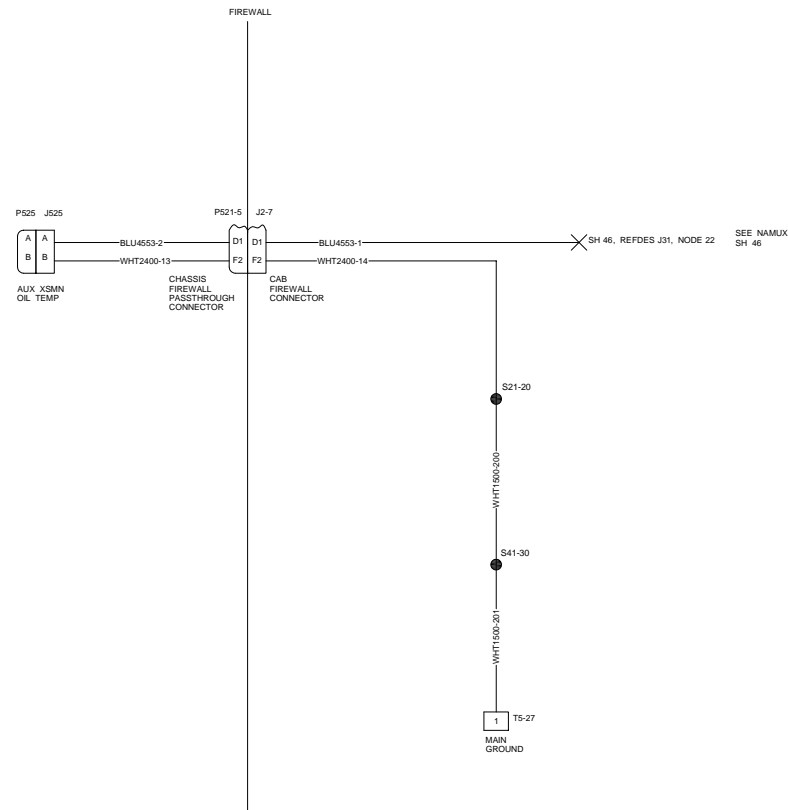

AUX TRANSMISSION OIL TEMP

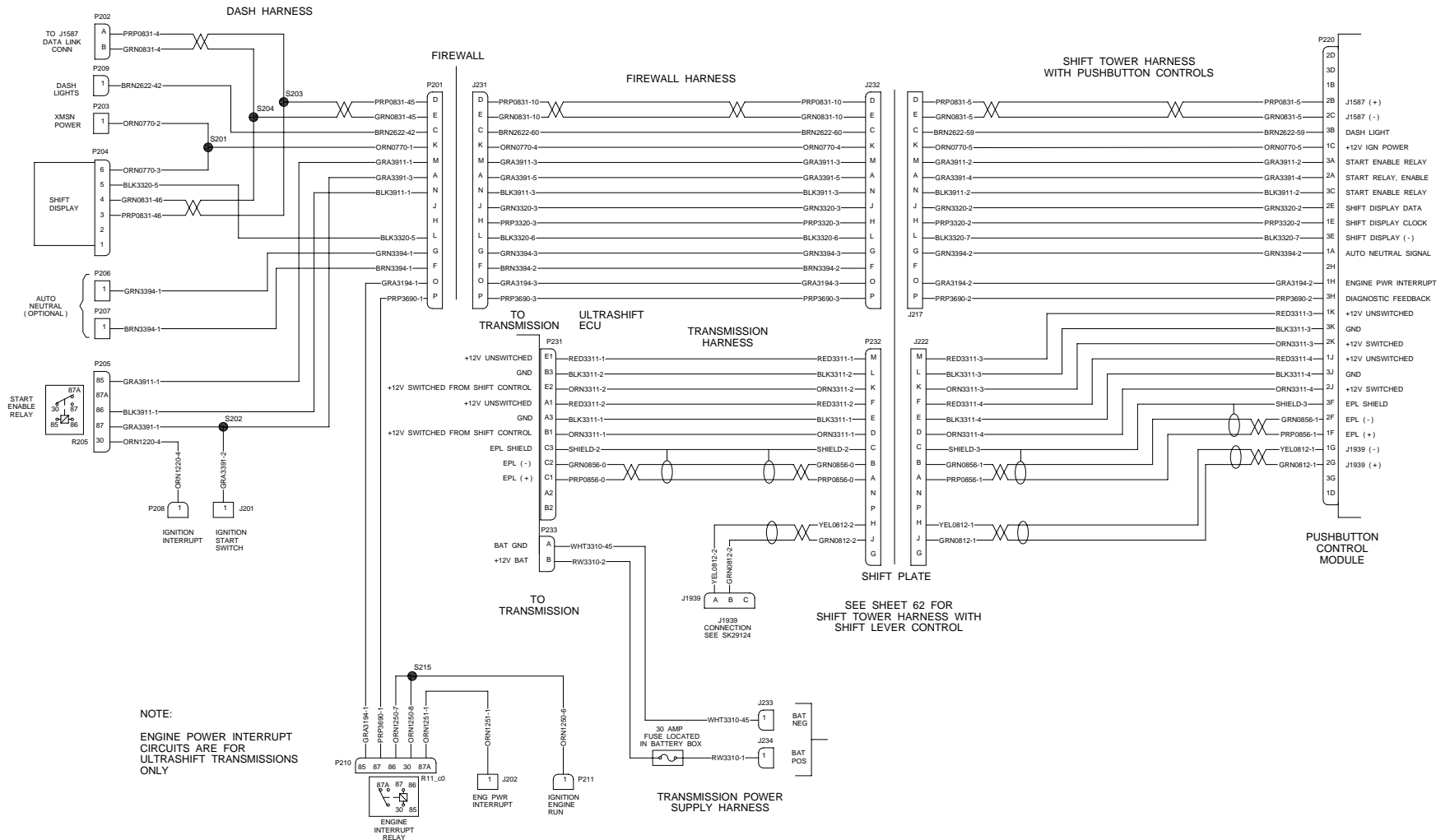

EATON ULTRASHIFT TRANSMISSION

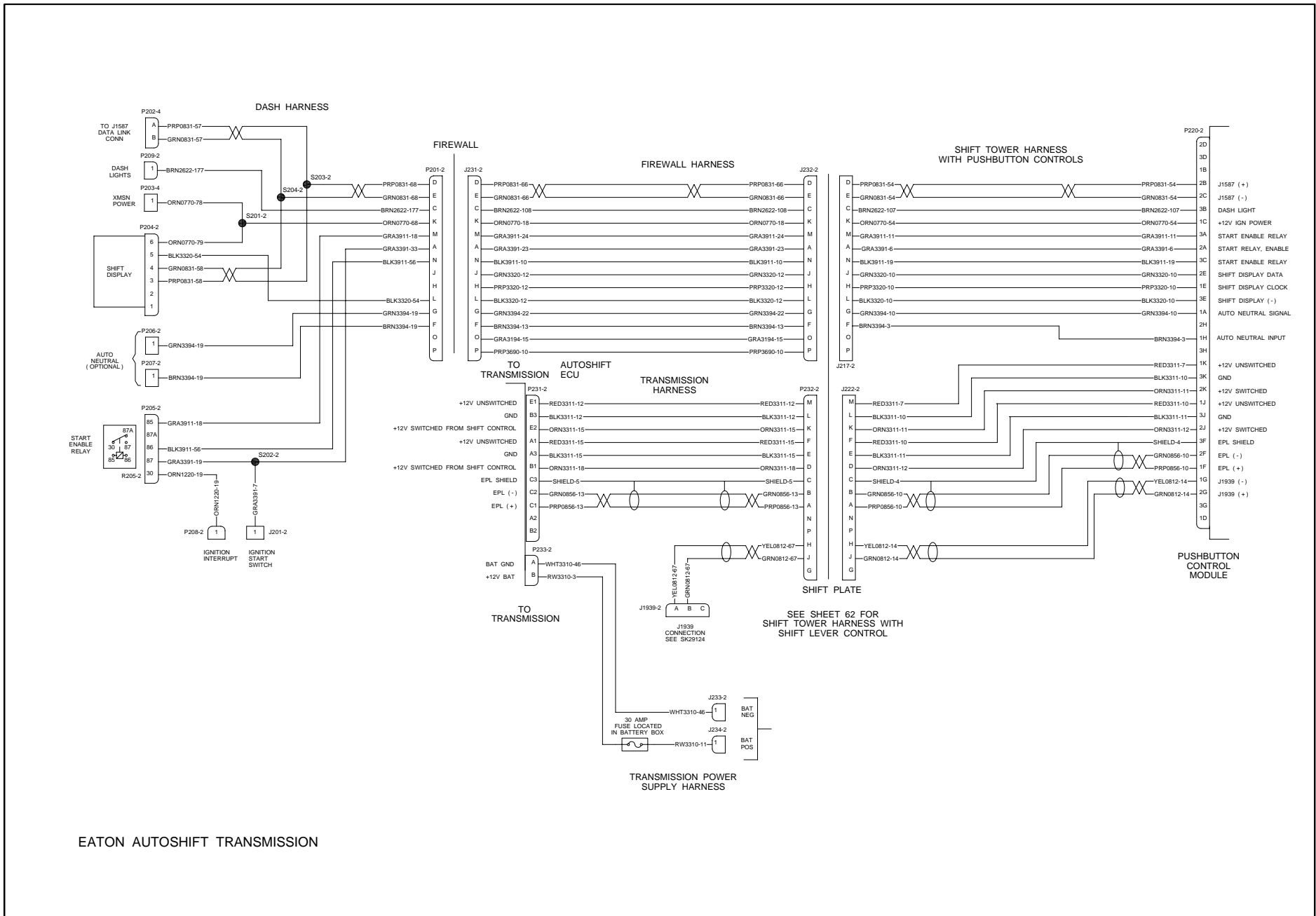

EATON AUTOSHIFT TRANSMISSION



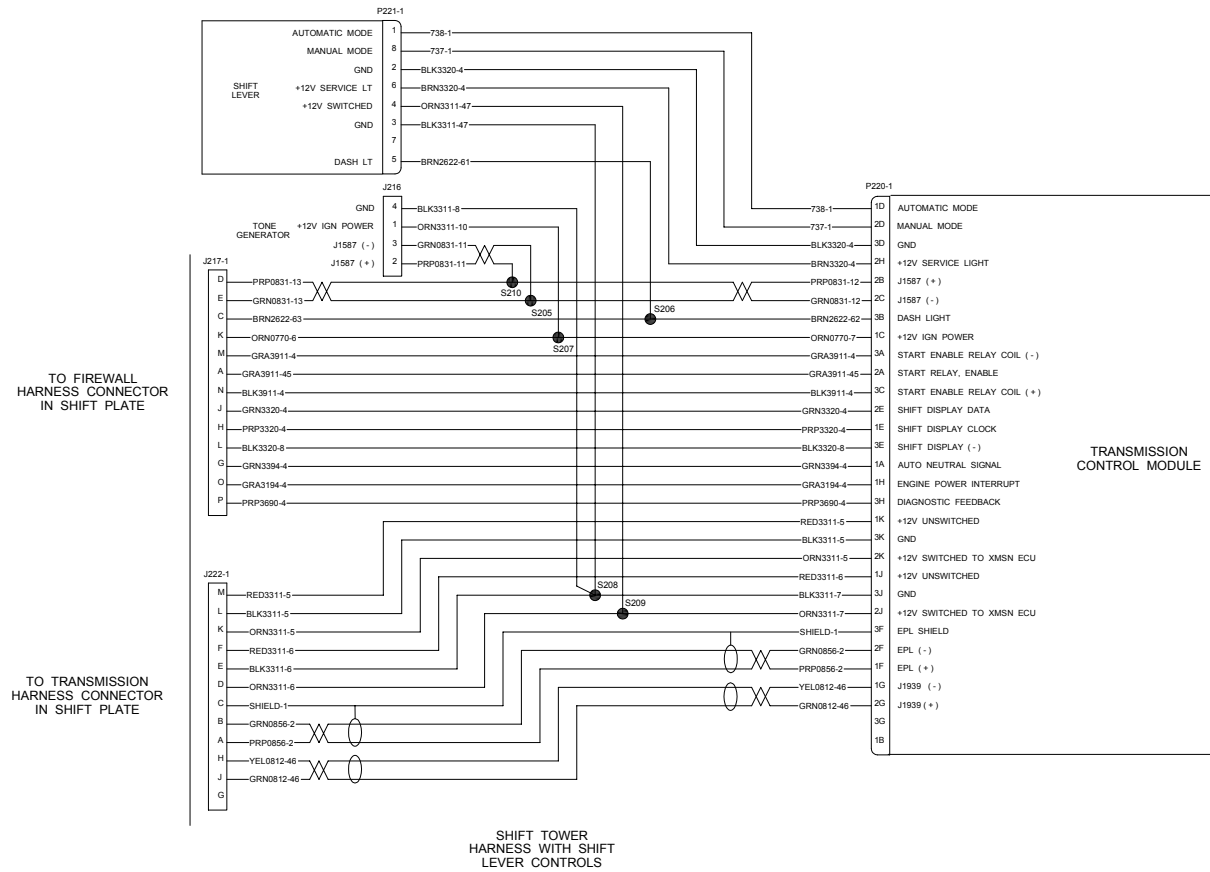

EATON AUTOSHIFT AND ULTRASHIFT TRANSMISSIONS (CONTINUED PREVIOUS SHEETS)

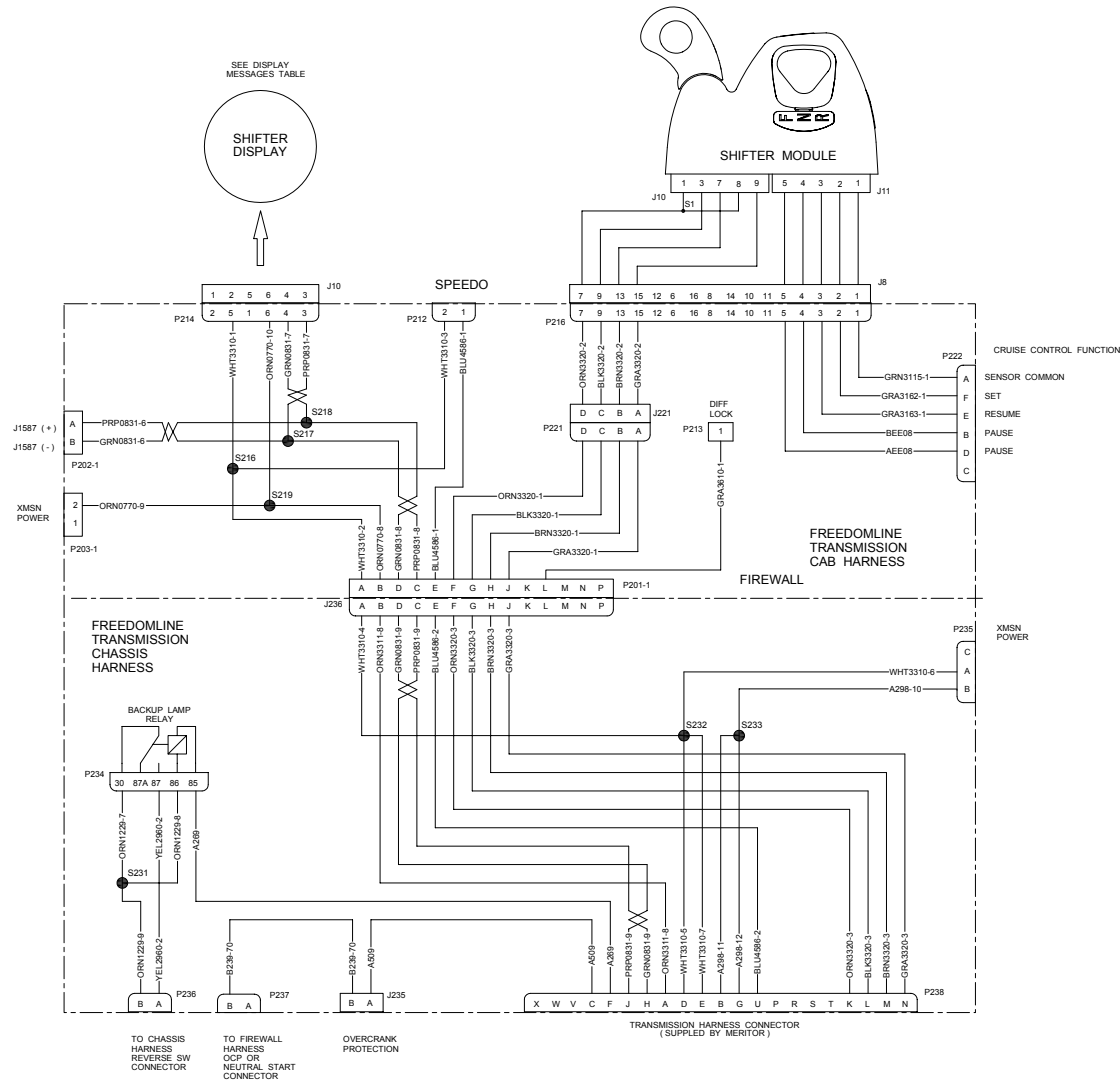

MERITOR FREEDOMLINE TRANSMISSION

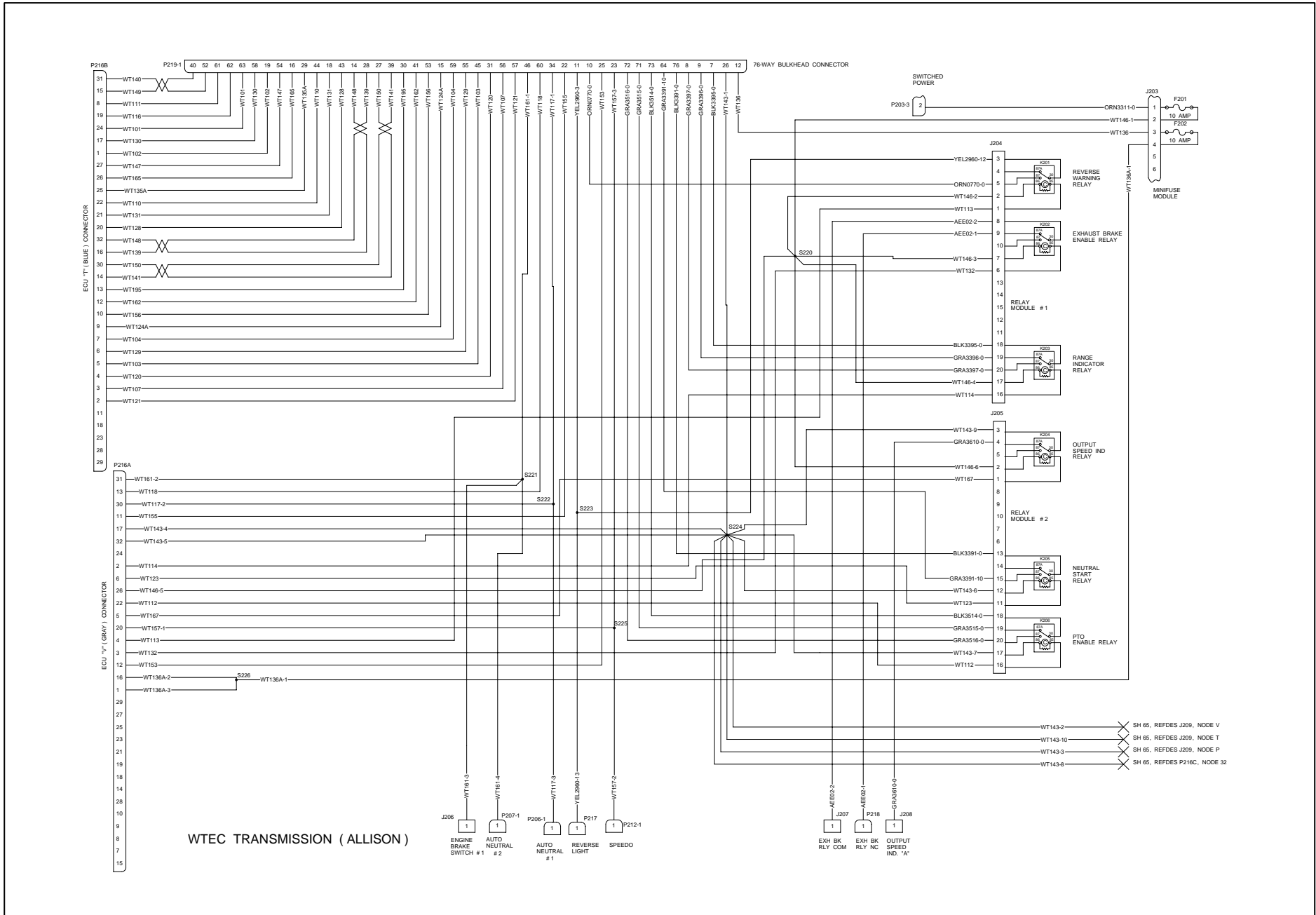

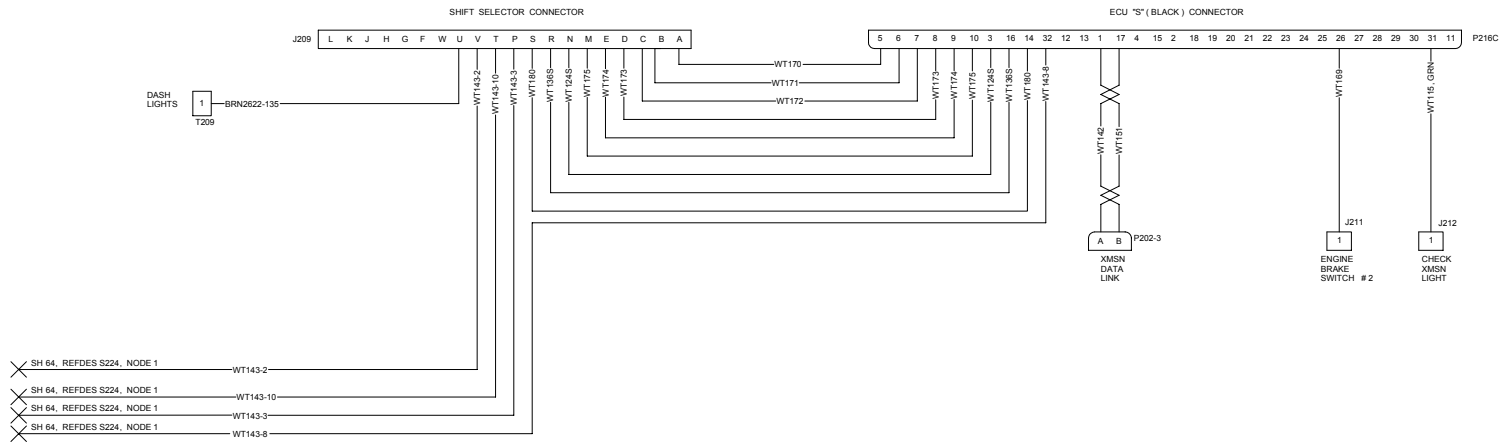

WTEC TRANSMISSION (ALLISION) (CONTINUED)

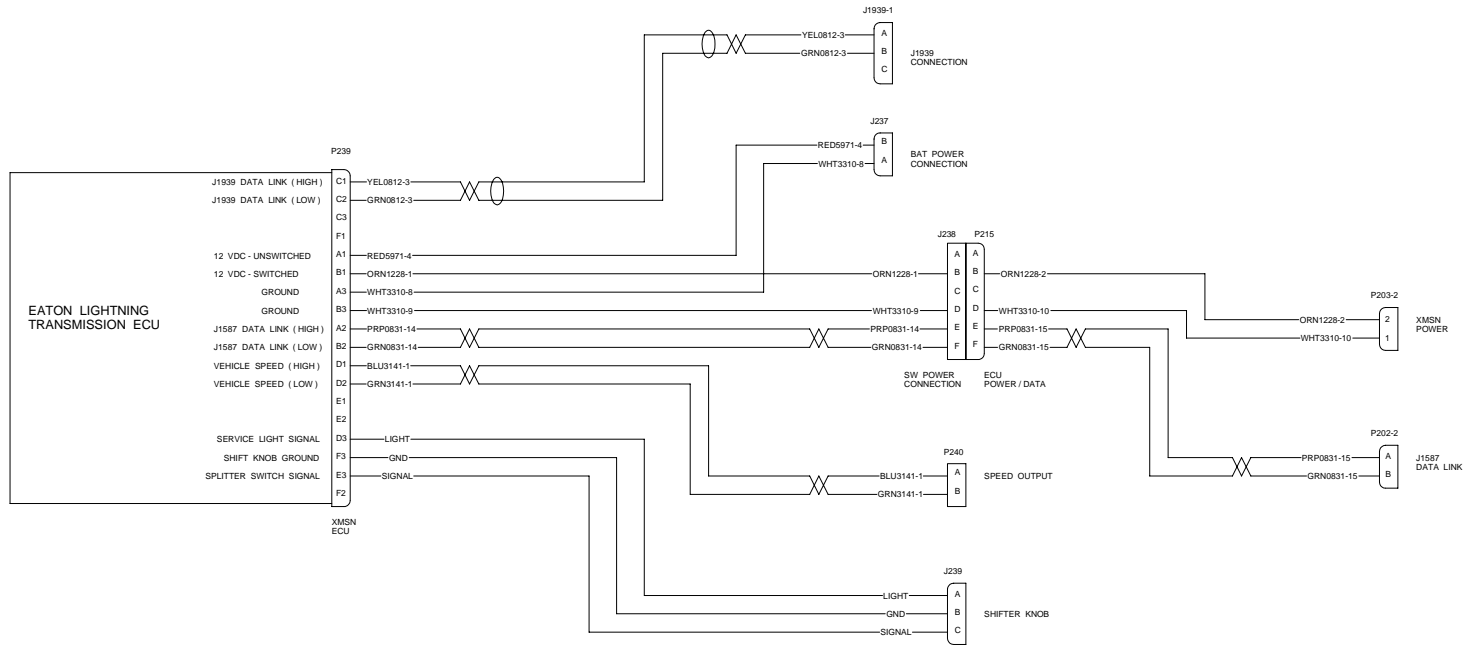

EATON LIGHTNING TRANSMISSION POWER

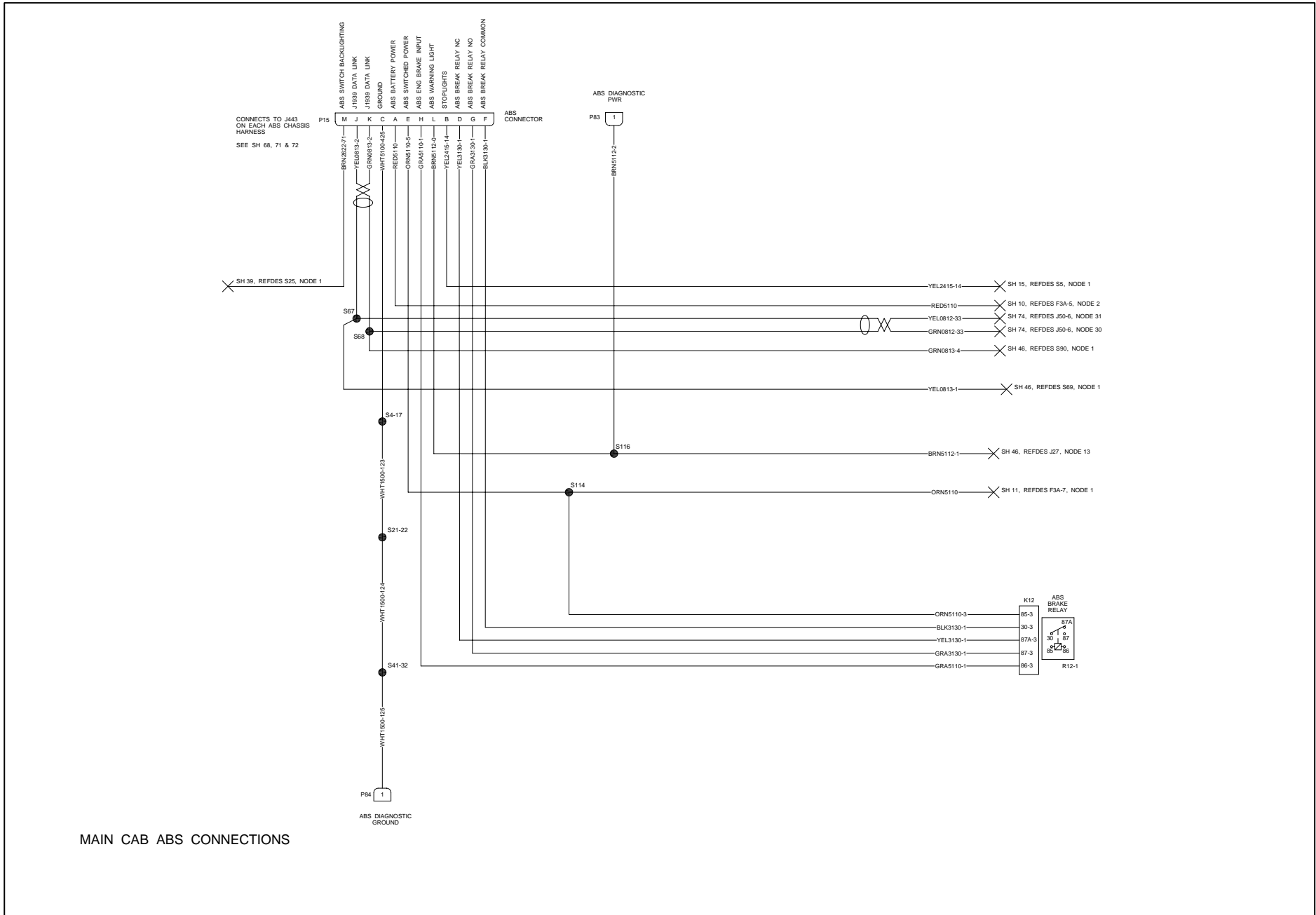

MAIN CAB ABS CONNECTIONS

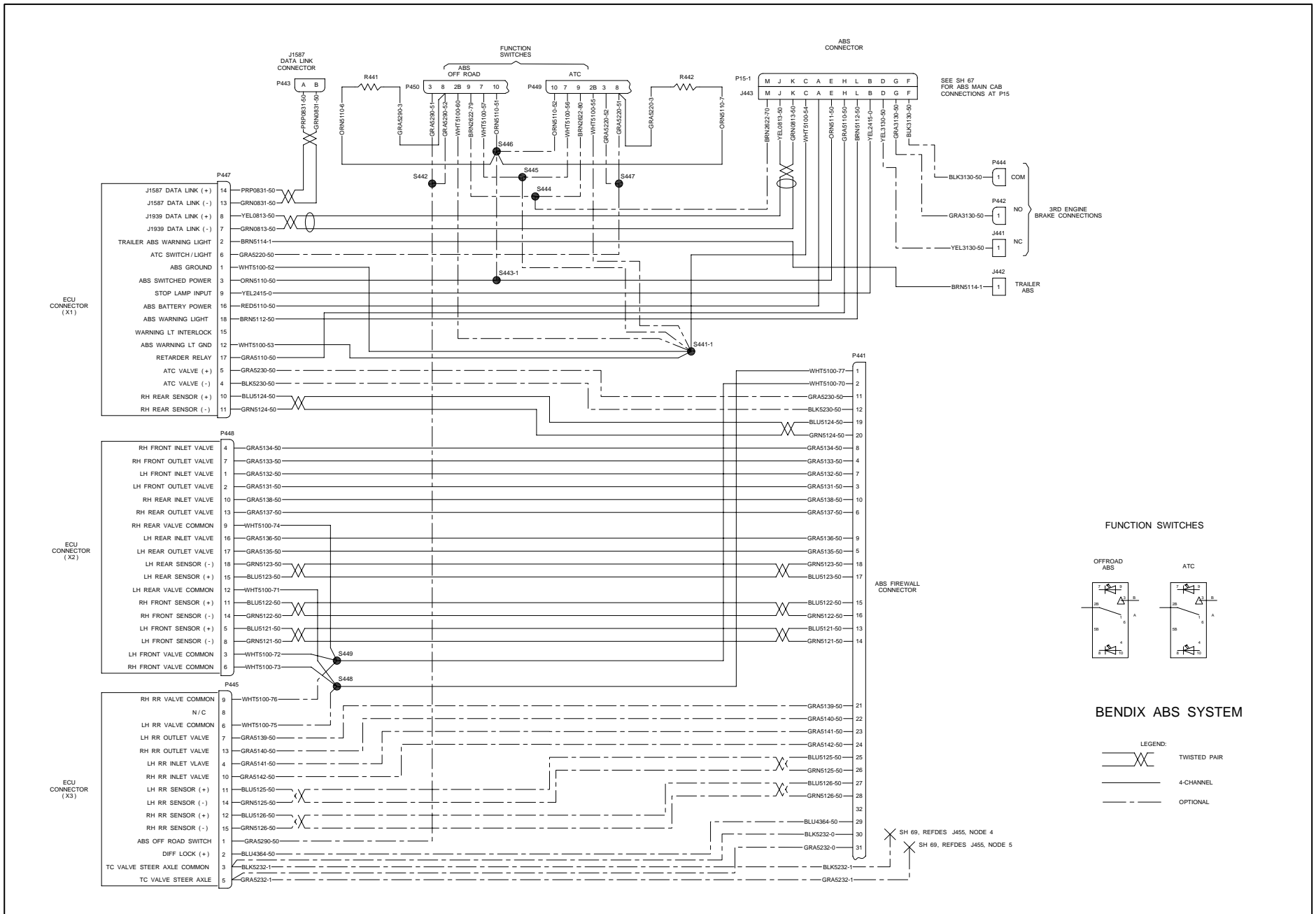

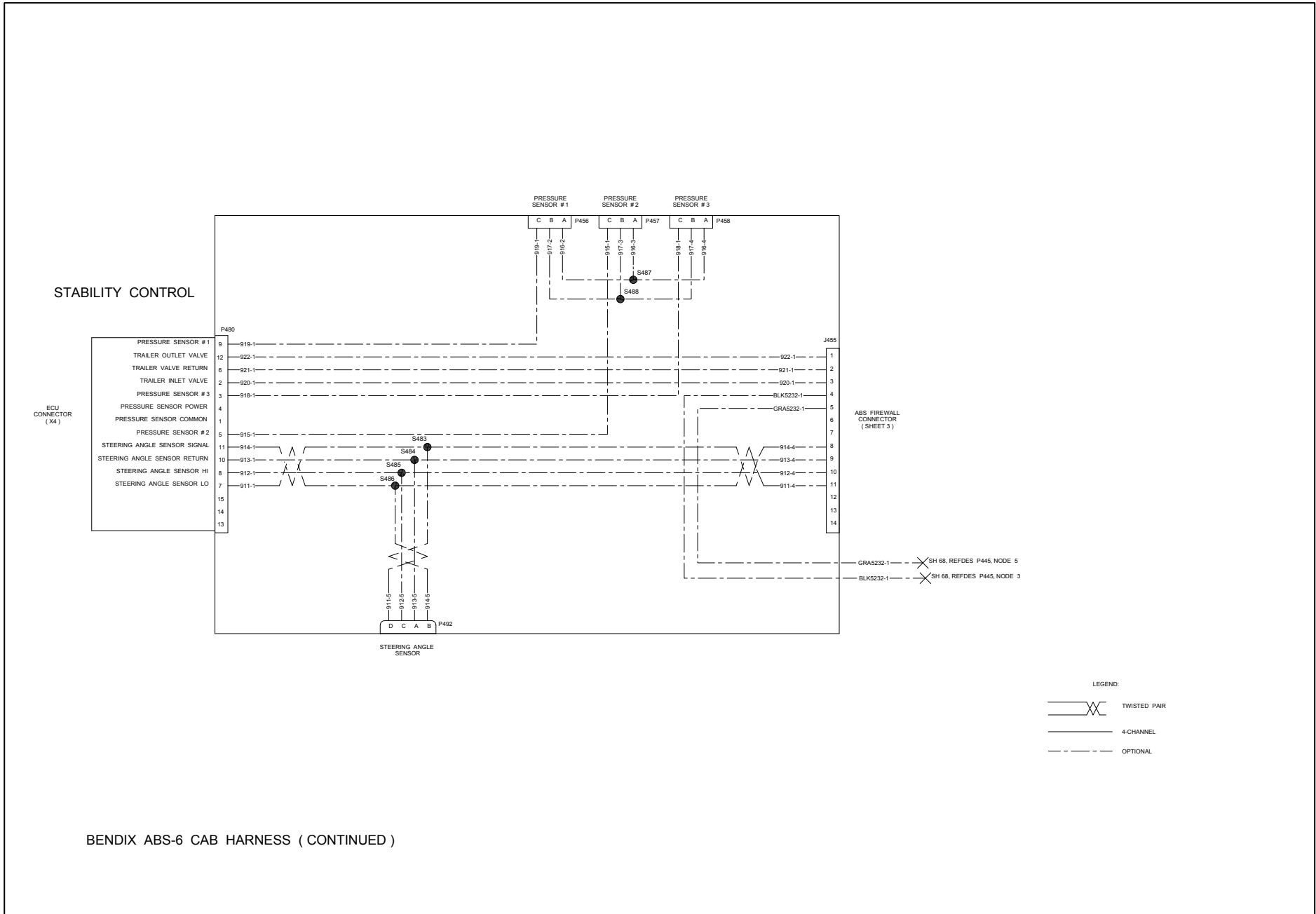

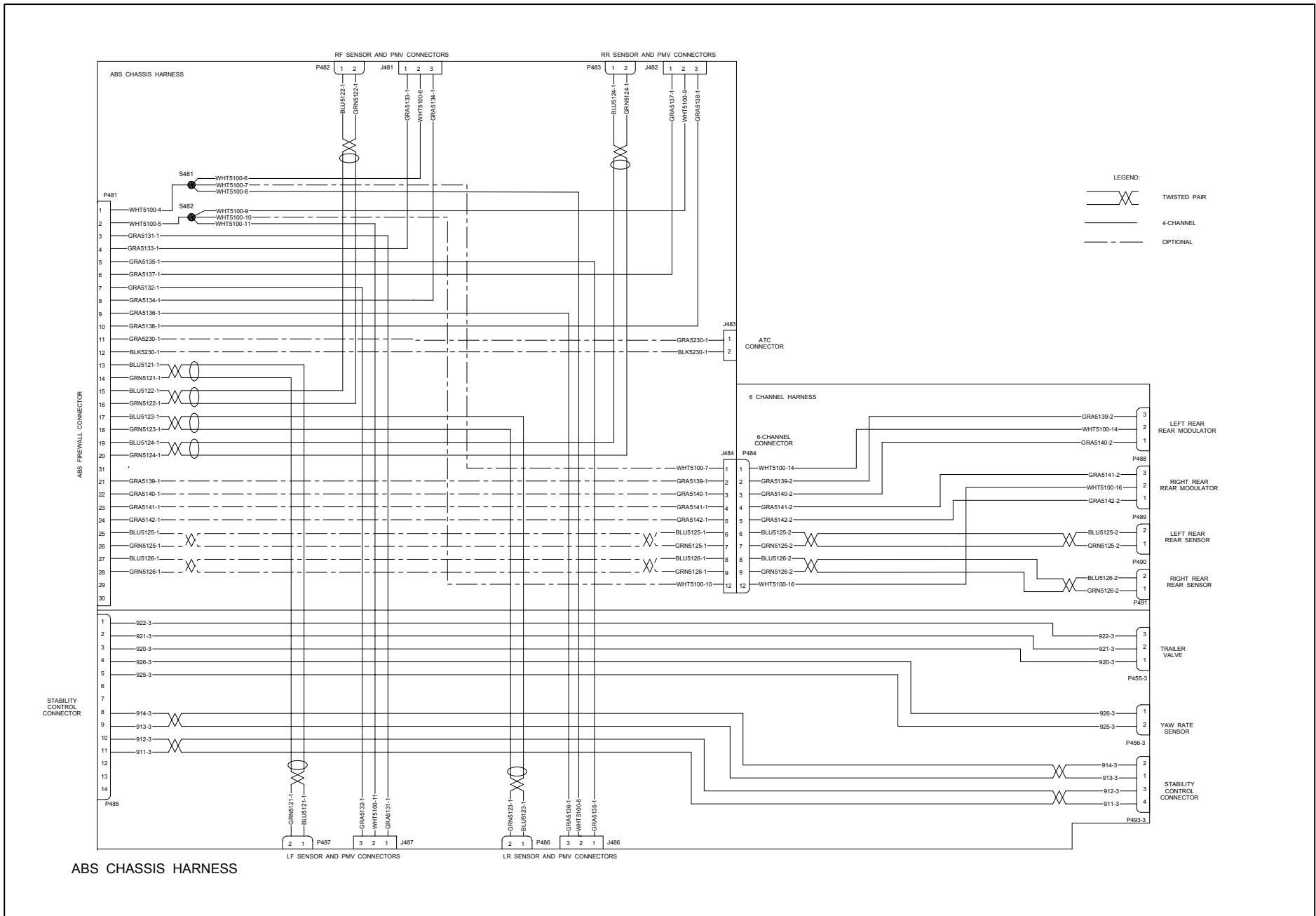

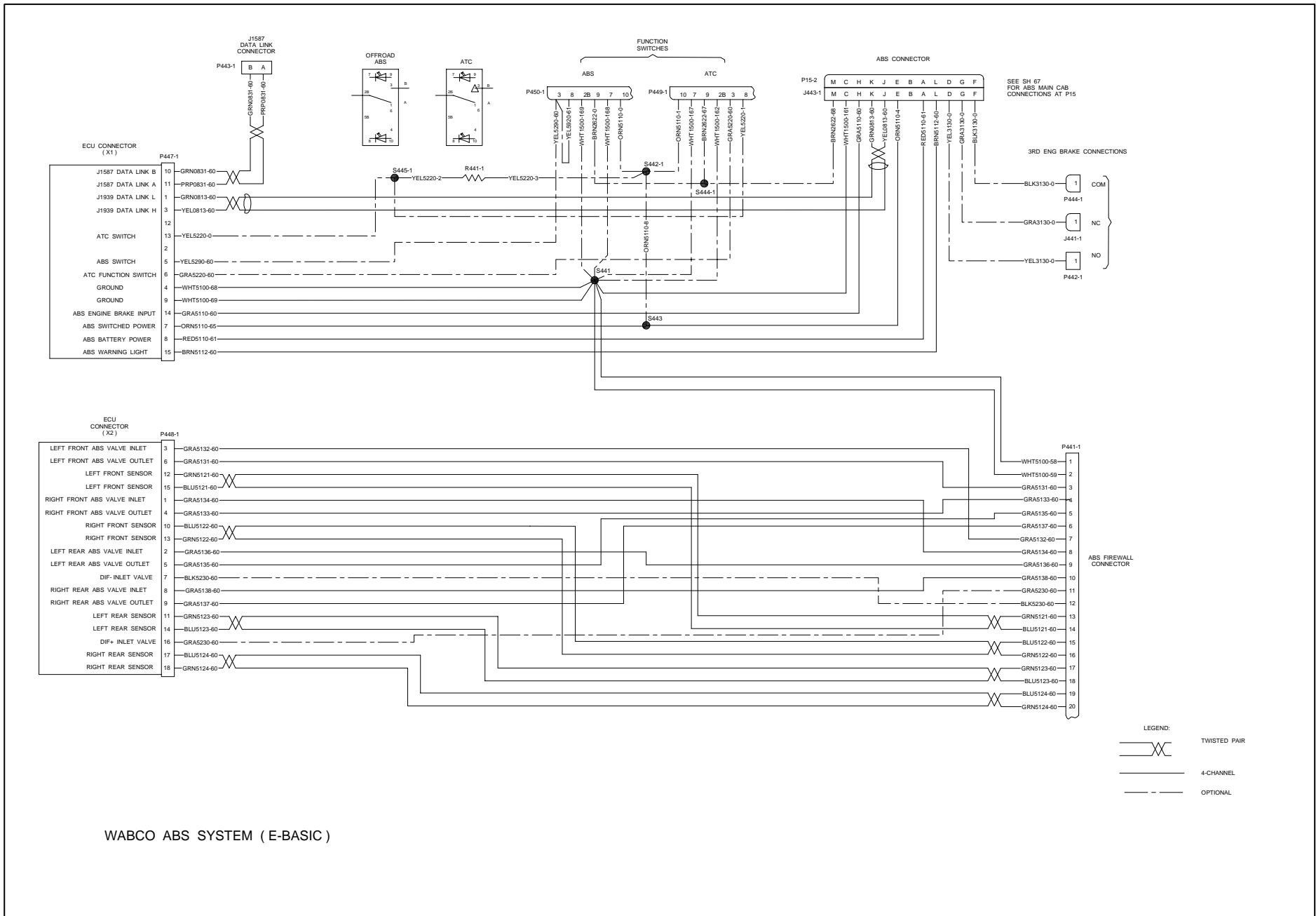

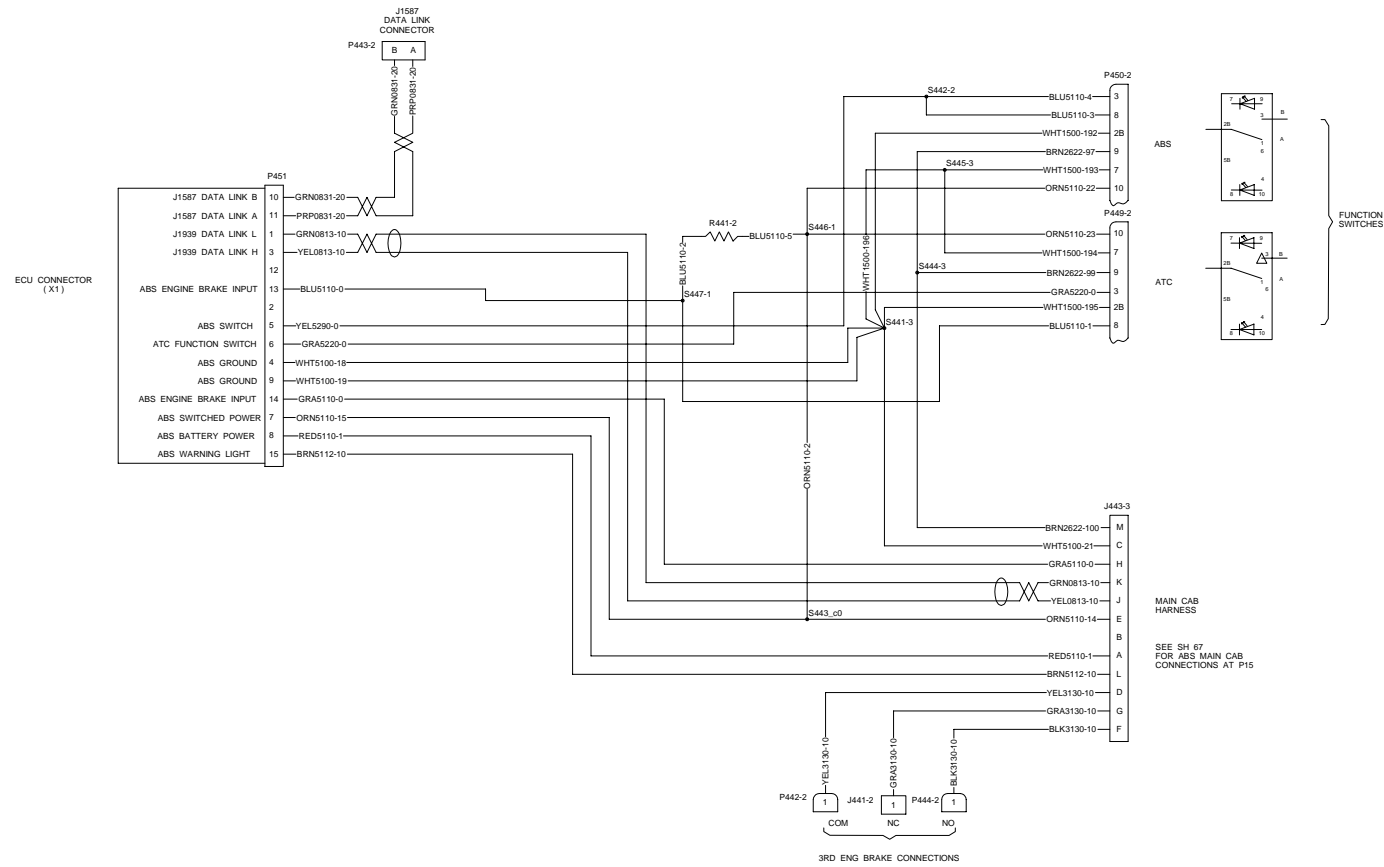

WABCO ABS SYSTEM (E-UNIVERSAL)

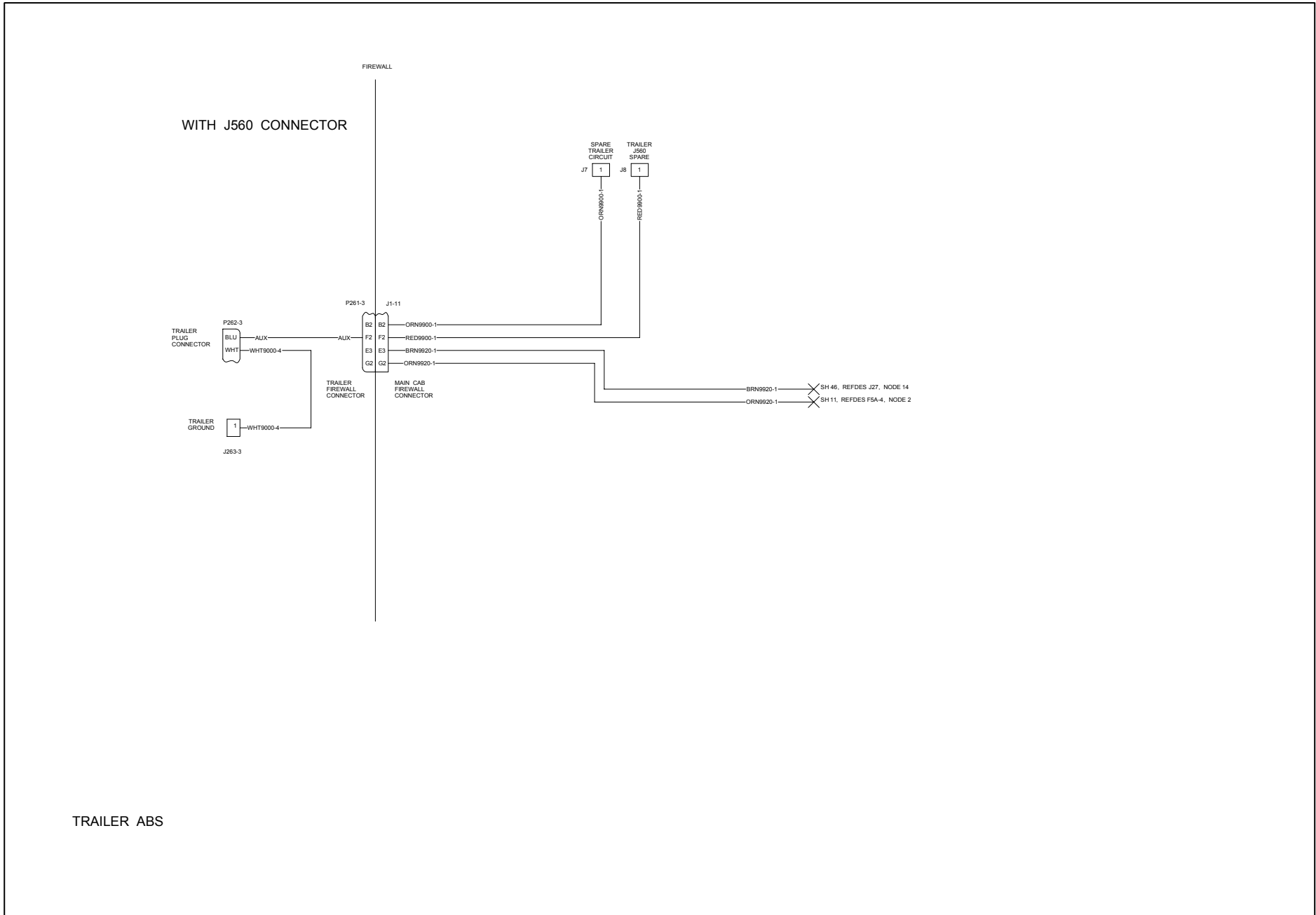

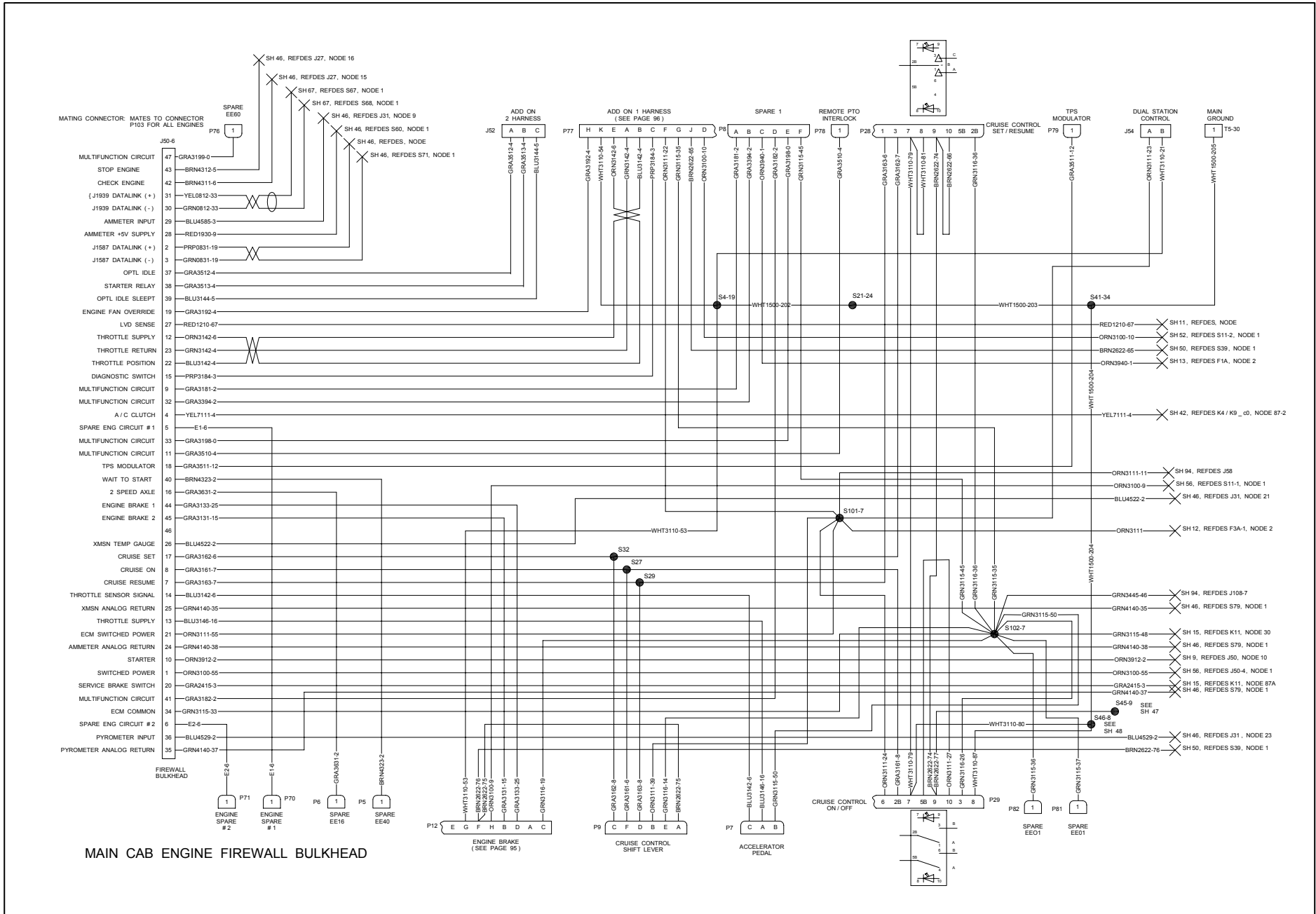

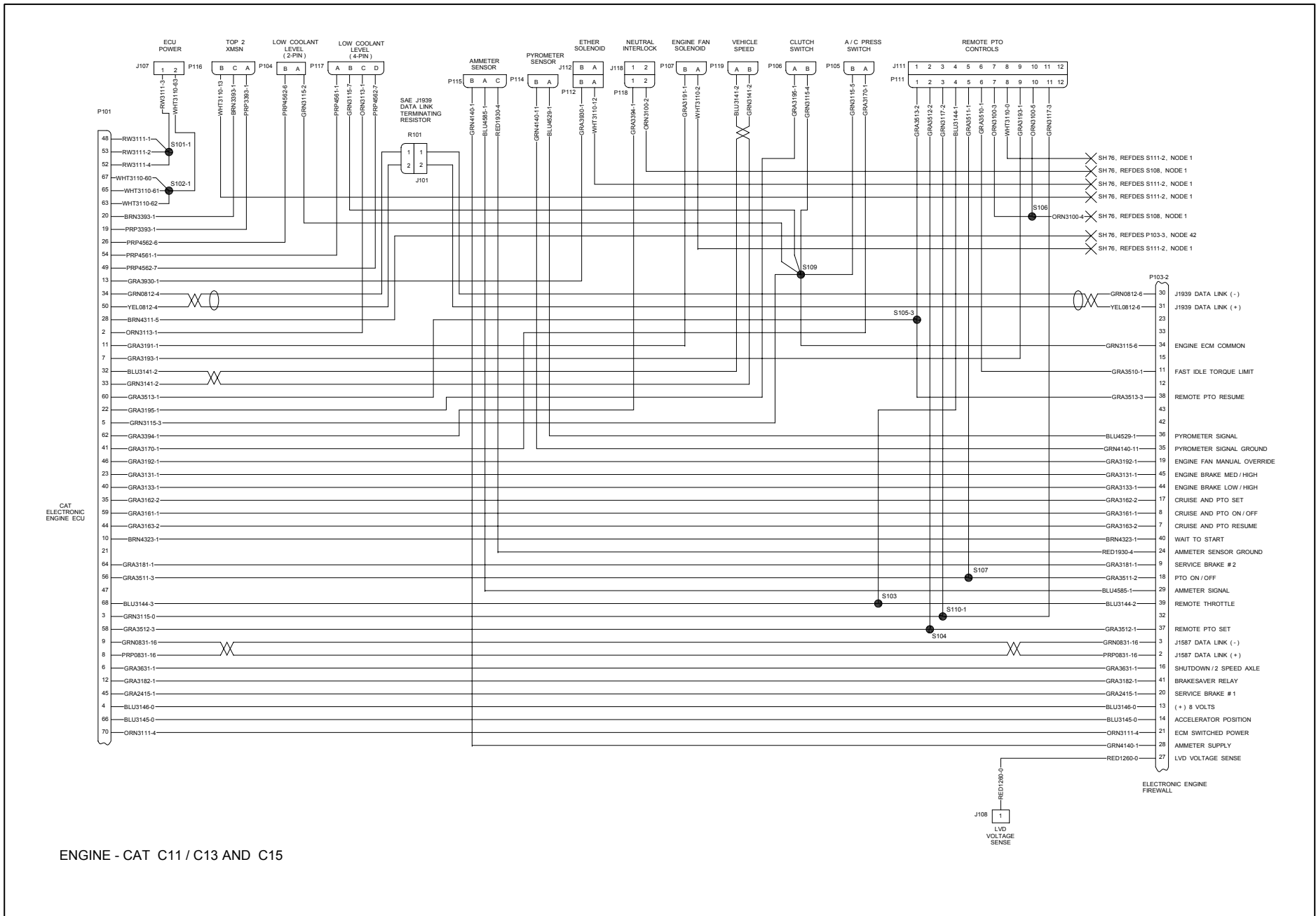

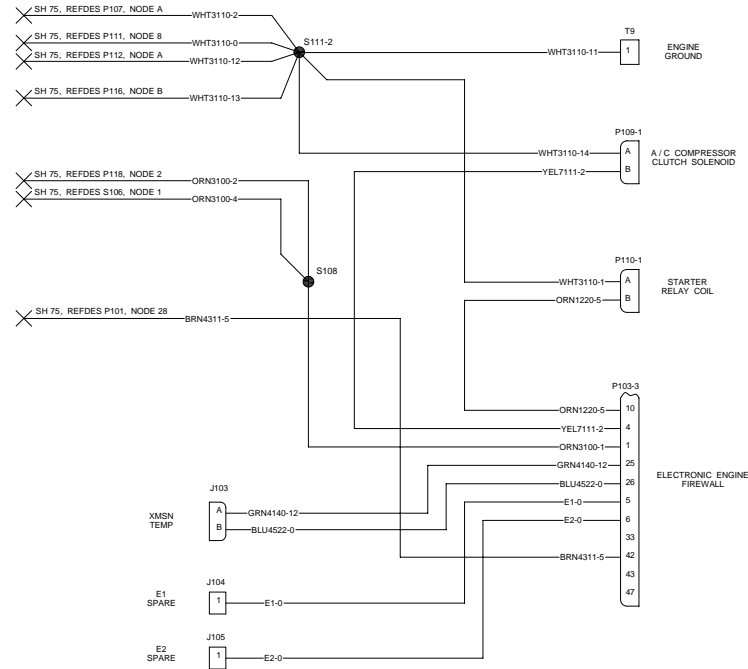

CONTINUED - CAT C11 / C13 AND C15 ENGINES

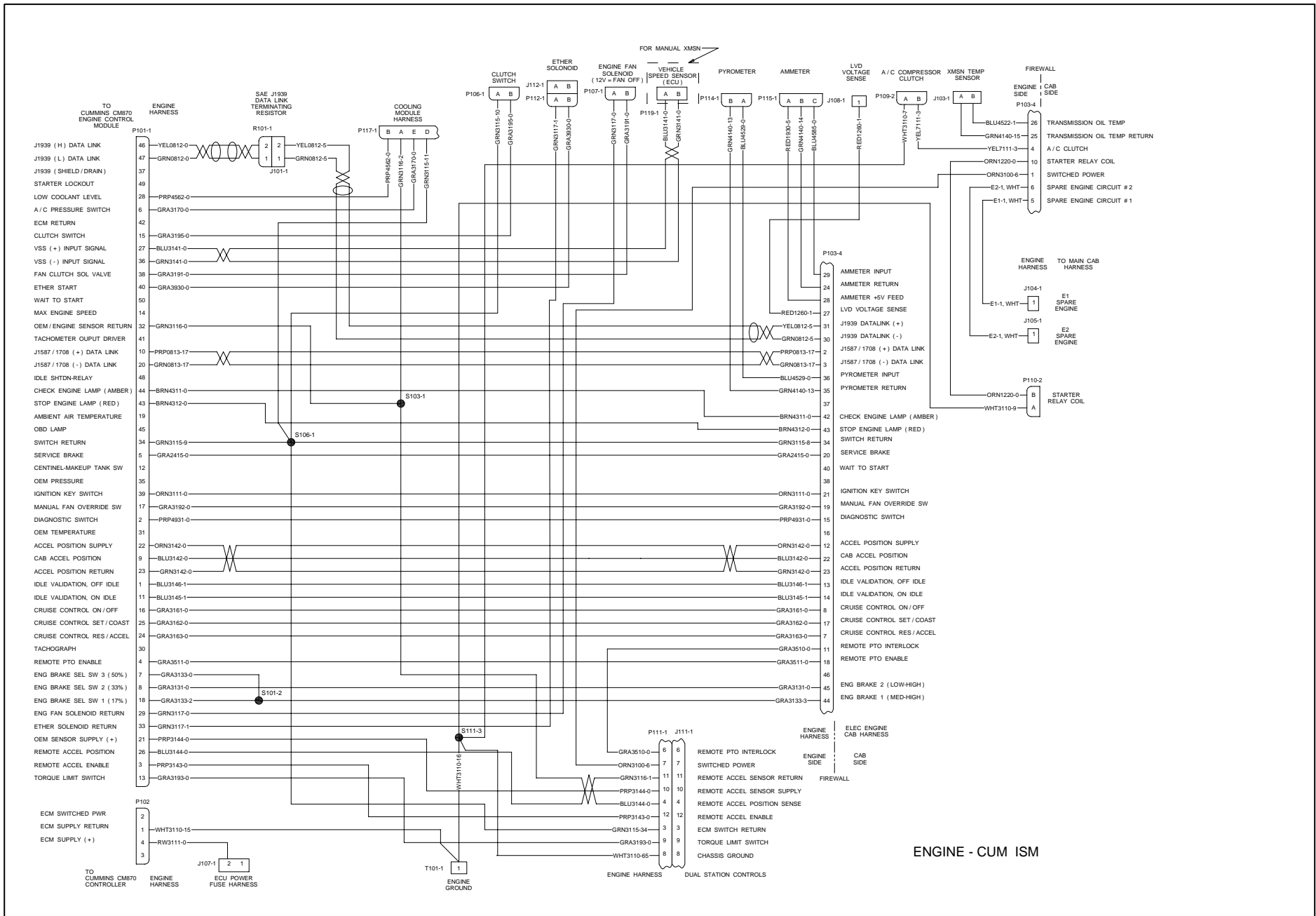

ENGINE - CUM ISM

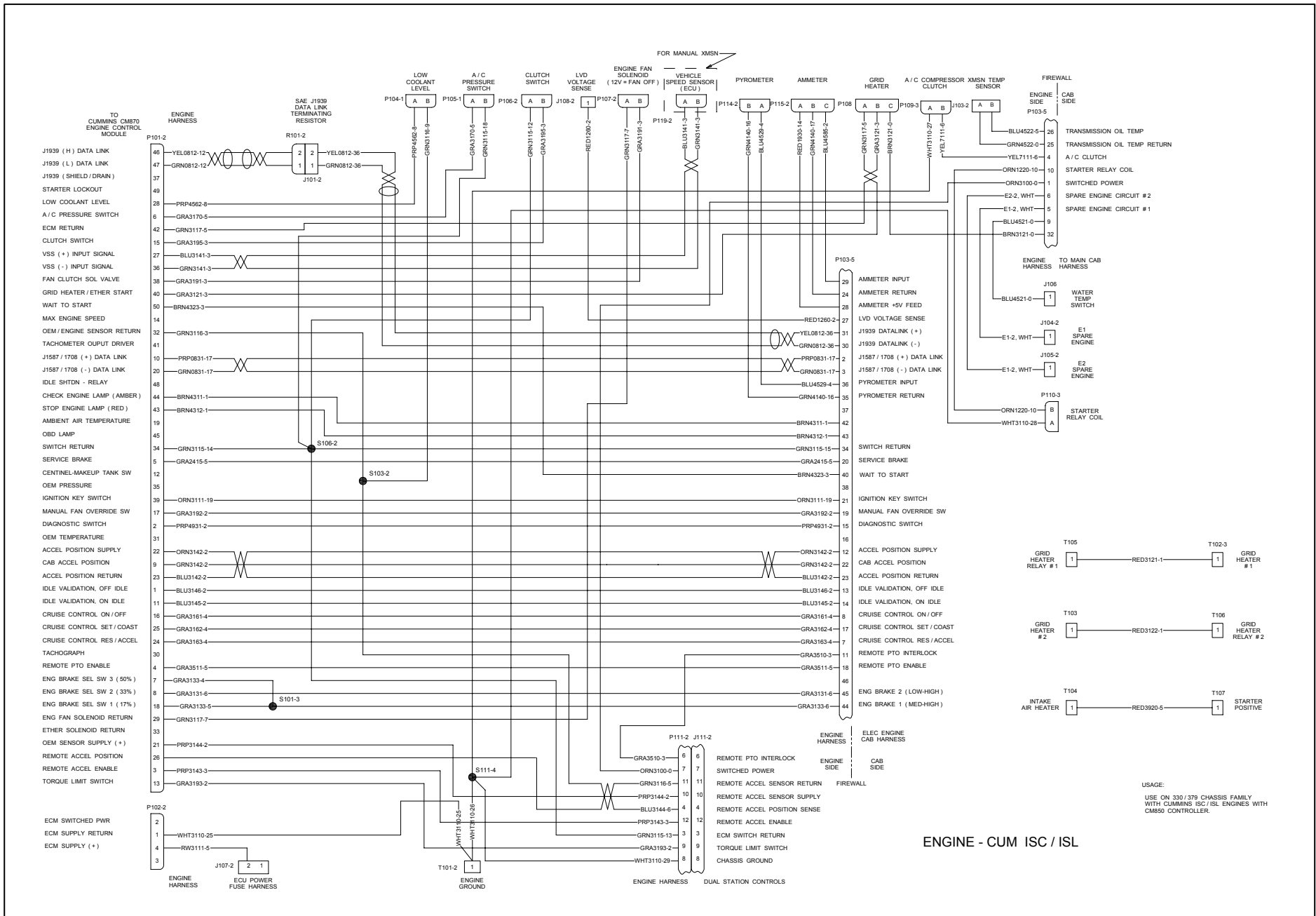

ENGINE - CUM ISC / ISL

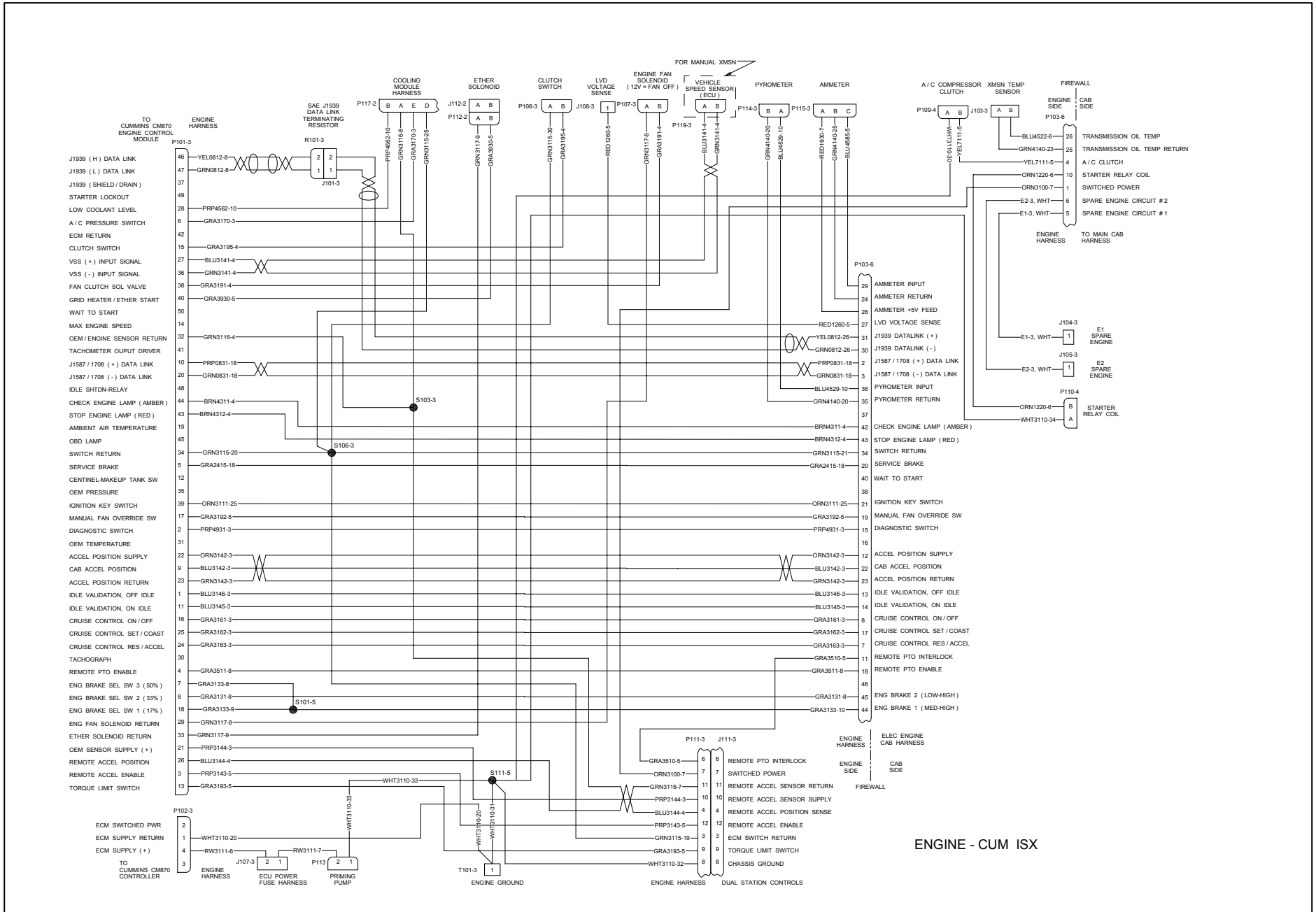

A DIVISION OF PACCAR

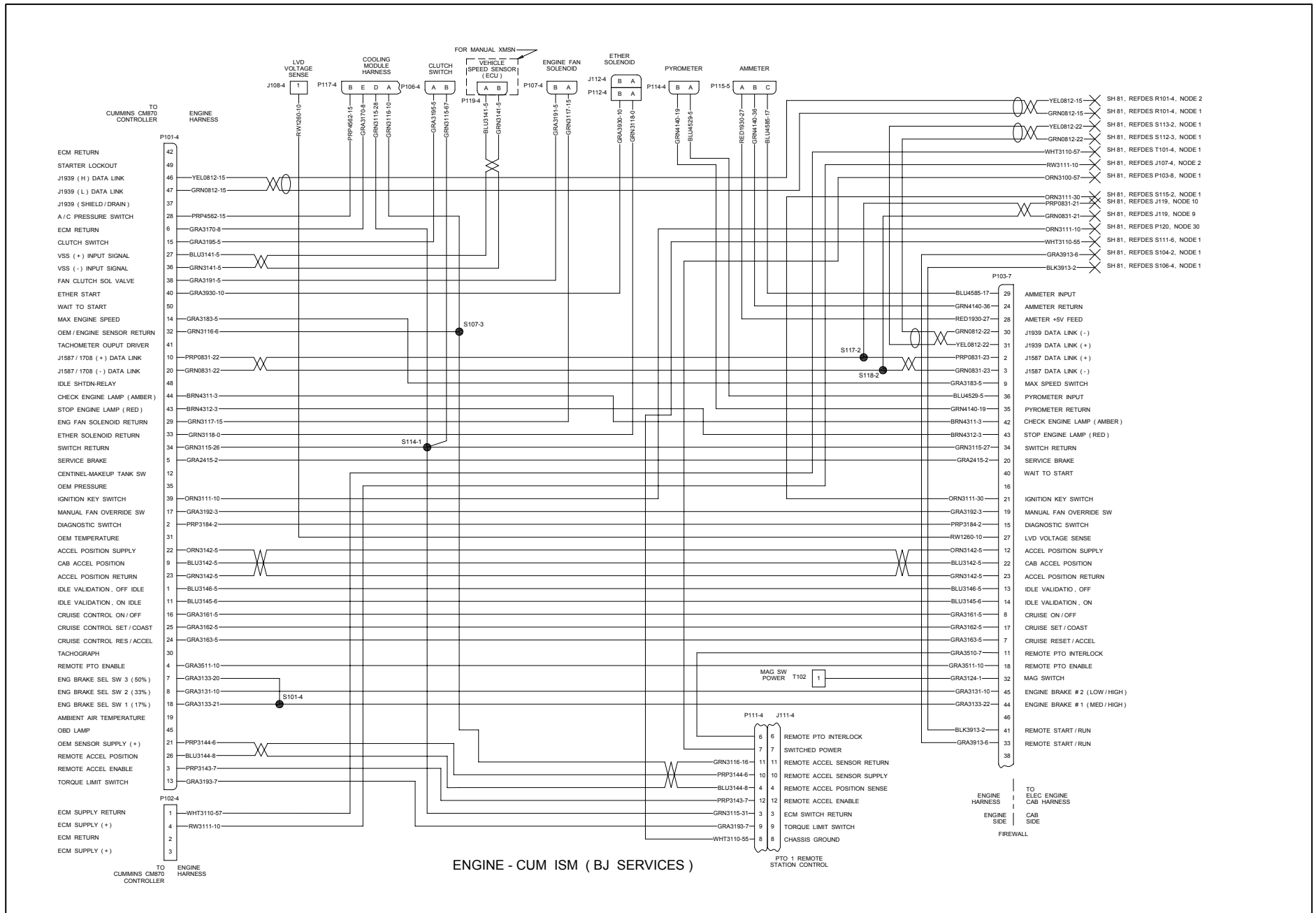

A DIVISION OF PACCAR

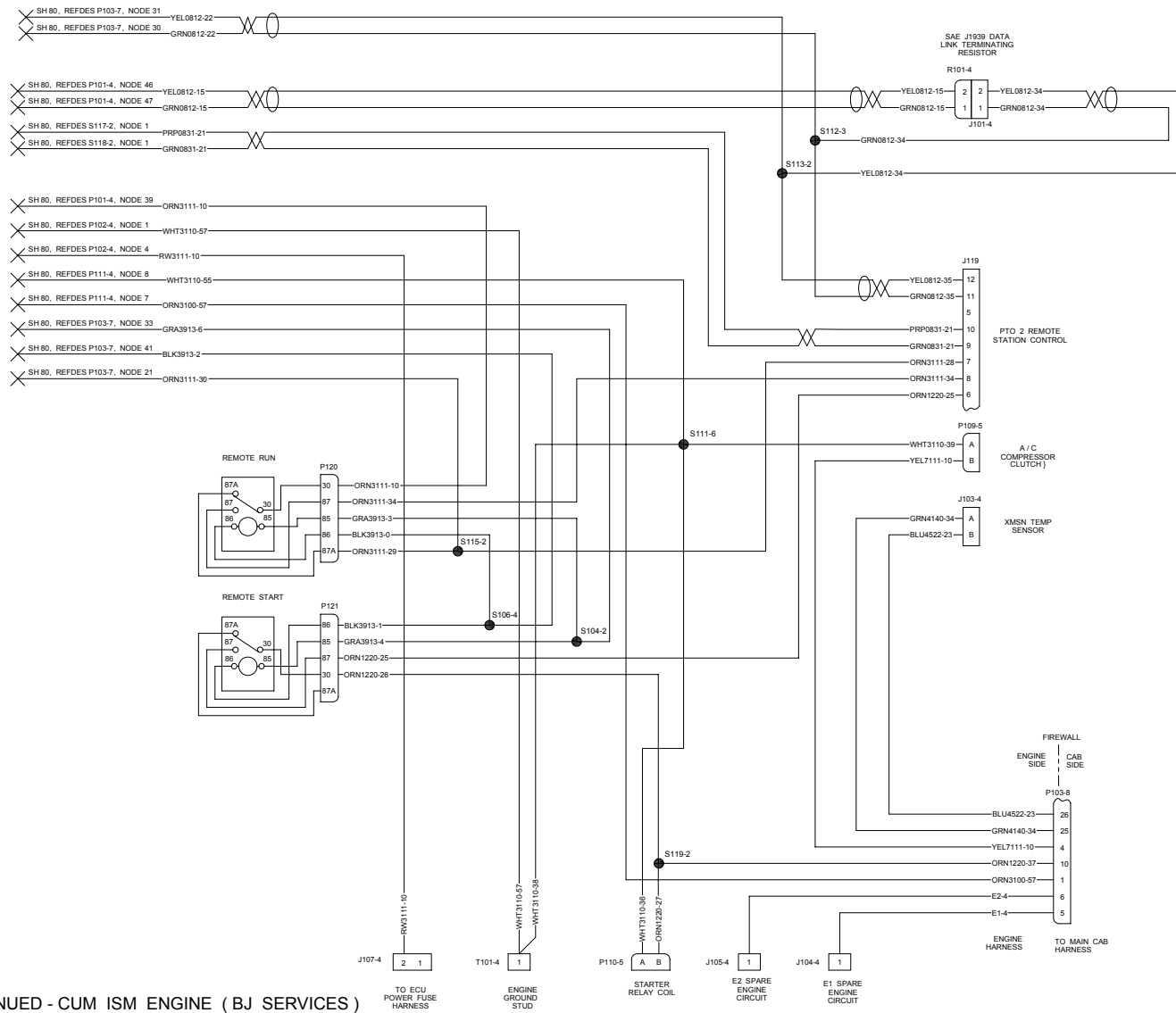

CONTINUED - CUM ISM ENGINE (BJ SERVICES)

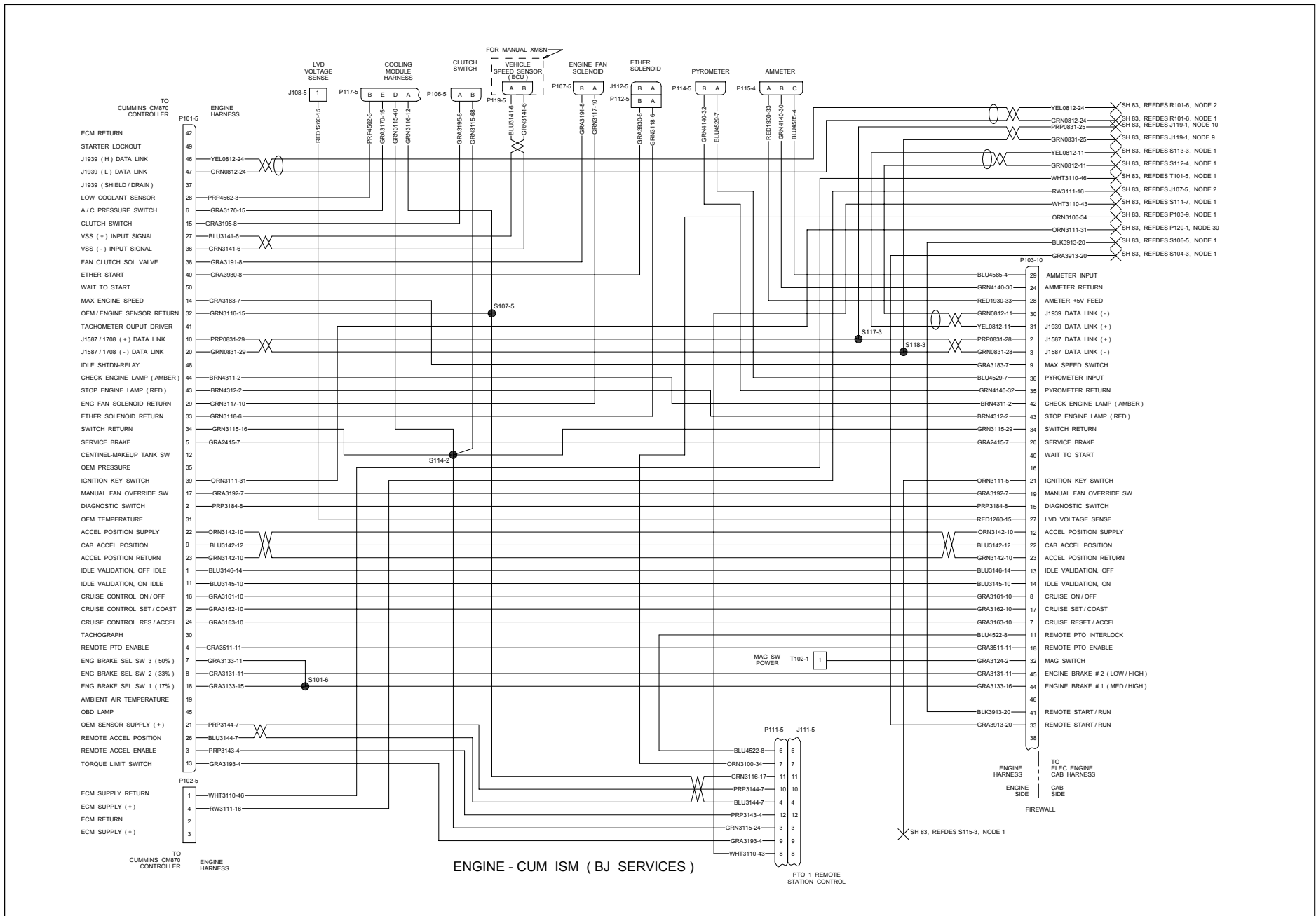

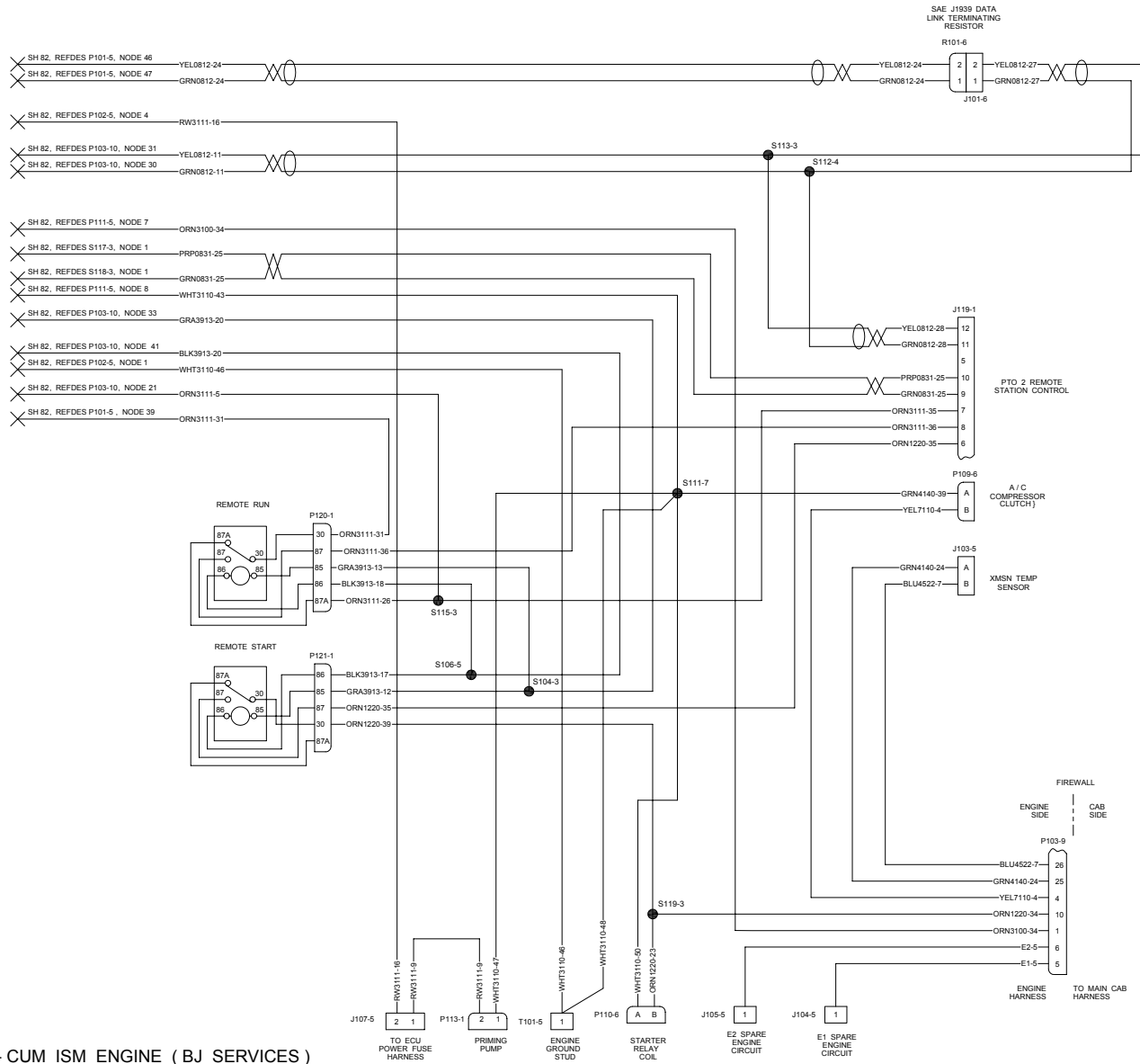

CONTINUED - CUM ISM ENGINE (BJ SERVICES)



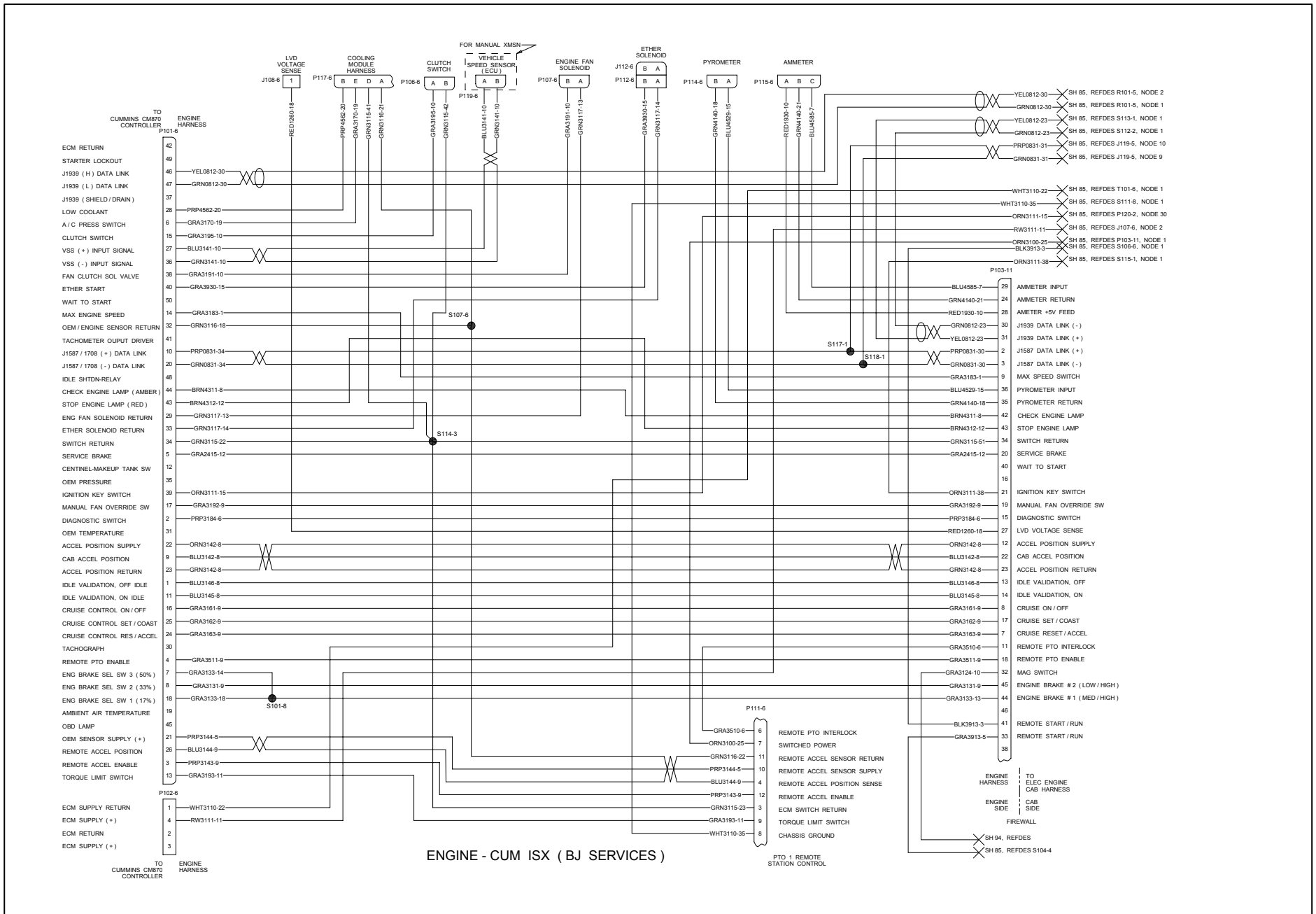

A DIVISION OF PACCAR

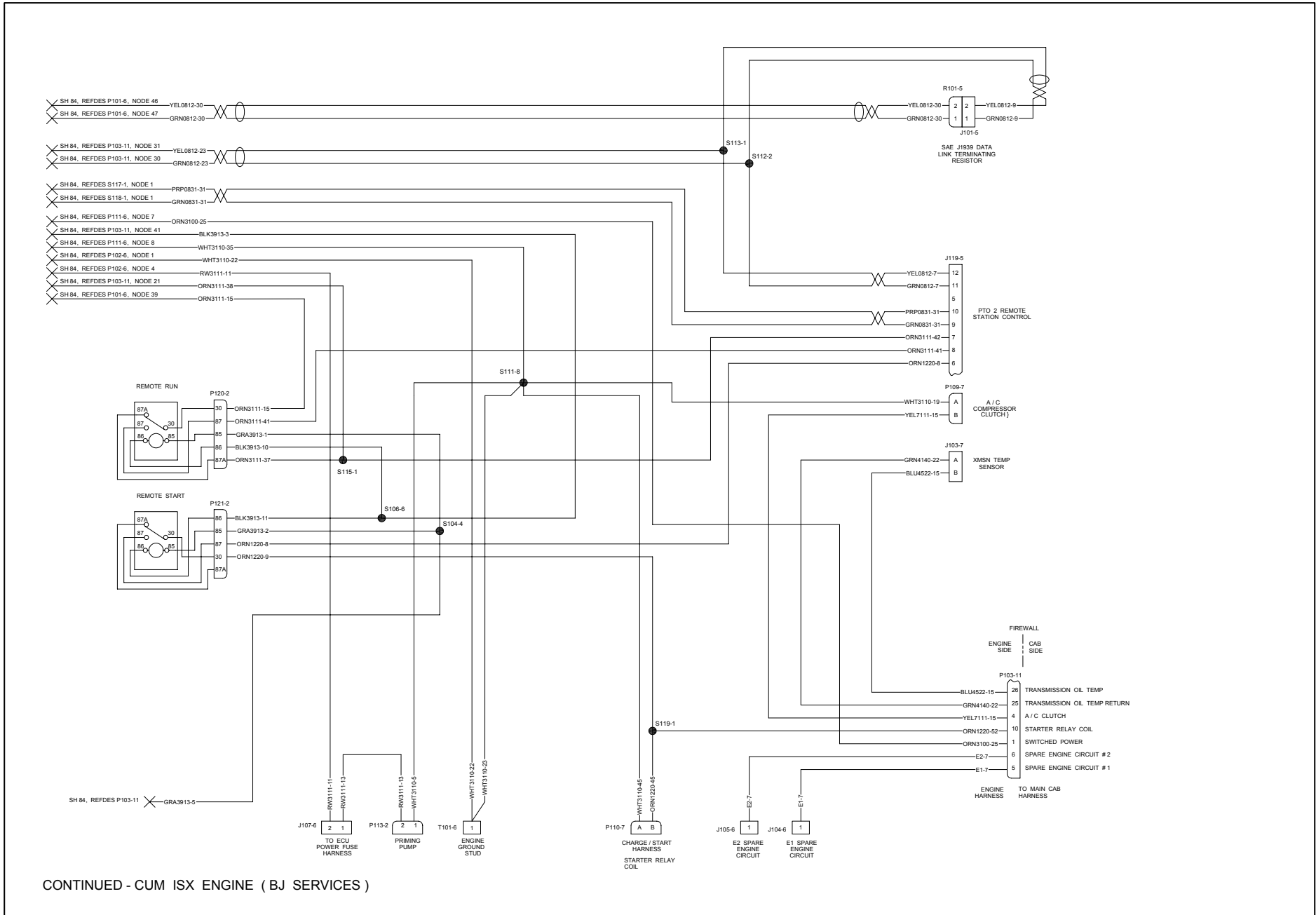

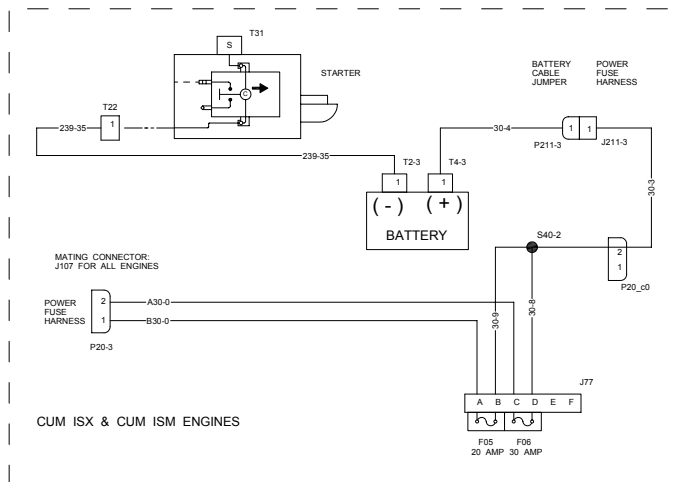
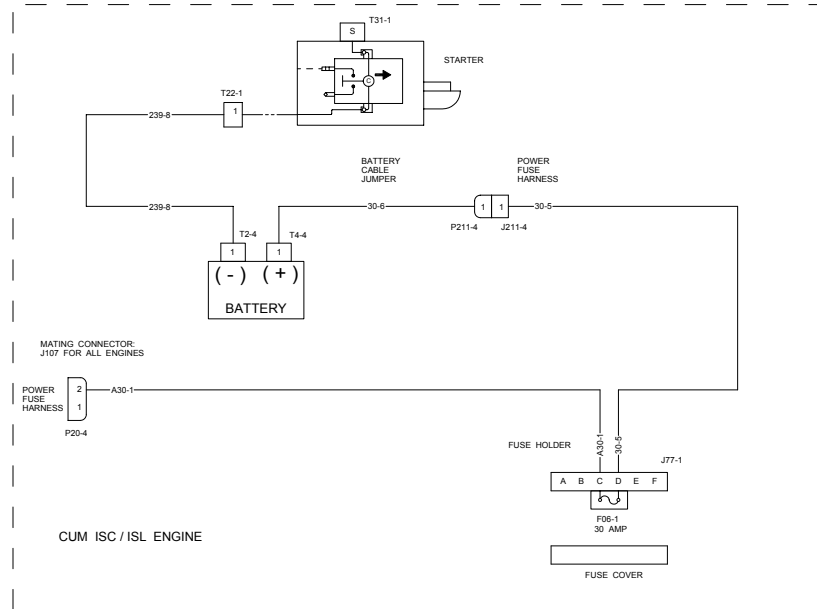
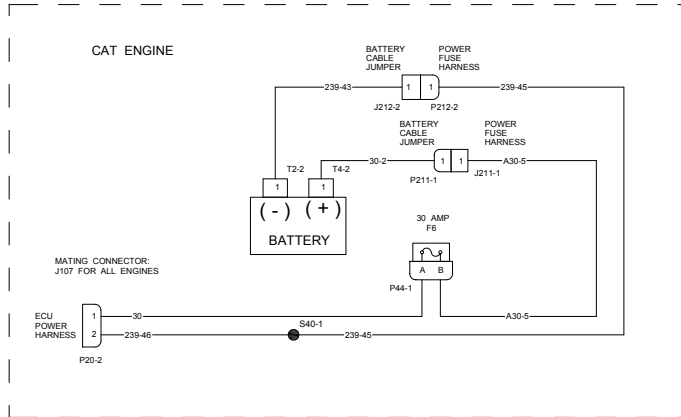

ENGINE ECU POWER

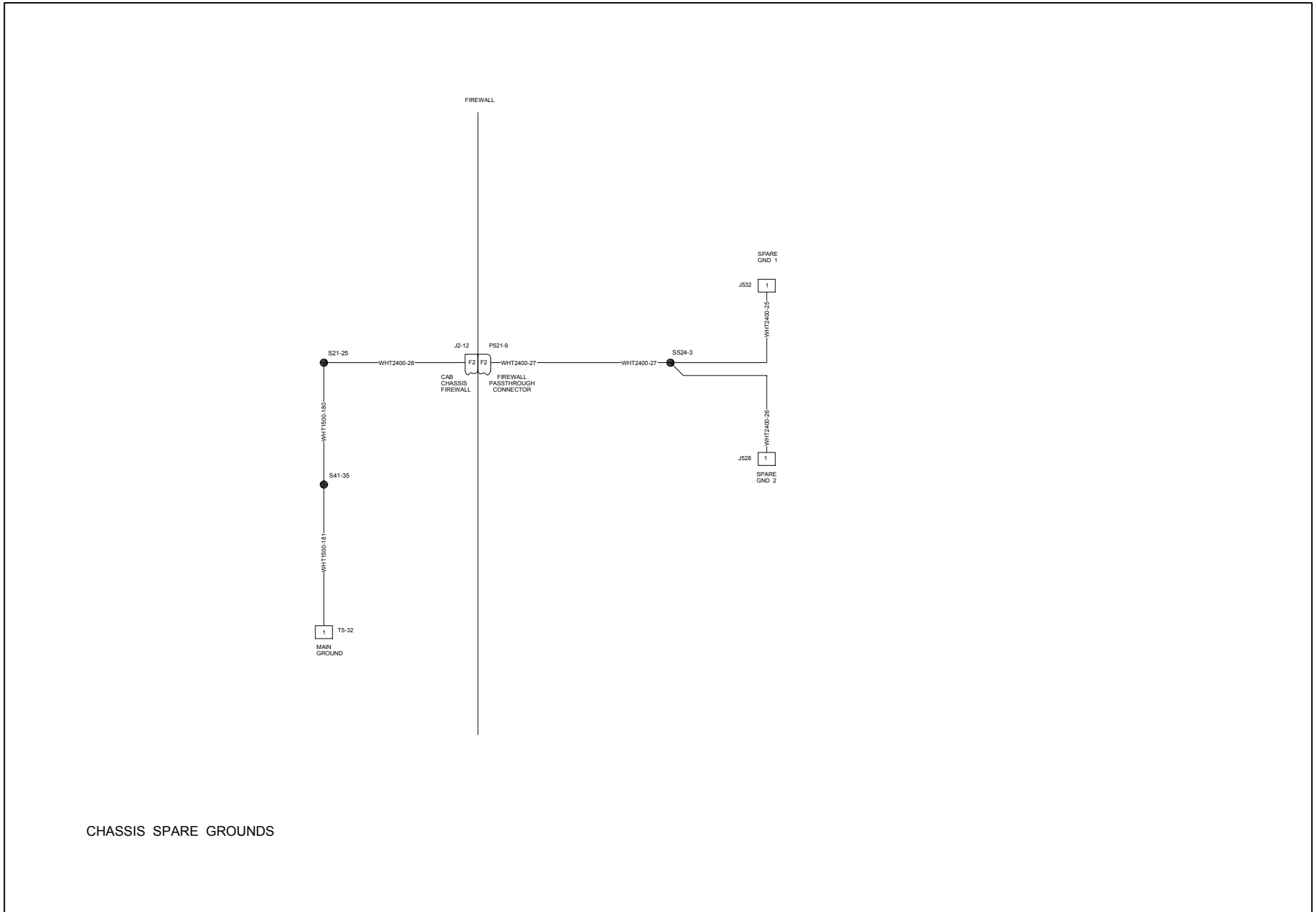

CHASSIS SPARE GROUNDS

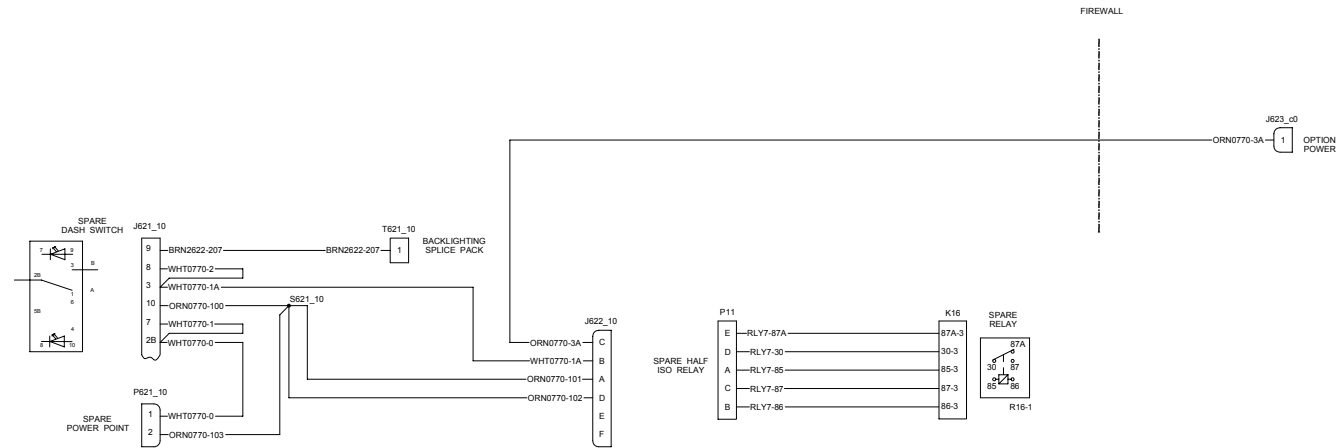

MAIN CAB SPARE RELAY

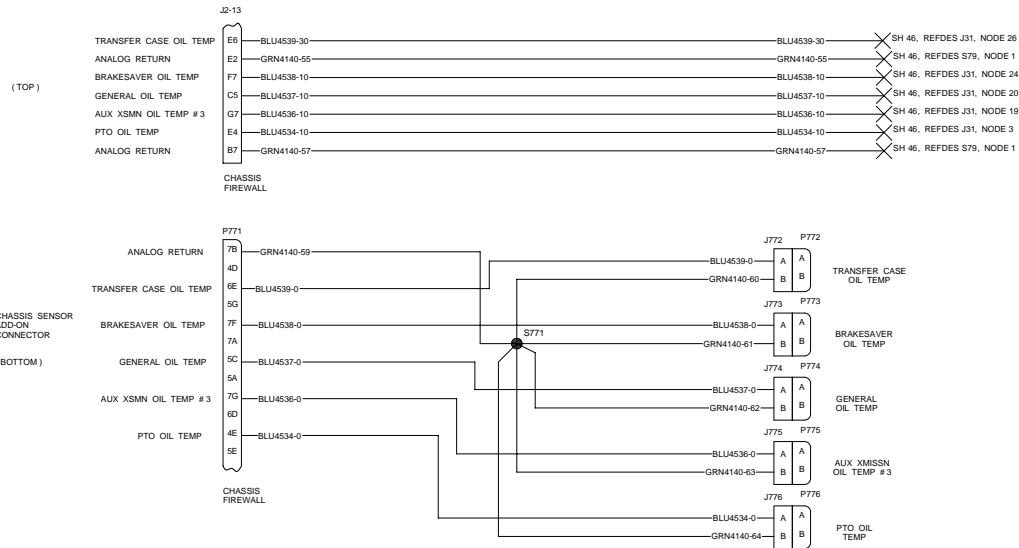

CHASSIS SENSOR ADD-ON - TRANSFER CASE OIL TEMP / BRAKESAVER OIL TEMP
GENERAL OIL TEMP / AUX XSMN OIL TEMP # 3 / PTO OIL TEMP

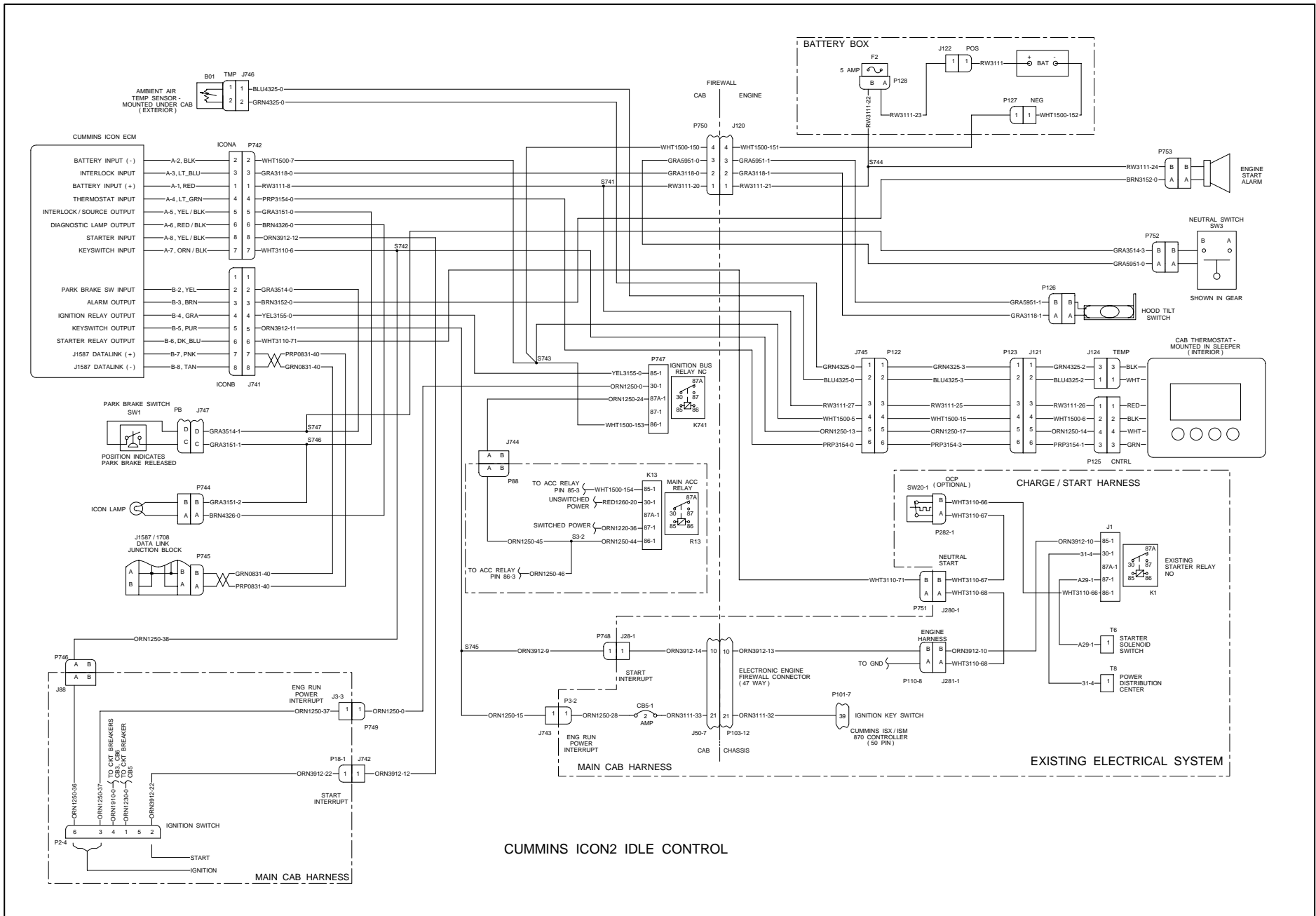

CUMMINS ICON2 IDLE CONTROL

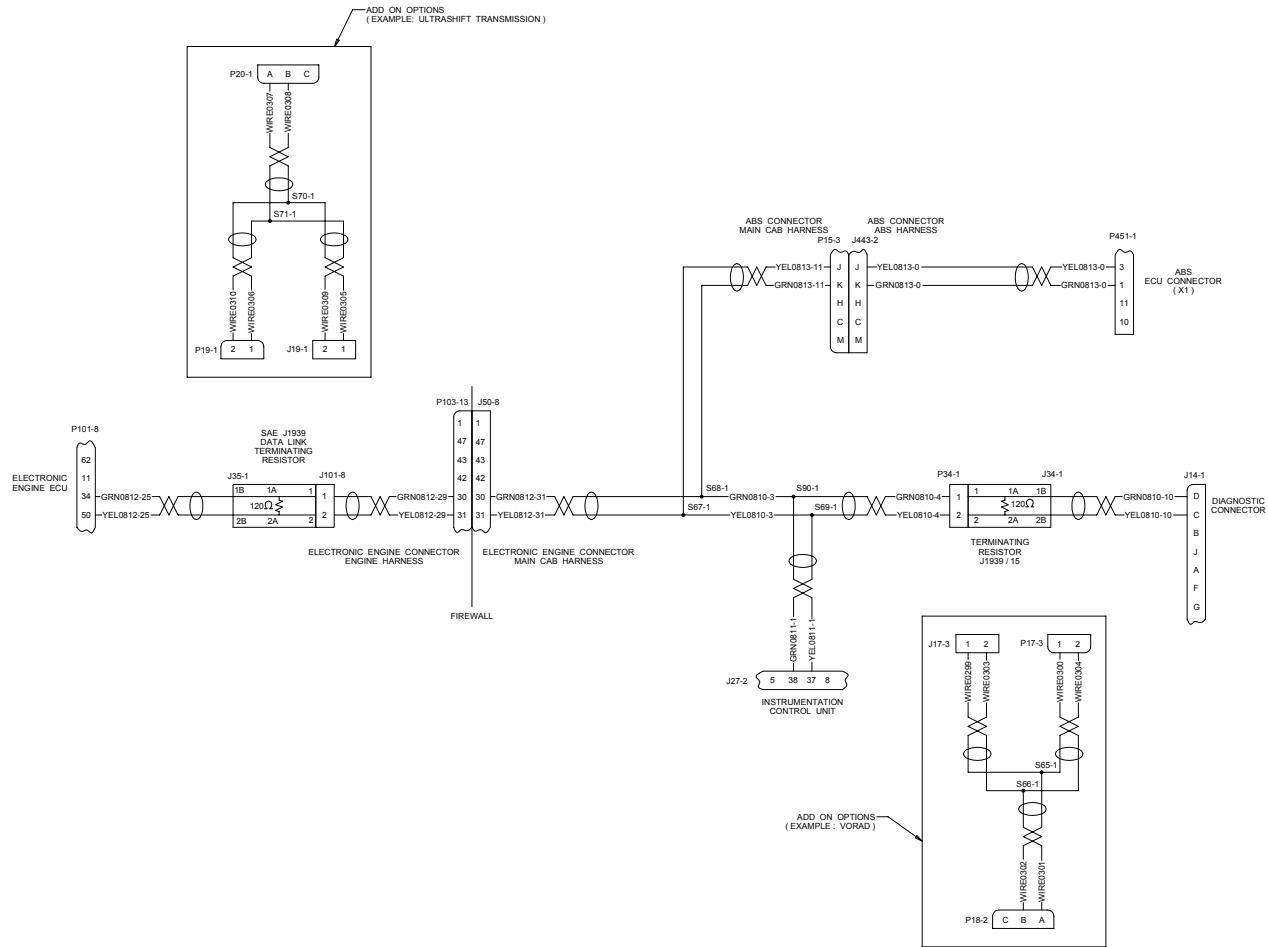

J1939 ARCHITECTURE

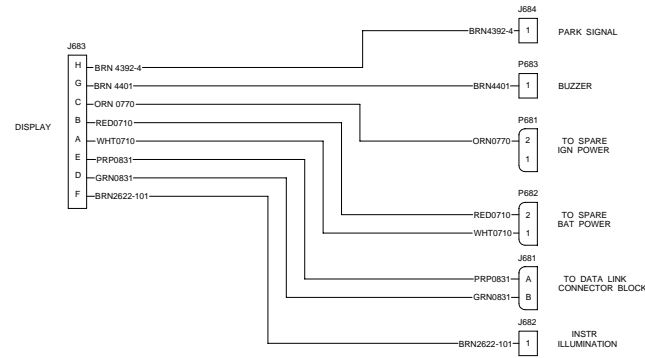

TELEMATICS

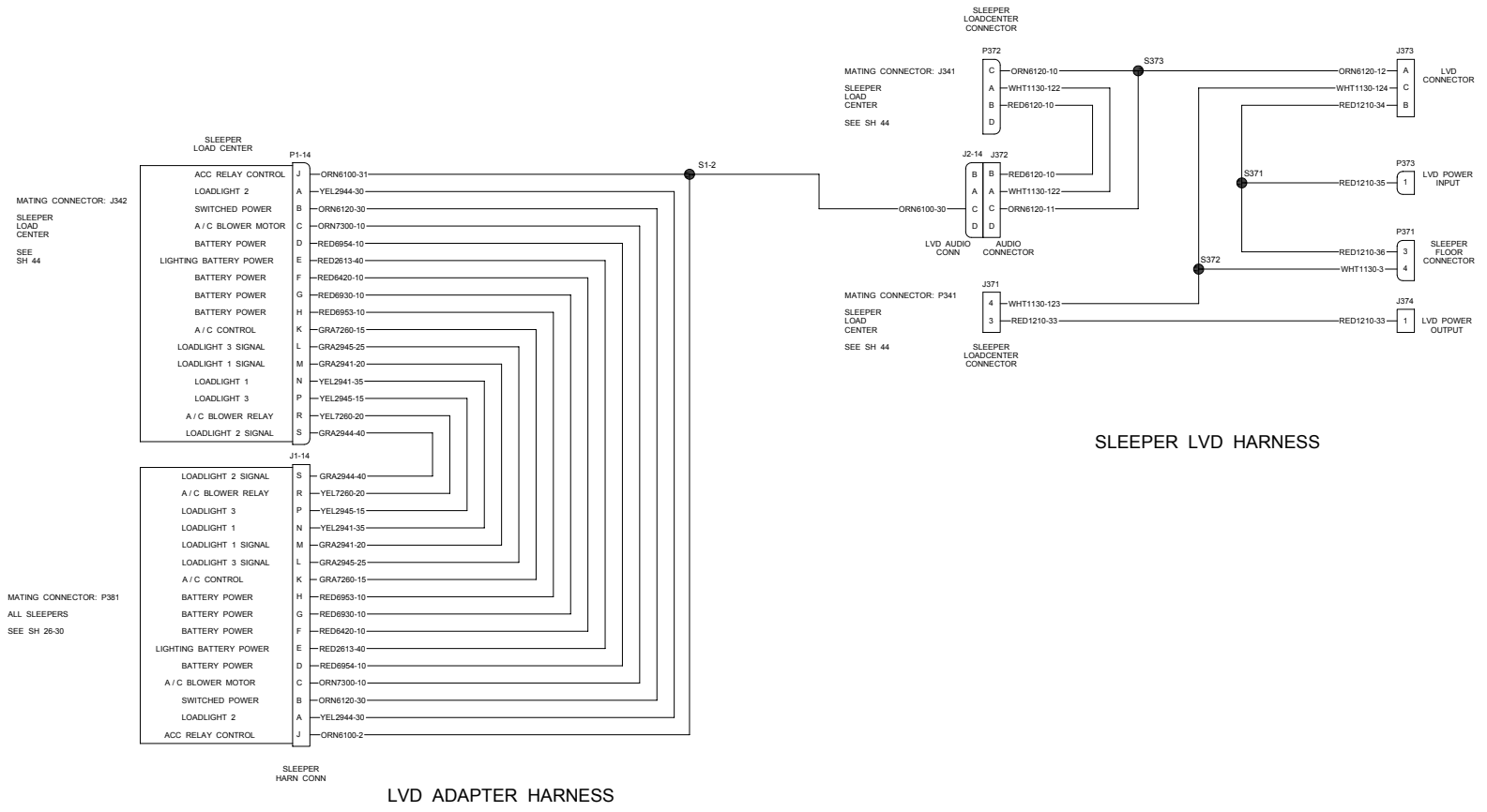

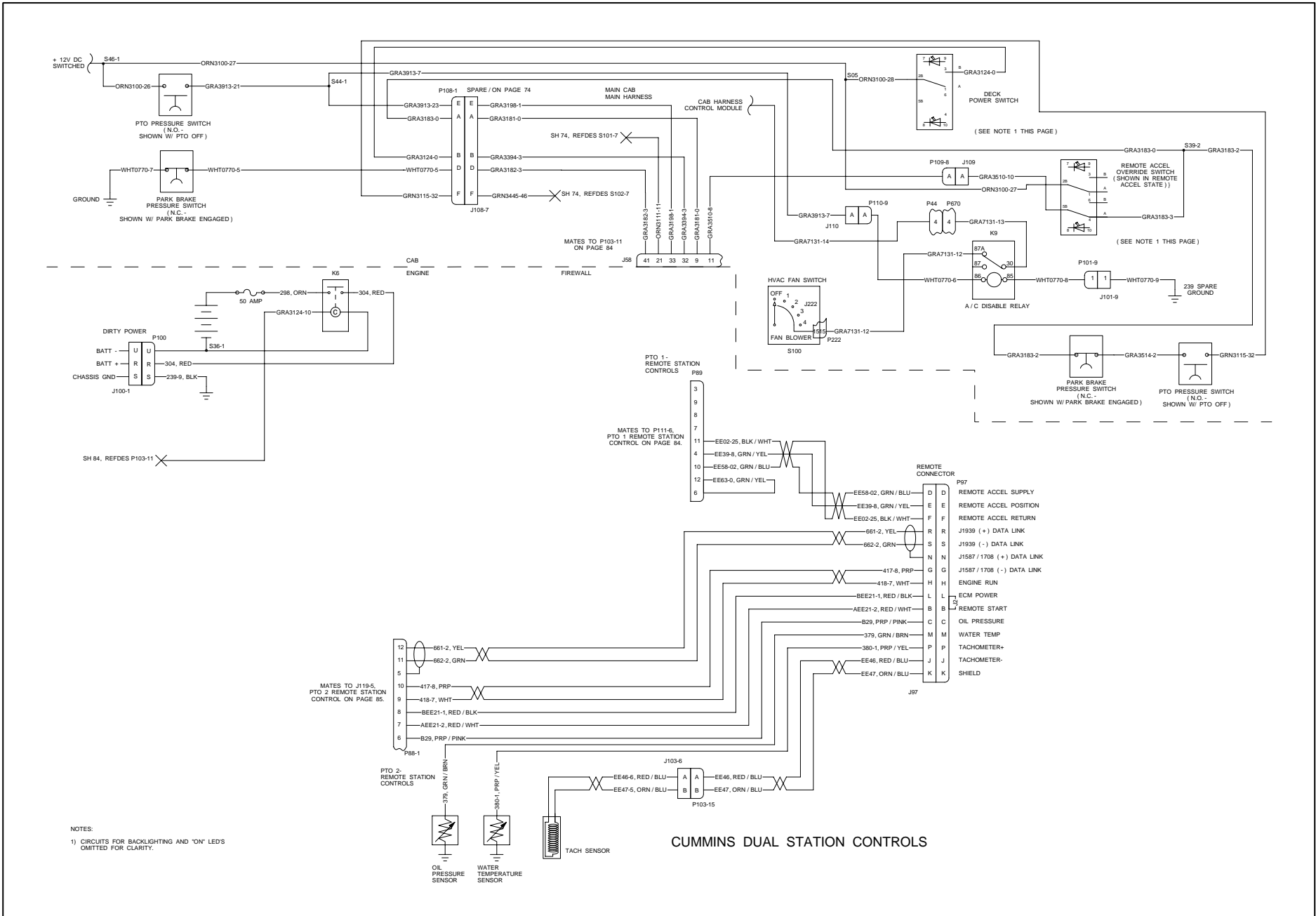

ENGINE BRAKE (AUTO XMSN)

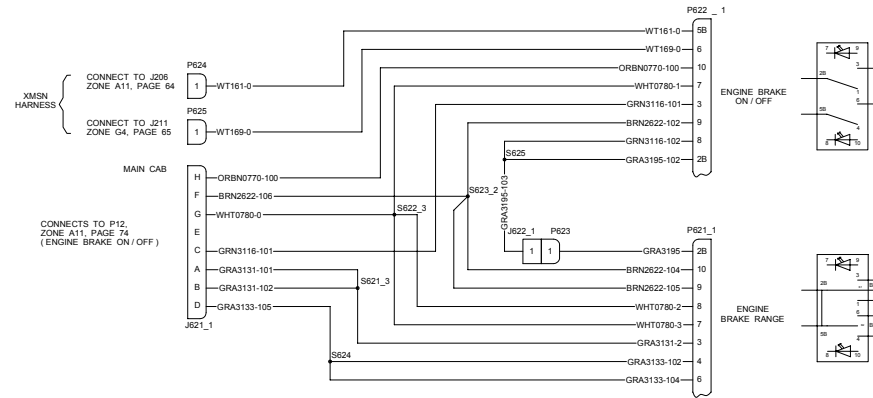

ENGINE BRAKE (MANUAL XMSN)

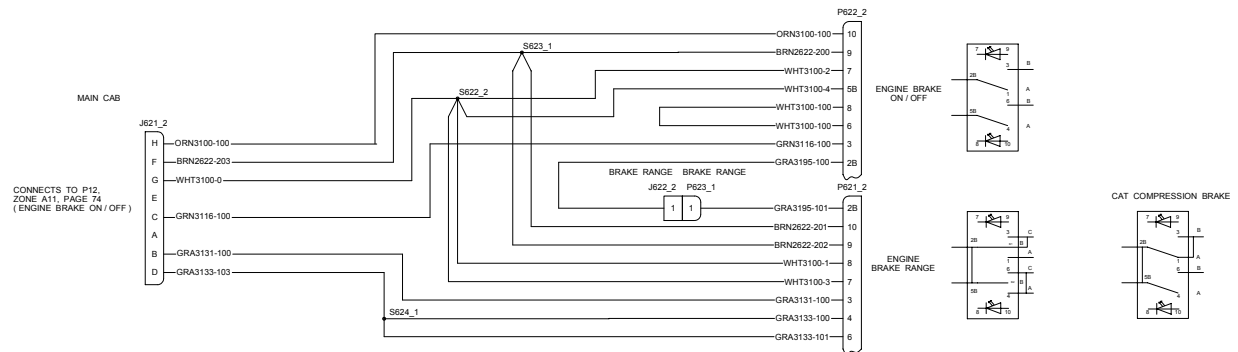

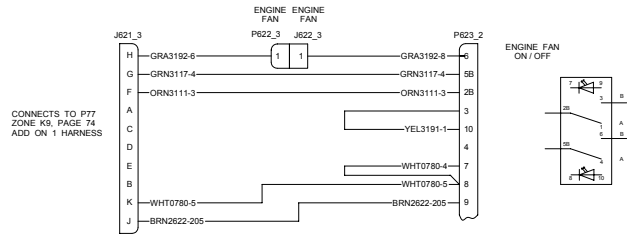

ENGINE FAN (CAT, EXCEPT C9)

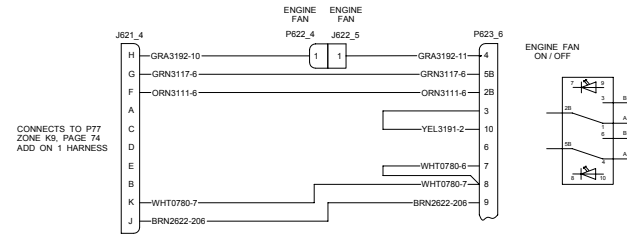

ENGINE FAN (CAT C9)

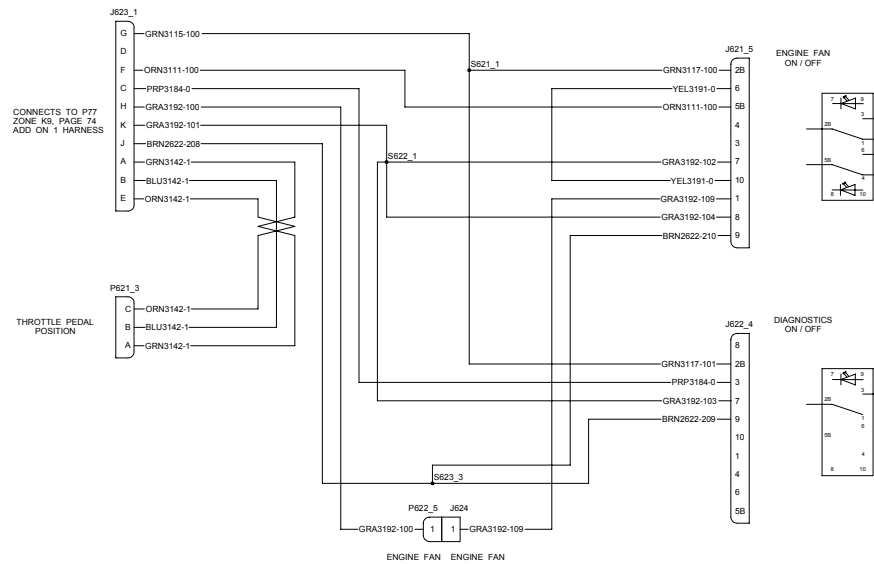

ENGINE FAN (CUMMINS)

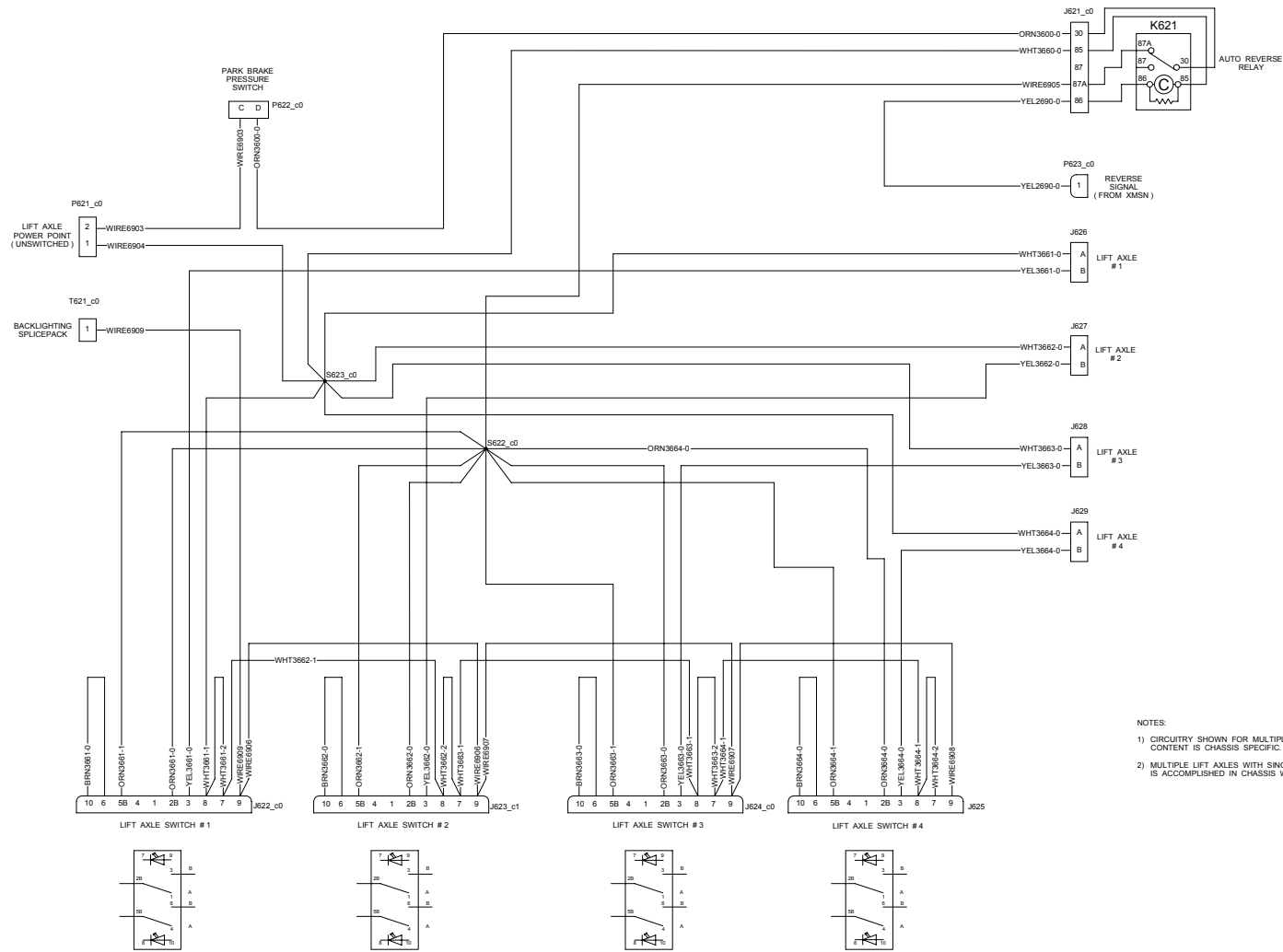

NOTES:
 1) CIRCUITRY SHOWN FOR MULTIPLE LIFT AXLE CONTROL. CONTENT IS CHASSIS SPECIFIC.
 2) MULTIPLE LIFT AXLES WITH SINGLE CONTROL IS ACCOMPLISHED IN CHASSIS WIRING.

LIFT AXLE CONTROL (AXLES W/O AUTO-REVERSE FUNCTIONALITY)

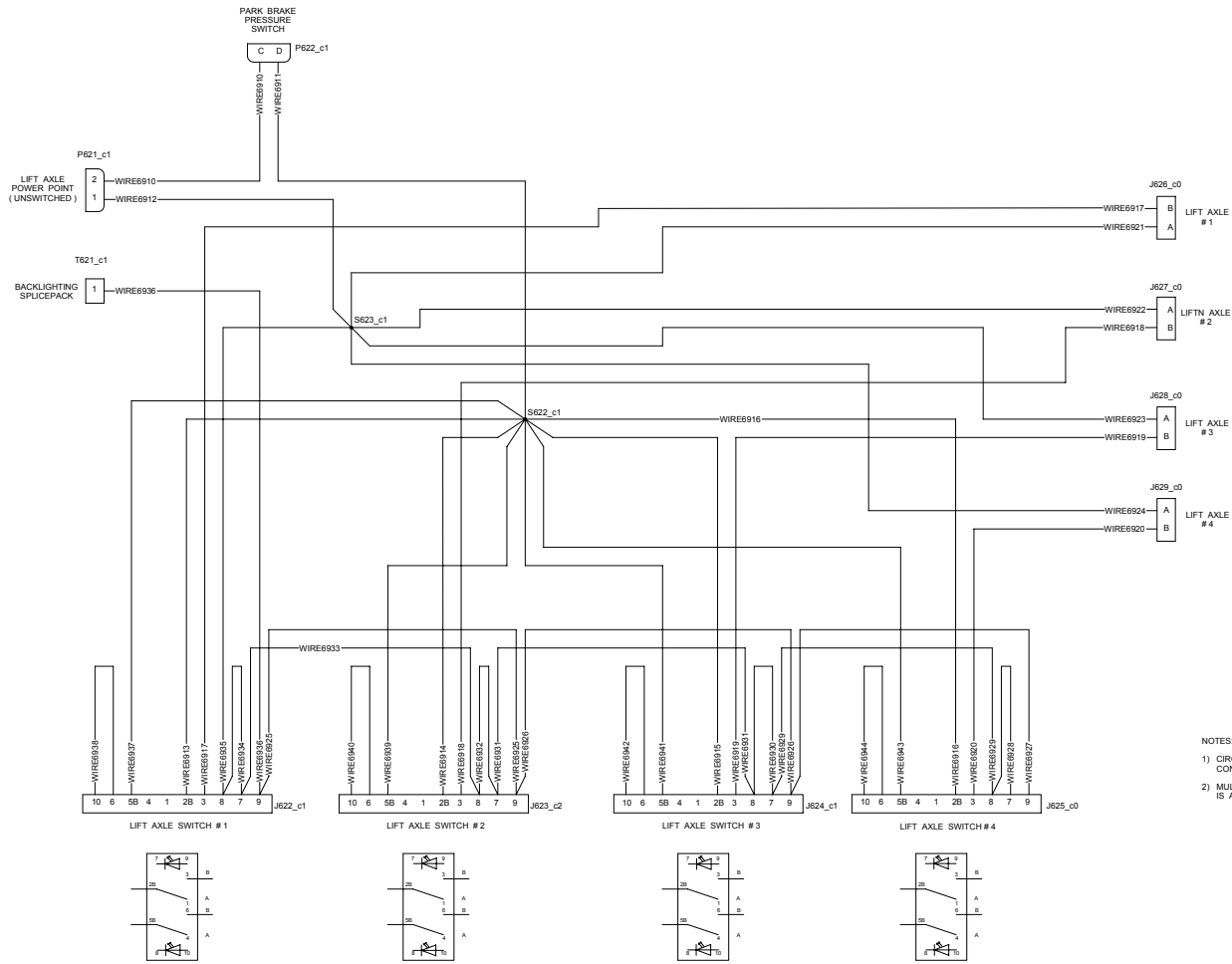

NOTES:
 1) CIRCUITRY SHOWN FOR MULTIPLE LIFT AXLE CONTROL. CONTENT IS CHASSIS SPECIFIC.
 2) MULTIPLE LIFT AXLES WITH SINGLE CONTROL IS ACCOMPLISHED IN CHASSIS WIRING.

LIFT AXLE CONTROL (AXLES W/ AUTO-REVERSE FUNCTIONALITY)

